

.....

SPINEAXIS TRACTION/FLEXION 7-SECTION TABLE

.....

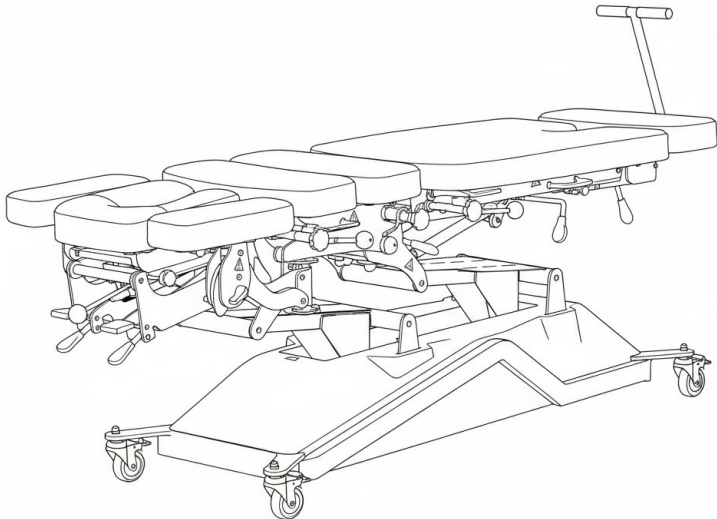

USER GUIDE
SKU: ADI903-40



Thank you for your purchase.



Viva Comfort maintains a strong practice of ongoing development of products and commercial research.



We recognize that starting and maintaining a medical practice is expensive. We'll help make the process cost-effective and elegant. Additionally, our team of specialists will ensure everything you need works as efficiently as possible, so you can effectively treat your clients.

Table of Contents

5 Specifications

6 Safety Warning

6 Risk of Collapse

6 Pinch Risk

6 Infection Risk

7 Risk of Damage to the Table Surface

7 Hardware Accessories Rusting Risk

8 Electrical Hazards

8 Risk of Accidents

8 Other Precautions

9 How To Use

9 Power Connection

9 Height Control Operation

10 Installing the Flexion Handle

11 Mechanical Front Armrest Adjusting

12 Headrest Flip Adjustment

12 Headrest Angle Adjustment

13 Foot Plate Adjusting

14 Body Straps

15 Lateral Flexion

15 Deep Flexion

Table of Contents

How To Use

16 Manual Cervical Traction

16 Lumbar Traction

17 Use of the Drop Function

18 Care & Maintenance Guide

18 Leather Maintenance

18 Maintenance of Metal and Parts

19 Warranty

Specifications

ADI903-40

SpineAxis
Traction/Flexion Table

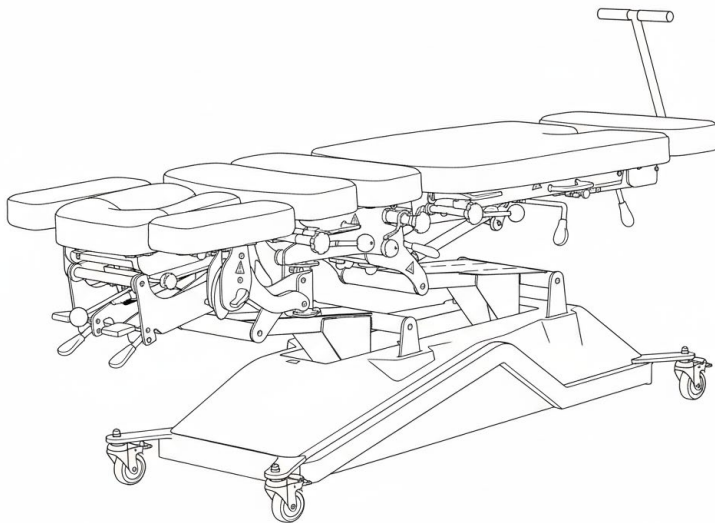

Dimensions: 79" L x 22" W x 21.65" -38.18" H

Weight: 260 lbs.

Lifting Weight Capacity: 440 lbs.

Working Weight Capacity: 600 lbs.

Safety Warning

The user is responsible for preventing damage to this product and injury to patients and/or users.

Risk of Collapse

 If the patient's weight exceeds the working load, the electric chiropractic table may collapse if the patient's weight is not evenly distributed on the table surface.

Pinch Risk

 When the backrest moves down to the end, a hand or finger is placed in the gap between it and the table frame.

 It is strictly forbidden to put your hands into the gap between the middle and rear sections of the table, as this may cause your hands to be pinched when the tailboard moves.

 When executing the drop function, do not extend your hands under the table sections to avoid hand pinching.

 All moving parts may cause injuries to the body or hands, so please do not put your hands into the connecting parts of the equipment.

Infection Risk

When cleaning, please wear gloves, masks, and eye protection to prevent the cleaning spray from rebounding from the contaminated surface.

Risk of Damage to the Table Surface

- The ambient temperature requirement for using and storing the equipment is 0-40 °C. If the equipment is exposed to an environment exceeding the specified temperature for a long time, the leather surface may crack or peel.
- The humidity requirement for the equipment's transportation, use, and storage is 20%~80%. The leather surface may crack or peel if the equipment is exposed to an overly dry or humid environment for a long time.
- The leather of the equipment table is strictly prohibited from contacting acidic and alkaline substances. Scrubbing the table with a non-neutral detergent may cause the leather to crack and peel prematurely, reducing its service life.
- The leather of the table is strictly prohibited from contacting liquid water. Liquid water may penetrate the leather, causing the sponge inside the leather to degenerate, affect use, or crack and peel.

Hardware Accessories Rusting Risk

- The humidity requirement for equipment transportation, use, and storage environment is 20%~80%. If the equipment is exposed to an overly humid environment for a long time, the hardware accessories may rust.
- The metal parts of the equipment are strictly prohibited from contacting acidic substances; otherwise, they may cause damage to the paint surface and then rust.
- The metal parts of the equipment are strictly prohibited from contacting liquid water, which may cause metal materials to rust.

Electrical Hazards

- If the power cord is damaged, please replace it in time. If not replaced in time, there is a risk of electric shock.
- Do not use the device on wet floors or humid environments. The ambient temperature should be kept between 0°C-40°C.
- Do not use the device in an environment where flammable or explosive gases or vapors.

Risk of Accidents

- Under no circumstances should any object or body be placed in the structure below the table to avoid damaging objects or causing casualties when the equipment is lifted or collapsed unexpectedly.
- Do not stand on the device to avoid falling or rollover.

Other Precautions

- It is strictly prohibited to approach fire sources.
- Do not place it in direct sunlight.
- Do not place it in high-temperature places such as heaters.

How To Use

Power Connection

- A.** Remove the table from the packaging and position it on a flat surface.
- B.** Connect the table's power cord plug to the socket outlet.
- C.** Before each use, turn the safety lock key to the "Open" to enable power connection.

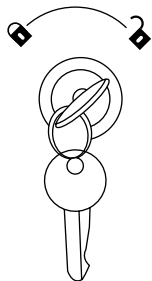

Reminder:

- 1.** The safety lock should only be installed by the original factory. Users are prohibited from installing it without permission.
- 2.** Please disconnect the power supply and remove the key when the designated doctor or operator leaves.

Height Control Operation

A. Foot Pedal Control

- a.** Operate the foot control to raise or lower the table height, as shown.

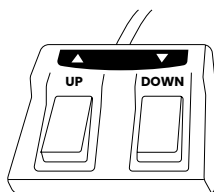

B. Hand Control

- a.** Operate the hand control to raise or lower the table height.

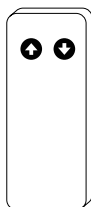

Installing the Flexion Handle

- A.** Fully insert the fixing block at the base of the flexion handle into the groove at the bottom of the foot plate, and then rotate the fixing knob accordingly to lock the flexion handle.
- B.** Reverse operation to remove the handle.

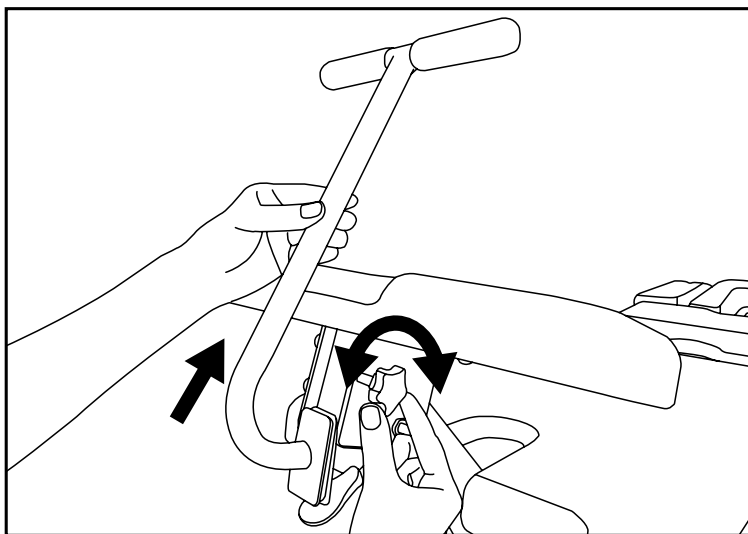

Mechanical Front Armrest Adjusting

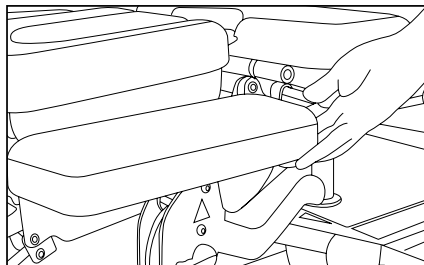

Lift the armrests up to the desired height, as shown.

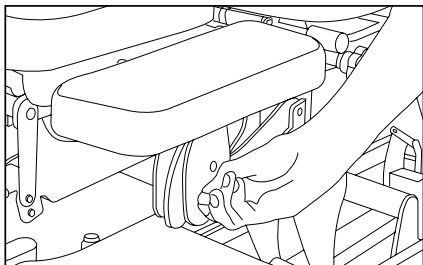

Lower the armrests by rotating the trigger on the side of the cradle upward.

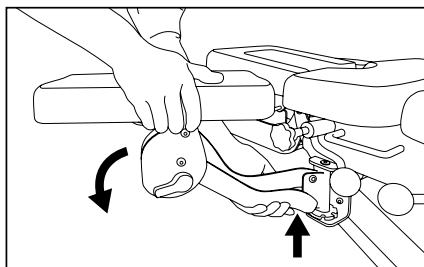

Lifting the base of the armrest and rotating it can achieve the rotation of the armrest.

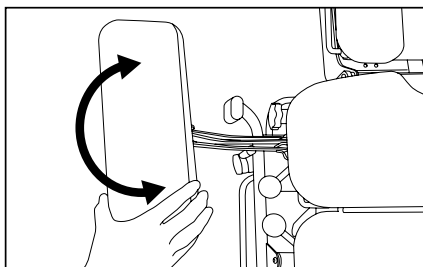

Gently rotating the armrest cushion can also achieve the angle rotation of the armrest cushion.

Headrest Flip Adjustment

- A.** Press upward the pneumatic control switch located on the front right side of the headrest, and the pneumatic rod will automatically push the headrest to flip forward.
- B.** Use your other hand to control the angle of the headrest to the appropriate position, then release the pneumatic control switch and the headrest angle will be fixed.

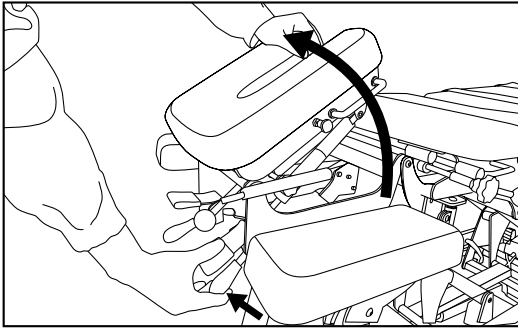

Headrest Angle Adjustment

- A.** Press upward the pneumatic control switch located on the left side in front of the headrest, and the pneumatic rod will automatically push the headrest to rotate along the root.
- B.** After controlling the angle of the headrest to the appropriate position with your other hand, release the pneumatic control valve and the headrest angle will be fixed.

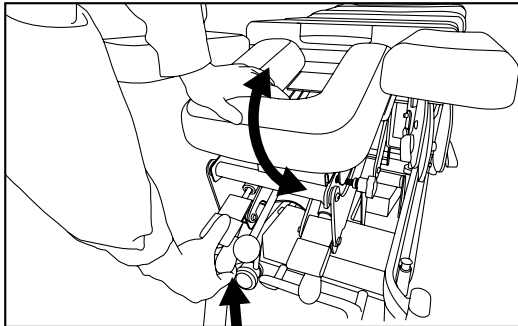

Foot Plate Adjusting

A. Push the gas spring switch under the foot plate forward, rotate the foot plate to a suitable position, and then release the gas spring switch.

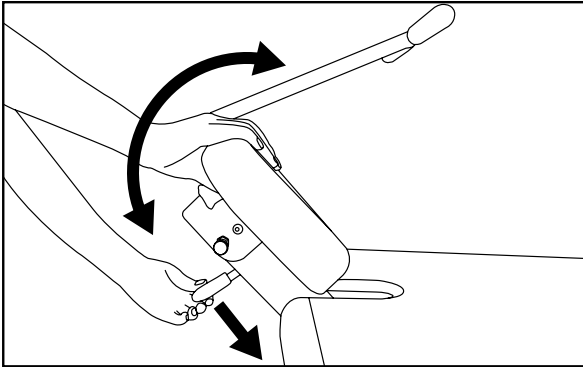

B. Pull out the pin of the bracket under the footboard, rotate the footboard to a suitable angle, and then reinsert the pin to lock the angle of the footboard.

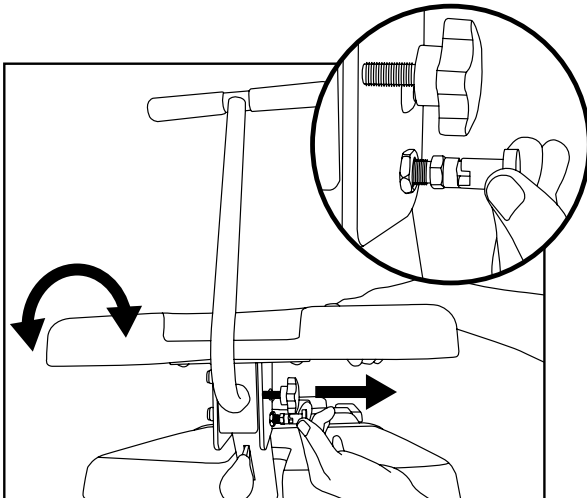

C. The foot plate is suitable for providing support for the patient's lower leg and foot during lumbar spine treatment.

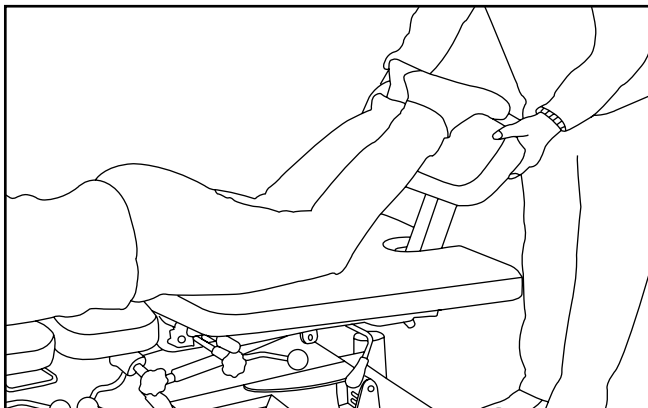

Body Straps

Our Electric Chiropractic Table is equipped with two body straps, which can fix the patient's pelvis or upper limbs on the table surface through the U-shaped fixings on both sides of the table frame.

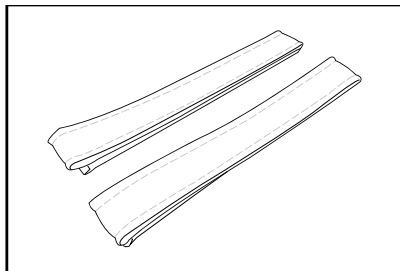
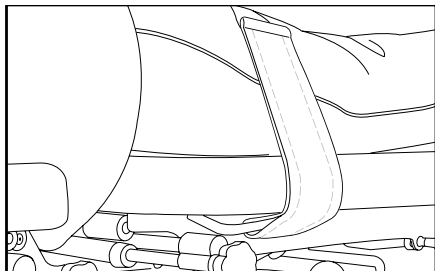

Lateral Flexion

Pull the locking handle of the lateral flexion upwards to allow the tail board to swing horizontally. When it swings to a suitable position, press the locking handle downwards to fix the position of the tail board. A professional chiropractor can also reposition and exercise the patient's lumbar spine through the free swinging function of the tail plate as shown.

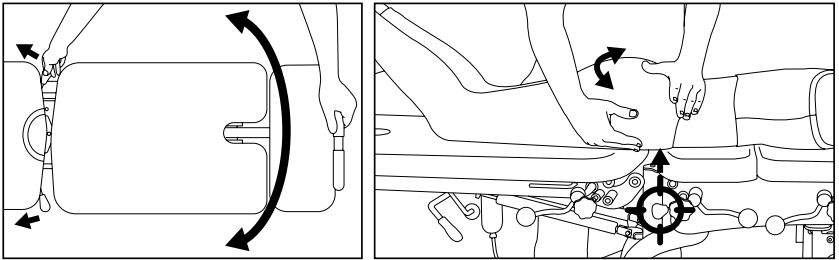

Deep Flexion

Push the flexion pneumatic control switch upwards and use the flexion control handle to achieve the deep flexion of the tail plate as shown. When it is necessary to fix it at any position, push the flexion pneumatic control switch downwards to achieve position locking.

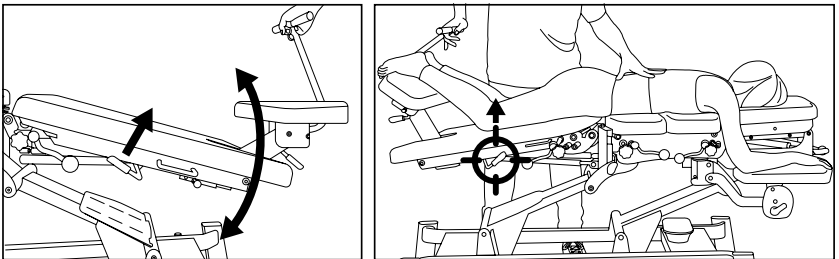

Manual Cervical Traction

Pull out the latch on the right side of the headrest and rotate the latch to the left or right to put it in the pulled-out state. As shown, traction is performed on the patient's cervical spine. When not performing cervical traction, reposition the headrest and rotate the latch so that it is inserted to lock the headrest.

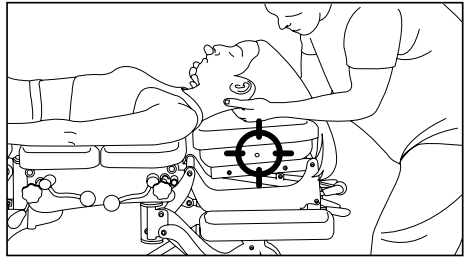
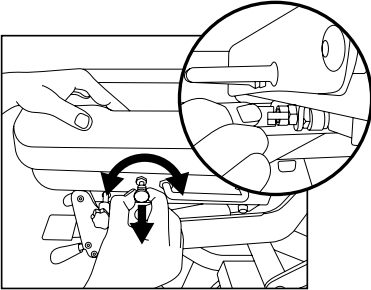

Lumbar Traction

Pull out the latch on the right side of the tail board and rotate the latch to the left or right to put it in the pulled-out state. As shown in, traction is performed on the patient's lumbar spine. When not performing lumbar traction, reposition the tail board and rotate the latch so that it is inserted to lock the headrest.

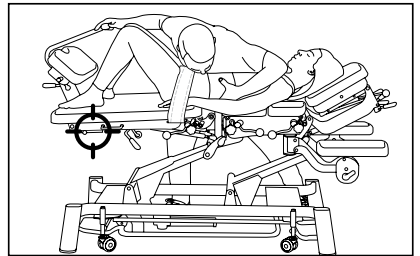
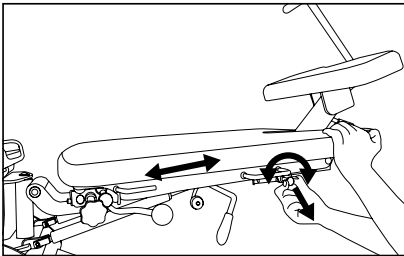

Use of the Drop Function

A. Turn the drop-control-ball-handle in the direction as shown to lift up each section of the table surface.

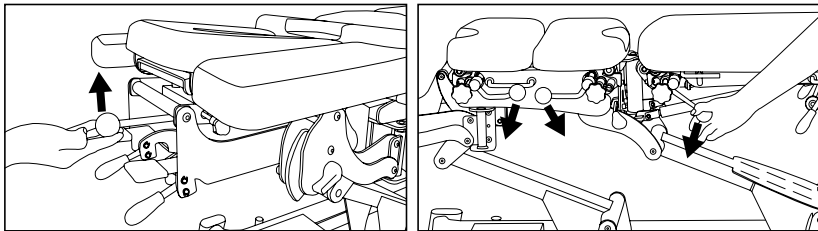

B. Rotate the knob under each section of the table surface to adjust the drop resistance.

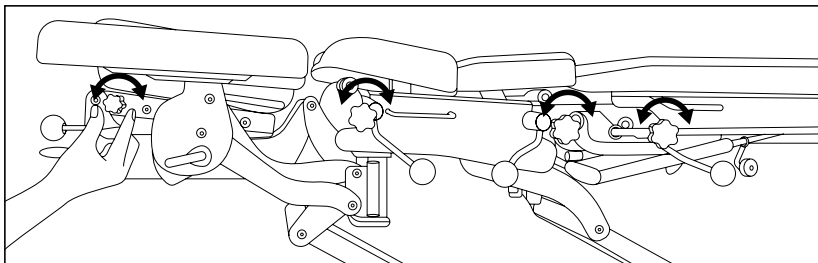

C. Perform drop treatment on various parts of the patient.

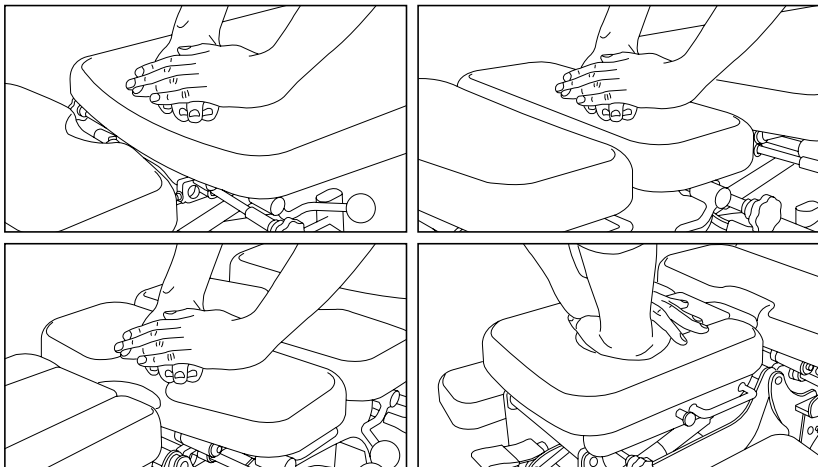

Care & Maintenance Guide

Leather Maintenance

- a.** It is recommended to use a small amount of neutral detergent cleaner or wipe with a dry towel when wiping the leather, then wipe it clean with a dry cloth, dry it, and place it in a ventilated place to dry.
- b.** If disinfection is necessary, it is acceptable to use hypochlorous acid disinfectant or alcohol below 70% concentration to wipe it. It is prohibited to use BA-SI disinfectant or other highly corrosive disinfectants for disinfection; otherwise, they may accelerate the aging of the leather, causing the leather to change color, deform, harden, become brittle, or even peel off the surface.
- c.** When not used for a long time, it is recommended that the table be covered with a table cover and stored in a dry environment. Avoid direct sunlight, rain, humidity, and other environments.
- d.** Too high or too low-temperature environments may accelerate the aging of leather.
- e.** Sharp objects are prohibited from touching the leather surface.

Maintenance of Metal and Parts

- a.** A dry towel is recommended to wipe metal.
- b.** If disinfection is necessary, it is acceptable to use hypochlorous acid disinfectant or alcohol with a concentration below 70% to the maximum extent possible. Using BA-SI disinfectant or other highly corrosive disinfectants is prohibited for disinfection. Otherwise, the paint or wood veneer may be damaged.

Warranty

1. Viva Comfort (the "Company" or "Tiger Companies") warrants to the purchaser that the product will be free from defects in workmanship and materials for a period of 1 year from the date of purchase. The warranty period is not extended if we repair, replace, exchange, or provide a refund for the product (as determined in our sole discretion). We may change the availability of this limited warranty at our discretion, but any changes will not be retroactive.
2. These warranties are not assignable or transferable to any other person, including, without limitation, any subsequent owner or other transferee of the product.
3. This Warranty does not apply to: (a) damage caused by misuse, tampering, abuse, neglect, or accident; (b) damage caused by improper installation, modification, or service; (c) alteration of the serial number; or (d) use that violates the instructions furnished by the Company will void this warranty.
4. The sole responsibility of the Company shall be limited to (a) the repair or replacement (in its sole discretion) of any component of the product which fails to conform to this; (b) a refund the purchase price of such product (in its sole discretion), at no cost to the purchaser for the period of the warranty, or (c) an exchange for a similar product, comparable in function and price.
5. Contact the Company directly at 1-(800)-805-1790 to obtain service under this warranty. If it becomes applicable to send a defective product to the Company, a Return Authorization Number must first be obtained from the Company. In order to obtain service under this warranty, purchaser may be required to provide the Company with the following items (a) proof of purchase, (b) photographs and or videos (of the damage, and (c) a written testimonial describing the defect.
6. Products shipped without prior Return Authorization and Return Authorization Number may not be accepted, and the Company will not be responsible for their disposition and/or cost of return to the owner.
7. The Company will not assume any responsibility for any loss or damage incurred in shipping and or delivery.
8. The product(s) must be returned within 14 calendar days of receiving the return authorization from the Company and must include the original proof of purchase for the warranty to be honored.
9. Any implied warranties that the purchaser may have are limited to the duration of the warranties described above. There are no further warranties that extend or apply beyond the face hereof, and the Company expressly disclaims and excludes any and all warranties of merchantability or fitness for a particular purpose. Some states do not allow limitations on how long an implied warranty lasts, so the above limitation may not apply to you.
10. THE REMEDIES DESCRIBED ABOVE ARE YOUR SOLE AND EXCLUSIVE REMEDIES AND THE COMPANY'S ENTIRE LIABILITY FOR ANY BREACH OF THIS LIMITED WARRANTY. OUR LIABILITY SHALL UNDER NO CIRCUMSTANCES EXCEED THE ACTUAL AMOUNT PAID BY YOU FOR THE DEFECTIVE PRODUCT, NOR SHALL WE UNDER ANY CIRCUMSTANCES BE LIABLE FOR ANY CONSEQUENTIAL, INCIDENTAL, SPECIAL OR PUNITIVE DAMAGES OR LOSSES, WHETHER DIRECT OR INDIRECT. SOME STATES DO NOT ALLOW THE EXCLUSION OR LIMITATIONS OF INCIDENTAL OR CONSEQUENTIAL DAMAGES, SO THE LIMITATION MAY NOT APPLY TO YOU.
11. This warranty gives you specific legal rights, and you may also have additional rights which vary from state to state.

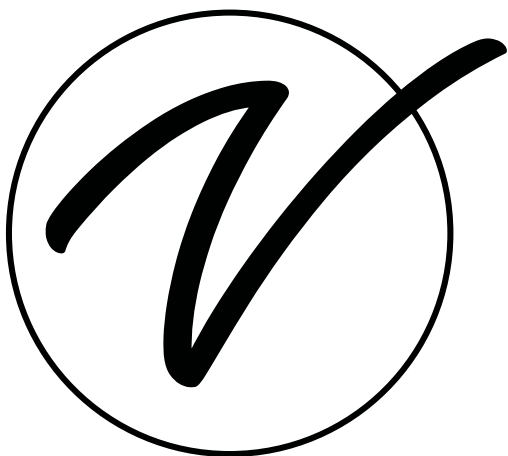

ADI903-40

© 2025 Viva Comfort
vivacomfort.com