

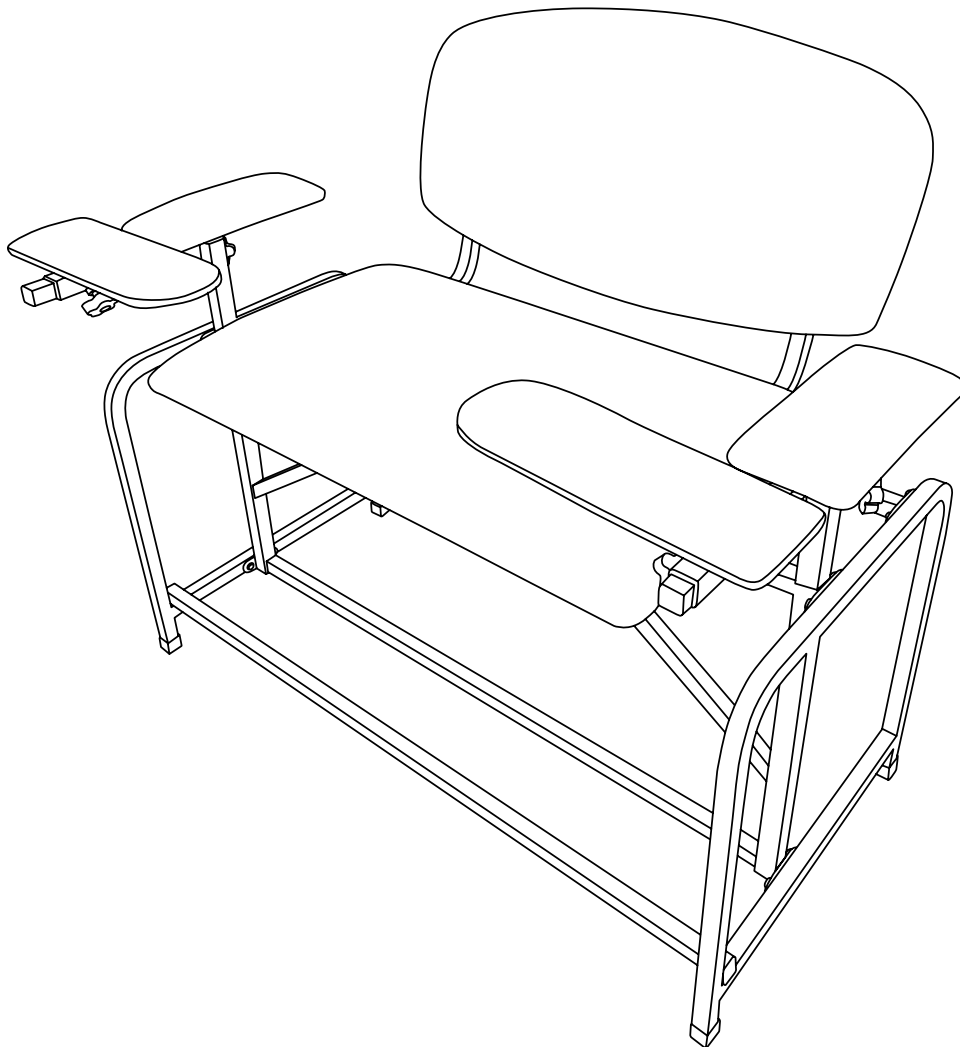

.....

Bariatric Extra-Tall Padded
Blood Drawing Chair

.....



USER GUIDE

ADI997-01-BT-SERIES



Thank you for your purchase.



Viva Comfort maintains a strong practice of ongoing development of products and commercial research.



We recognize that starting and maintaining a medical practice is expensive. We'll help make the process cost-effective and elegant. Additionally, our team of specialists will ensure everything you need works as efficiently as possible, so you can effectively treat your clients.

Table of Contents

2	Parts List
3	Hardware List
3	Tool Needed
4	Assembly Instructions
11	Care & Maintenance Guide
15	Warranty

Parts List

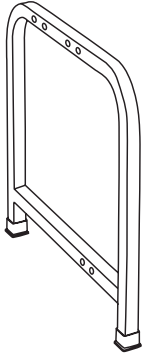
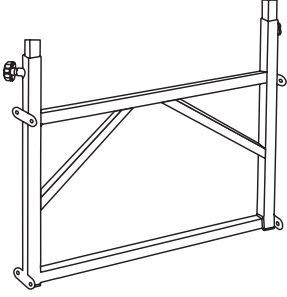
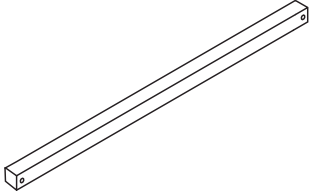
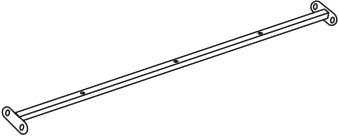
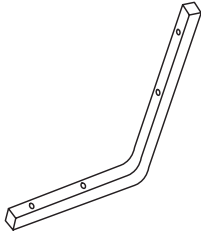
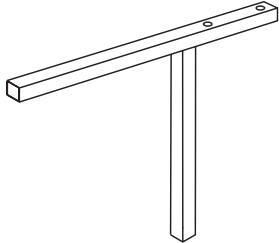
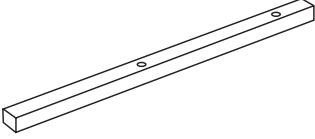
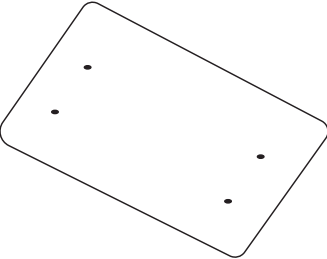
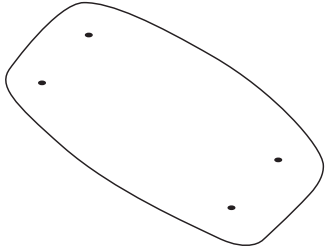
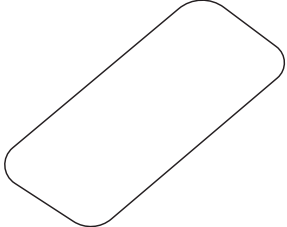
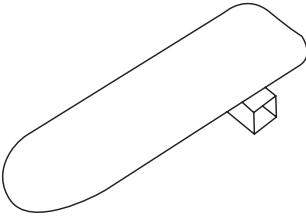
<p>A</p>  <p>Leg (x2)</p>	<p>B</p>  <p>Center H Support</p>	<p>C</p>  <p>Footrest</p>
<p>D</p>  <p>Seat Support</p>	<p>E</p>  <p>Backing Rails (x2)</p>	<p>F</p>  <p>Armrest Frame (x2)</p>
<p>G</p>  <p>Seat Support Bar</p>	<p>H</p>  <p>Seat Cushion</p>	<p>I</p>  <p>Backrest Cushion</p>
<p>J</p>  <p>Armrest Cushion (x2)</p>	<p>K</p>  <p>Front Flip Armrest (x2)</p>	

Hardware List

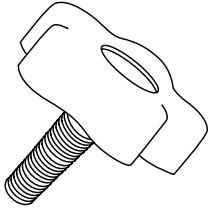
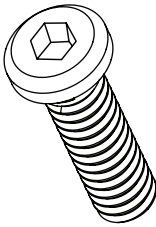
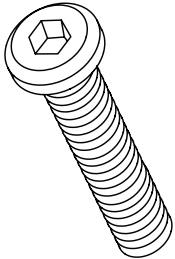
<p>1</p>  <p>Adjustment Knob (x4)</p>	<p>2</p>  <p>Screw 1 (M8x20mm) (x12)</p>	<p>3</p>  <p>Screw 2 (M8x40mm)(x20)</p>
---	--	---

Tool Needed

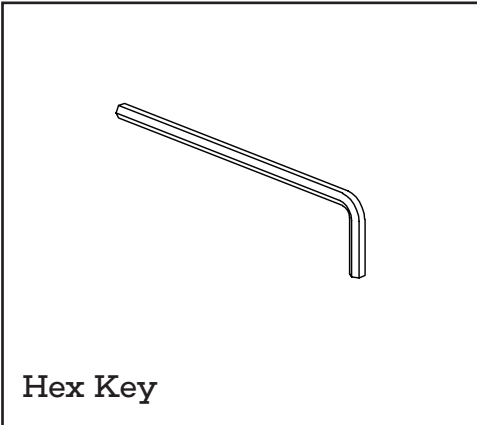

Assembly Instructions

Specifications:

Weight Capacity: 750 lb.

Weight: 70.93

Dimensions: 42.13" x 48.43" x 32.28"

Note:

When Assembling the chair, do not over-tighten the screws. Finish the whole assembly and then tighten firmly.

Step 1:

A. Locate both Legs (A) to the Center H Support (B).

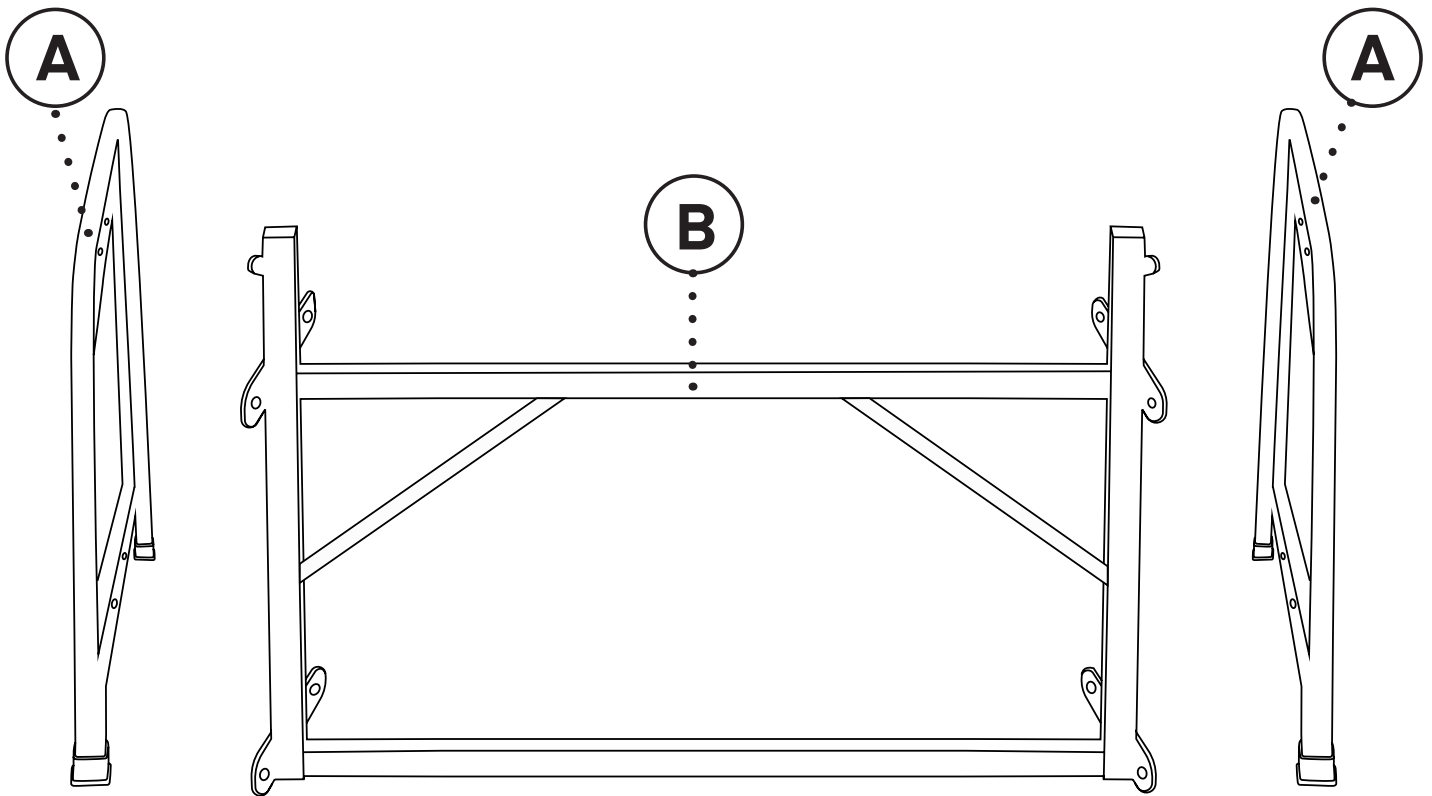

Step 2:

A. Attach both Legs (A) to the Center H Support (B) using eight Screw 1's (2).

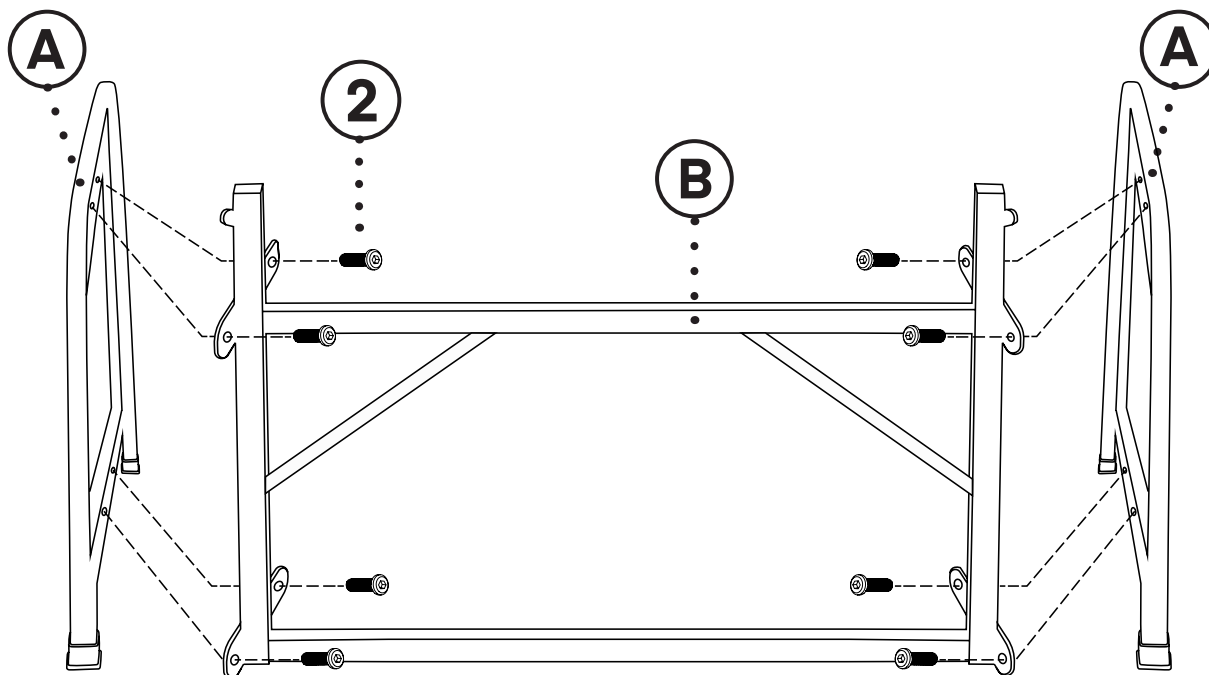

Step 3:

A. Insert two Adjustment Knob's (1) into the left and right pole, as pictured.

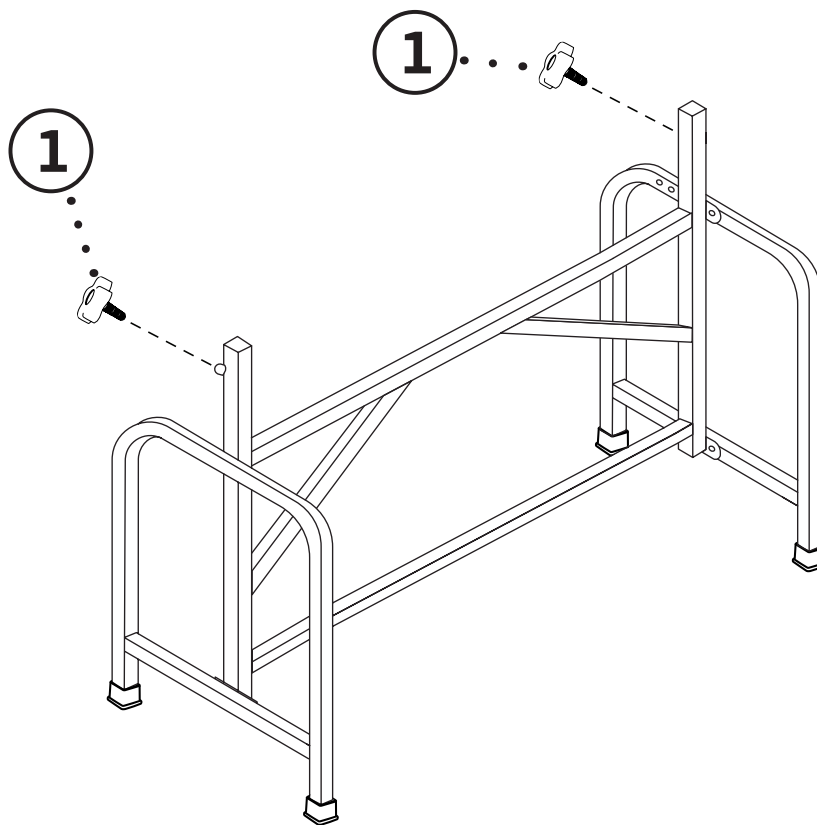

Step 4:

A. Locate the Footrest (C), and place it between both Legs (A), as pictured.

B. Secure it into place with two Screw 2's (3).

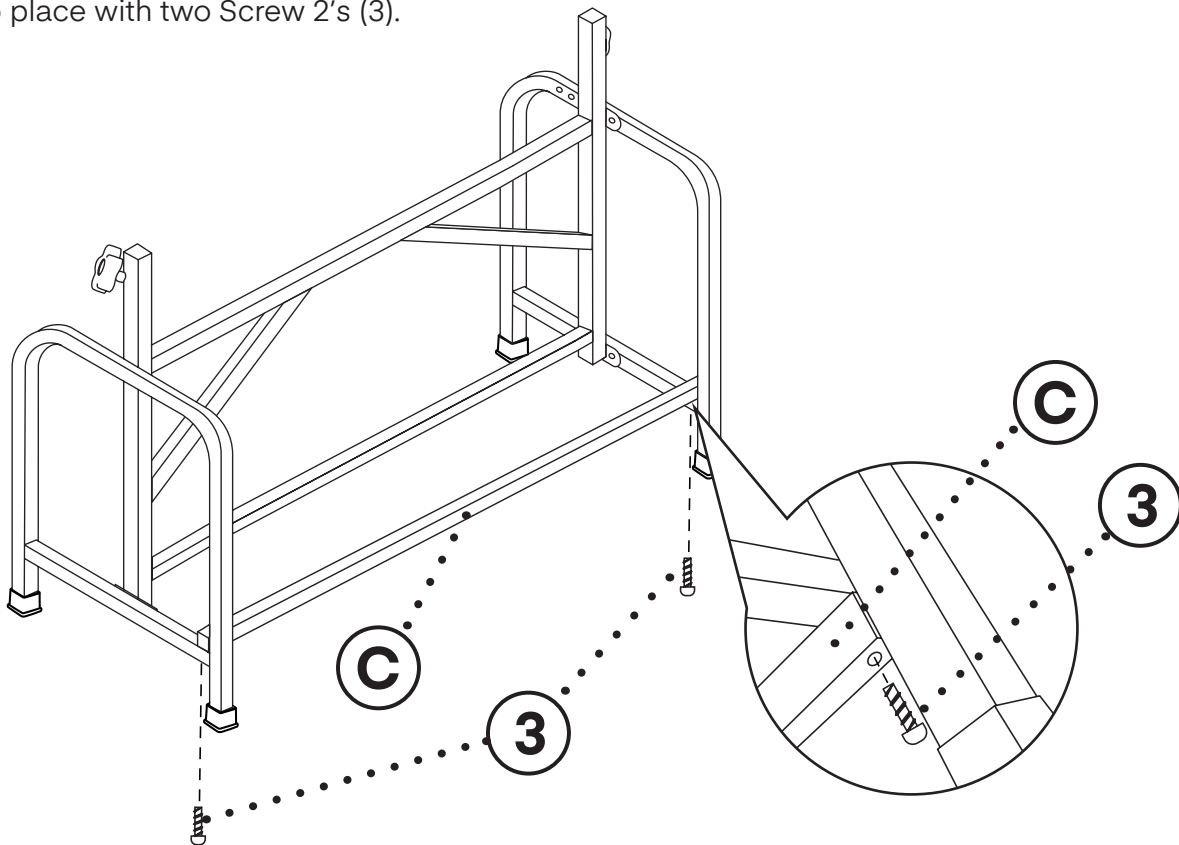

Step 5:

A. Locate and place the Seat Support (D) between both Legs (A), as pictured.

B. Secure into place with four Screw 1's (2).

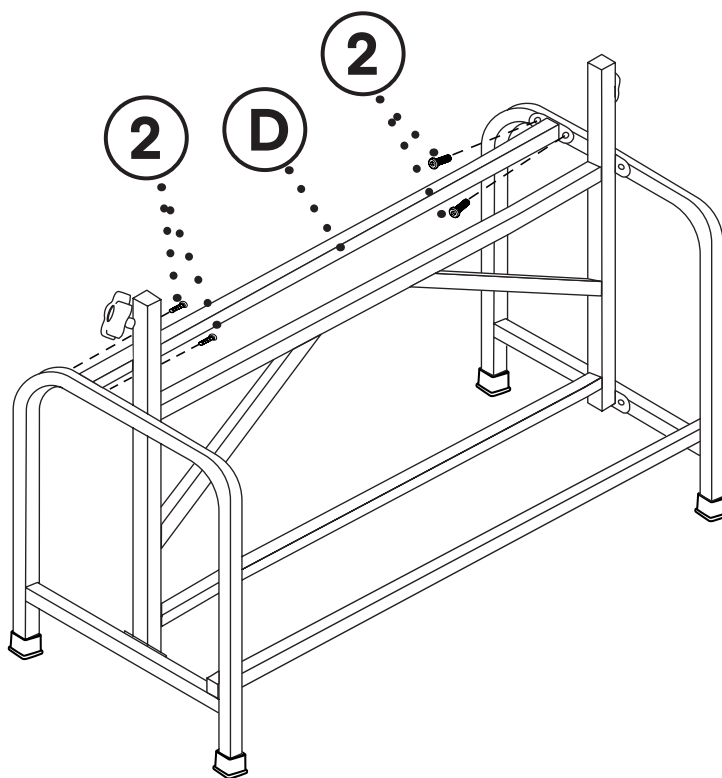

Step 6:

A. Locate the Seat Support Bar (G), line it up with the holes on the assembled base.

B. Secure the the Seat Support Bar (G) with two Screw 2's (3) through the Center H Support (B) and Seat Support (D).

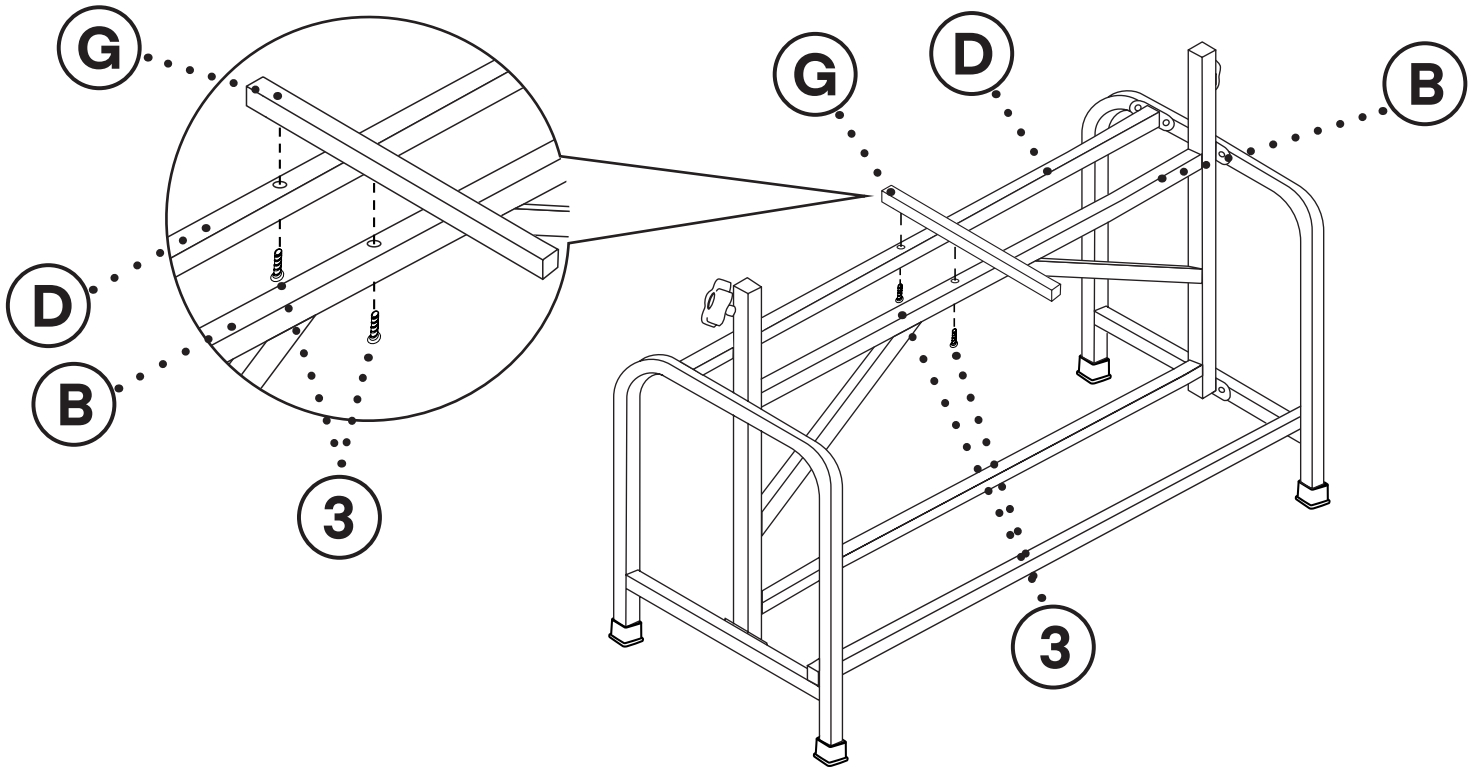

Step 7:

A. Locate both Backing Rails (E) and the Seat Cushion (H).

B. Attach both Backing Rails (E) to the Seat Cushion (H) with four Screw 2's (3).

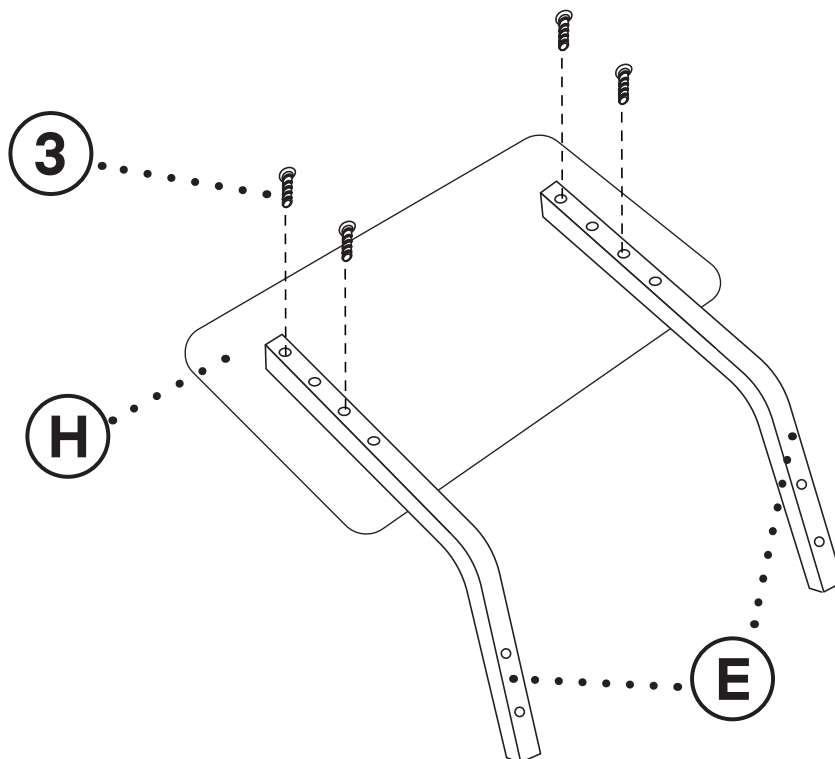

Step 8:

A. Locate and attach the Backrest Cushion (I) with four Screw 2's (3), as pictured.

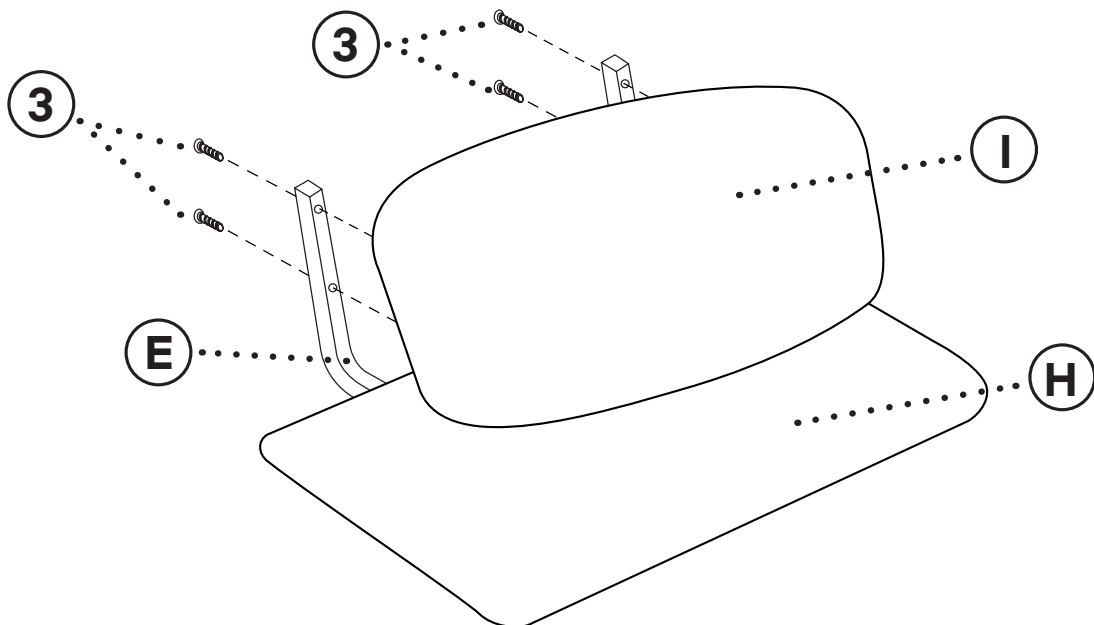

Step 9:

A. Locate the Seat Support (D) and Center H Support (B), line it up with the holes on the bottom of the assembled chair.

B. Attach the constructed seat to the assembled base, as pictured.

C. Insert four Screw 2's (3) through the Center H Support (B) and Seat Support (D) and into the seat.

D. Tighten the screws until secure.

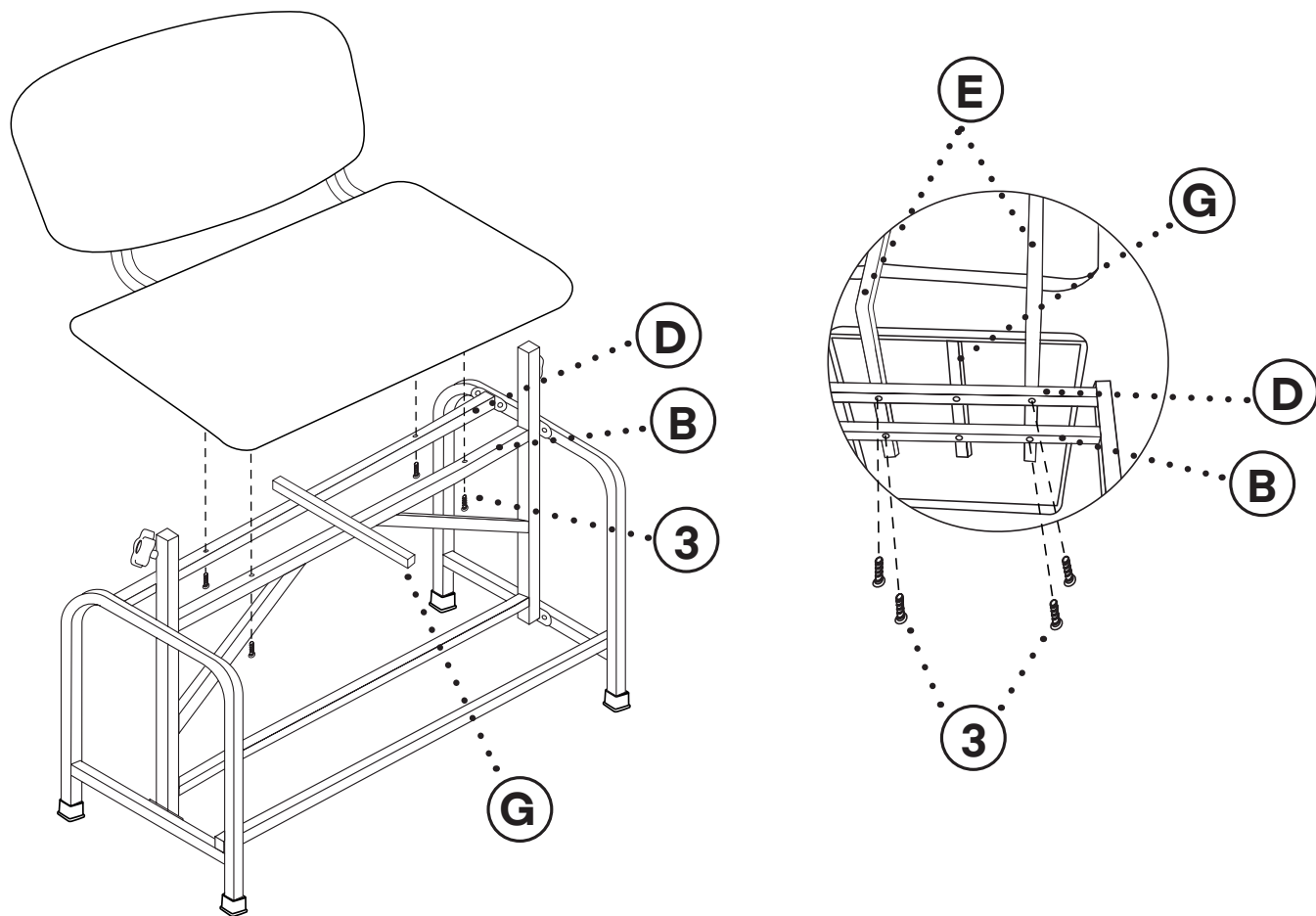

Step 10:

A. Insert two Screw 2's (3) underneath the Arm Rest Cushion (J) through the Armrest Frame (F).

B. Tighten the screws until secure and repeat the steps for the remaining armrest.

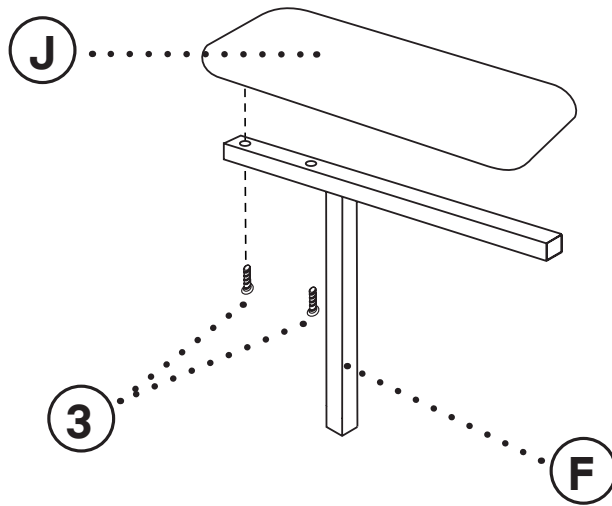

Step 11:

A. Locate the assembled left and right armrests, insert them into the left and right poles, as pictured below.

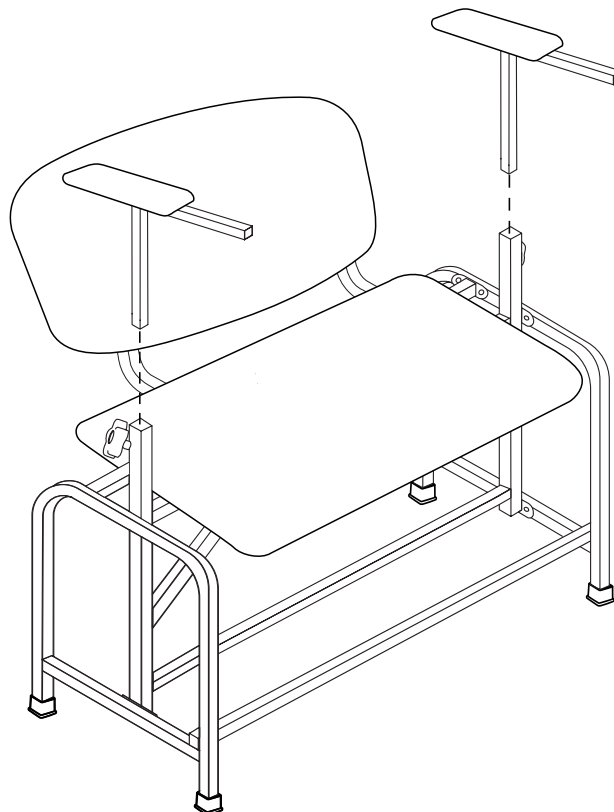

Step 12:

A. Locate and insert both Front Flip Armrests (K) into the left and right armrests.

B. Insert the two remaining Adjustment Knobs (1), as pictured, under the Front Flip Armrests (K).

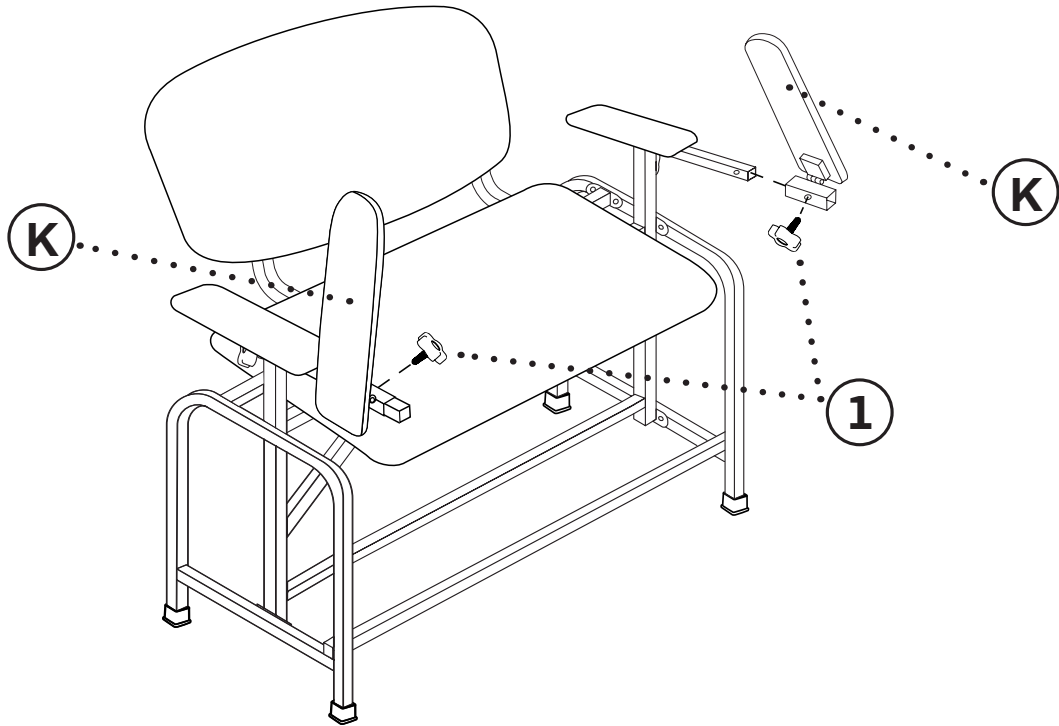

Step 13:

A. Ensure all your screws are tightened and secure.

B. Your Blood Drawing Chair is now ready to be used.

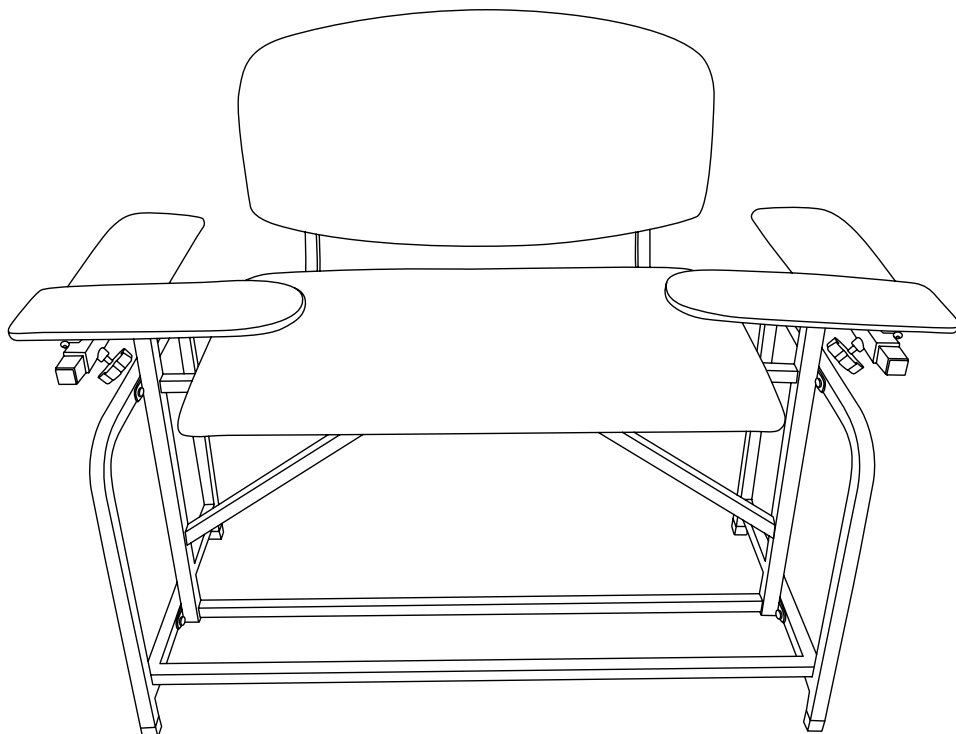

Care & Maintenance Guide

Disclaimer: Viva Comfort will not be held responsible for any damage to the upholstery or surfaces of our products due to cleaning attempts made, whether correctly or improperly conducted. We will not be liable for any damage to the upholstery or the product surfaces, such as discoloration or deterioration, from attempting to clean.

Thank you for purchasing a Viva Comfort product. We are honored to have your business and serve your medical equipment needs. To ensure your product(s) stay in optimal condition, even with consistent use, we have crafted a Care & Maintenance Guide to help you properly maintain and sanitize your product. Please carefully read these guidelines and follow the recommendations listed. Please contact our customer service representatives if you have any questions regarding these instructions.

Note: Be mindful when using sharp or pointed objects in the vicinity of upholstery and exam tables. They can cause damage to the exam table surfaces and puncture or tear the upholstery.

Note: DO NOT use pumice stones, scouring pads, steel wool, or textured cleaning pads to clean any surface of the exam table or the upholstery. We recommend a microfiber towel or a soft cloth.

Note: DO NOT store steel wool on/in your exam tables or on your upholstery.

Upholstery Cleaning:

Viva Comfort uses premium antimicrobial upholstery on all our exam tables. Consistent care should be taken to maintain the upholstery's integrity. We recommend that you always test the solutions below on an inconspicuous spot before using them on the entire upholstery. The below solutions still require you, the user, to follow proper and safe handling of the products. Carefully review all warnings on the labels of any cleaning agents you utilize and ensure it's compatible with our upholstery.

The following Cleaners, Cleaning Materials, and Chemical Makeups will deteriorate and cause permanent damage to your upholstery.

Please Note: Should anything spill on your upholstery, wipe it up immediately and rinse it several times with water to avoid damage.





- Avoid using acidic or abrasive cleaners, as they can cause damage to your upholstery.
- Avoid using dyes (hair, textile, food) near your exam tables as they will permanently stain your upholstery. Should a dye spill occur, wipe it up as soon as possible with dishwashing detergent or an all-purpose cleaner. This is not guaranteed to solve the problem, it but can help reduce the chance of staining.
- Avoid using drainer cleaners or rust removers near your upholstery. Should drain cleaner spill, wipe it up as soon as possible, and rinse it several times with water. Should rust remover spill, wipe off all residue immediately, wash the area with dishwashing soap, and rinse it several times. Ensure you thoroughly dry the area.

- Avoid using the following products near or on your exam tables, as they will cause damage to the surface that may result in discoloration and/or deterioration.

CHEMICAL COMPOUND	AFFILIATED NAMES
Silicon Dioxide	Pumice/Pumice Stones, Degreaser
Sodium Hydroxide	Caustic Soda, Caustic, Lye, Soda Lye, Degreaser, Drainer Cleaner
Hydrofluoric Acid	Rust Remover, Toilet Bowl Cleaner, Concrete Cleaner, Metal Polishes
Phosphoric Acid	Tile Cleaner, Toilet Bowl Cleaner, Rust Remover, Concrete Cleaner
Sulfuric Acid	Oleic Acid, Oil of Vitriol, Oleum, Drain Cleaner, Heavy-Duty Acidic Cleaner
Hydrochloric Acid	Muriatic Acid, Hydrogen Chloride, Toilet Bowl Cleaner, Calcium, Lime and Rust Remover

Below are the recommended cleaning instructions for our antimicrobial upholstery.

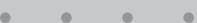
Please Note: DO NOT use any alcohol-based cleaning agents, as this will degrade the upholstery.

MILD SOIL LEVEL 	<p>If the surface is lightly soiled, we recommend using a solution comprised of mild dish soap (10%) mixed in warm water (90%). Saturate a soft towel and clean the upholstery gently. In a separate bucket, have clean water and a soft towel. Thoroughly rinse the upholstery with clean water, as well as dry it completely.</p>
MODERATE SOIL LEVEL 	<p>If the surface is moderately soiled, we recommend using a solution comprised of Fantastik® (50%) and warm water (50%). Saturate a soft towel and clean the upholstery gently. In a separate bucket, have clean water and a soft towel. Thoroughly rinse the upholstery with clean water, as well as dry it thoroughly.</p>
SEVERE SOIL LEVEL 	<p>If the surface is severely soiled, we recommend using a solution comprising of bleach (10%) and warm water (90%). Saturate a soft, white towel and clean the upholstery gently. In a separate bucket, have clean water and a soft, white towel. Thoroughly rinse the upholstery with clean water, as well as dry it completely. Since this solution utilizes bleach, please only use it when necessary; ensure all the bleach solution is removed from the bed, do not let the solution sit on the upholstery, and understand that discoloration may occur.</p>

CHEMICAL NAME	COMPATIBILITY
CloroxPro Healthcare Spore Defense Cleaner, 128 oz.	Yes
CloroxPro Healthcare Hydrogen Peroxide Cleaner, 128 oz.	Yes
CloroxPro Total 360° Disinfectant Cleaner, 128 oz.	Yes
Purell Healthcare Surface Disinfectant Spray, 32 oz.	Yes
CloroxPro Healthcare Bleach Germicidal Wipes, 150 Count	No
CloroxPro Healthcare Versasure Cleaner Disinfectant Wipes, 150 Count	No
PDI Healthcare Sani-Cloth Plus Germicidal Cloth, Pack of 160	No
Alcavis Bleach Wipes, Box of 100	No
CaviWipes Metrex Disinfecting Towelettes, 220 Count	No
Purell Healthcare Surface Disinfecting Wipes, 110 Count	No

Exam Bed Surface Cleaning:

The following Cleaners, Cleaning Materials, and Chemical Makeups will deteriorate and cause permanent damage to your exam beds' surfaces.

Please Note: Should anything spill on your exam table's surface, wipe it up immediately and rinse it several times with water to avoid damage.



- Avoid using acidic or abrasive cleaners, as they can cause damage to your exam table and its upholstery.
- Avoid using dyes (hair, textile, food) near your exam tables as they will permanently stain your table. Should a dye spill occur, wipe it up as soon as possible with dishwashing detergent or an all-purpose cleaner. This is not guaranteed to solve the problem, it but can help reduce the chance of staining.
- Avoid using drainer cleaners or rust removers near your exam table. Should drain cleaner spill, wipe it up as soon as possible, and rinse it several times with water. Should rust remover spill, wipe off all residue immediately, wash the area with dishwashing soap, and rinse it several times. Ensure you thoroughly dry the area.
- Avoid using the following products near or on your exam tables, as they will cause damage to the surface that may result in discoloration and/or deterioration.

CHEMICAL COMPOUND	AFFILIATED NAMES
Silicon Dioxide	Pumice/Pumice Stones, Degreaser
Sodium Hydroxide	Caustic Soda, Caustic, Lye, Soda Lye, Degreaser, Drainer Cleaner
Hydrofluoric Acid	Rust Remover, Toilet Bowl Cleaner, Concrete Cleaner, Metal Polishes
Phosphoric Acid	Tile Cleaner, Toilet Bowl Cleaner, Rust Remover, Concrete Cleaner
Sulfuric Acid	Oleic Acid, Oil of Vitriol, Oleum, Drain Cleaner, Heavy-Duty Acidic Cleaner
Hydrochloric Acid	Muriatic Acid, Hydrogen Chloride, Toilet Bowl Cleaner, Calcium, Lime and Rust Remover

Compatible Household Cleaners For Exam Bed Surfaces

Below is a list of compatible cleaners to use on the exam bed surfaces. We recommend that you always test the solutions below on an inconspicuous spot before using them on the entire surface. The below solutions still require you, the user, to follow proper and safe handling of the products. Carefully review all warnings on the labels of any cleaning agents you utilize and ensure it's compatible with our exam bed surfaces. We will not be liable for any damage to your product surfaces, such as discoloration or deterioration, from attempting to clean.

(These cleaner recommendations are only for exam bed surfaces; DO NOT use the below cleaners on the upholstery. For instructions on how to clean your upholstery, refer to our "Upholstery Cleaning" section.)



Dawn®

Fantastik®

Windex®

Clorox®

Lysol®

Formula 409®

Glass Plus®



Lestoil®

Laminate Surface Cleaning:

Note: Though the tips below are recommended for cleaning soiled and stained areas, we will not be liable for any damage to the product surfaces, such as discoloration or deterioration, from attempting to clean.

Note: The below solutions still require you, the user, to follow proper and safe handling of the products. Carefully review all warnings on the labels of any cleaning agents you utilize and ensure it's compatible with our product.

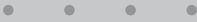
Note: Be sure to utilize proper protective equipment before handling the below cleaning solutions.

MILD SOIL LEVEL 	If the surface is lightly soiled, we recommend using a soft cloth or microfiber towel dampened with a mild soap and water mixture to clean the area.
MODERATE SOIL LEVEL 	If the surface is moderately soiled, we recommend using a solution comprised of a mild household cleaner and baking soda. Create a paste consistency with the recommended cleaning agents, take a nylon bristle brush, and lightly scrub the affected area. DO NOT use a metal bristle brush nor aggressively scrub, or you will cause permanent damage to the surface. Thoroughly rinse the area with clean water, as well as dry it thoroughly.
SEVERE SOIL LEVEL 	If the surface is severely soiled, we recommend using undiluted bleach. Use a cotton pad/ball with bleach on it to gently rub the affected area for a minute or so. Thoroughly rinse the area with clean water, as well as dry it completely. Since this solution utilizes bleach, please only use it when necessary; ensure all the bleach solution is removed from the area, do not let the solution sit on the surface, and understand that discoloration may occur.

-
- Fantastik® is a registered trademark of DowBrands, Inc.®, Registered trademark of the Dow Chemical Co.®
 - Dawn® is a registered trademark of The Procter & Gamble Company®.
 - Windex® is a registered trademark of S.C. Johnson & Son, Inc.®.
 - Clorox® is a registered trademark of The Clorox Company®.
 - Lysol® is a registered trademark of Reckitt Benckiser LLC®.
 - Formula 409® is a registered trademark of The Clorox Company®.
 - Glass Plus® is a registered trademark of Reckitt Benckiser LLC®.
 - Lestoil® is a registered trademark of The Clorox Company®.
 - CloroxPro Healthcare Spore Defense Cleaner, 128 oz. is a registered trademark of The Clorox Company®.
 - CloroxPro Healthcare Hydrogen Peroxide Cleaner, 128 oz. is a registered trademark of The Clorox Company®.
 - Purell Healthcare Surface Disinfectant Spray, 32 oz. is a registered trademark of Gojo industries
 - CloroxPro Total 360o Disinfectant Cleaner, 128 oz., and Purell Healthcare Surface Disinfectant Spray, 32 oz. is a registered trademark of The Clorox Company®.
 - CloroxPro Healthcare Bleach Germicidal Wipes, 150 Count is a registered trademark of The Clorox Company®.
 - CloroxPro Healthcare Versasure Cleaner Disinfectant Wipes, 150 Count is a registered trademark of The Clorox Company®.
 - PDI Healthcare Sani-Cloth Plus Germicidal Cloth, Pack of 160 is a registered trademark of Nice-Pak Products, Inc.
 - Alcavis Bleach Wipes, Box of 100 is a registered trademark of Angelini Pharma Inc.
 - CaviWipes Metrex Disinfecting Towelettes, 220 Count is a registered trademark of Metrex Research.
 - Purell Healthcare Surface Disinfecting Wipes, 110 Count is a registered trademark of Gojo industries.

Warranty

1. Viva Comfort (the "Company" or "Tiger Companies") warrants to the purchaser that the product will be free from defects in workmanship and materials for a period of 1 year from the date of purchase. The warranty period is not extended if we repair, replace, exchange, or provide a refund for the product (as determined in our sole discretion). We may change the availability of this limited warranty at our discretion, but any changes will not be retroactive.
2. These warranties are not assignable or transferable to any other person, including, without limitation, any subsequent owner or other transferee of the product.
3. This Warranty does not apply to: (a) damage caused by misuse, tampering, abuse, neglect, or accident; (b) damage caused by improper installation, modification, or service; (c) alteration of the serial number; or (d) use that violates the instructions furnished by the Company will void this warranty.
4. The sole responsibility of the Company shall be limited to (a) the repair or replacement (in its sole discretion) of any component of the product which fails to conform to this; (b) a refund the purchase price of such product (in its sole discretion), at no cost to the purchaser for the period of the warranty, or (c) an exchange for a similar product, comparable in function and price.
5. Contact the Company directly at 1-(800)-805-1790 to obtain service under this warranty. If it becomes applicable to send a defective product to the Company, a Return Authorization Number must first be obtained from the Company. In order to obtain service under this warranty, purchaser may be required to provide the Company with the following items (a) proof of purchase, (b) photographs and or videos (of the damage, and (c) a written testimonial describing the defect.
6. Products shipped without prior Return Authorization and Return Authorization Number may not be accepted, and the Company will not be responsible for their disposition and/or cost of return to the owner.
7. The Company will not assume any responsibility for any loss or damage incurred in shipping and or delivery.
8. The product(s) must be returned within 14 calendar days of receiving the return authorization from the Company and must include the original proof of purchase for the warranty to be honored.
9. Any implied warranties that the purchaser may have are limited to the duration of the warranties described above. There are no further warranties that extend or apply beyond the face hereof, and the Company expressly disclaims and excludes any and all warranties of merchantability or fitness for a particular purpose. Some states do not allow limitations on how long an implied warranty lasts, so the above limitation may not apply to you.
10. THE REMEDIES DESCRIBED ABOVE ARE YOUR SOLE AND EXCLUSIVE REMEDIES AND THE COMPANY'S ENTIRE LIABILITY FOR ANY BREACH OF THIS LIMITED WARRANTY. OUR LIABILITY SHALL UNDER NO CIRCUMSTANCES EXCEED THE ACTUAL AMOUNT PAID BY YOU FOR THE DEFECTIVE PRODUCT, NOR SHALL WE UNDER ANY CIRCUMSTANCES BE LIABLE FOR ANY CONSEQUENTIAL, INCIDENTAL, SPECIAL OR PUNITIVE DAMAGES OR LOSSES, WHETHER DIRECT OR INDIRECT. SOME STATES DO NOT ALLOW THE EXCLUSION OR LIMITATIONS OF INCIDENTAL OR CONSEQUENTIAL DAMAGES, SO THE LIMITATION MAY NOT APPLY TO YOU.
11. This warranty gives you specific legal rights, and you may also have additional rights which vary from state to state.

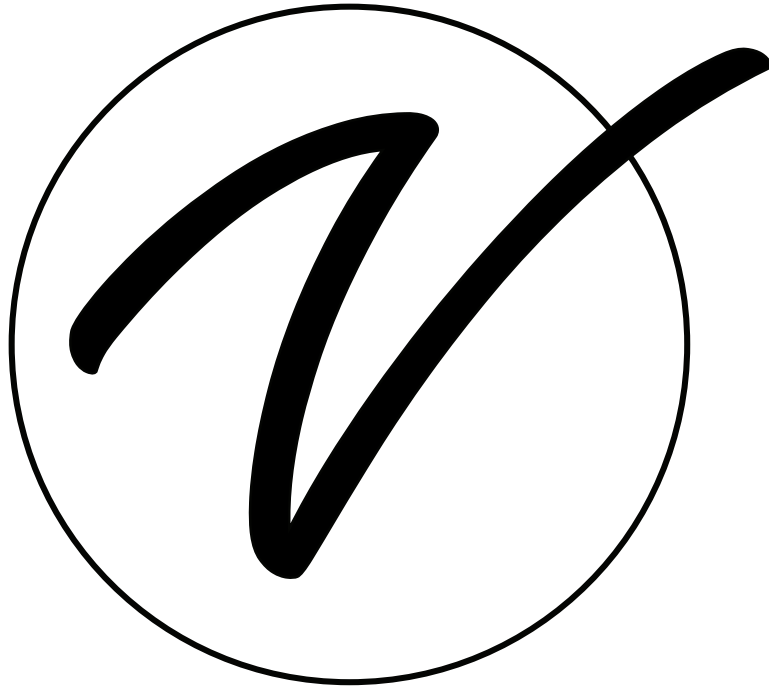

ADI997-01-BT-SERIES

© 2025 Viva Comfort

vivacomfort.com