

.....

# STAINLESS STEEL VETERINARY SCALE

.....

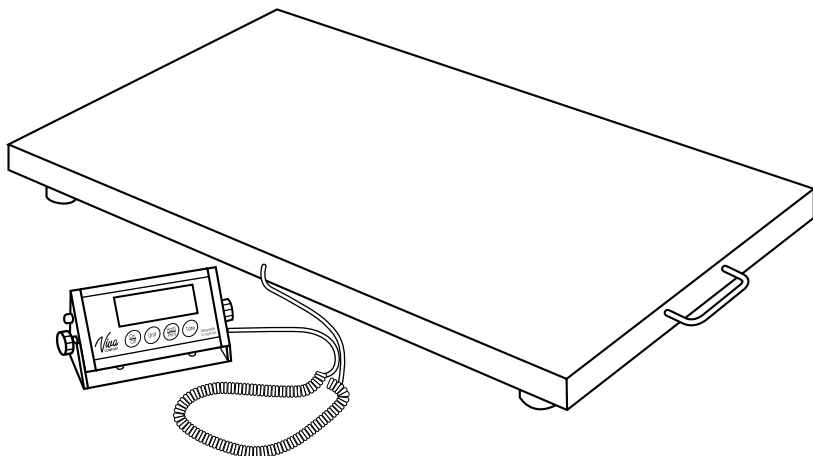

**USER GUIDE**  
ADIME904-04



# Thank you for your purchase.

---

**Viva Comfort maintains a strong practice of ongoing development of products and commercial research.**

---

We recognize that starting and maintaining a medical practice is expensive. We'll help make the process cost-effective and elegant. Additionally, our team of specialists will ensure everything you need works as efficiently as possible, so you can effectively treat your clients.

# Table of Contents

- 2** Parts List
- 3** Tools Needed
- 3** Button Functions
- 4** Assembly Instructions
- 5** Operational Method
- 12** Malfunction
- 13** Specification
- 14** Warranty

# Parts List

A. Base

B. Indicator

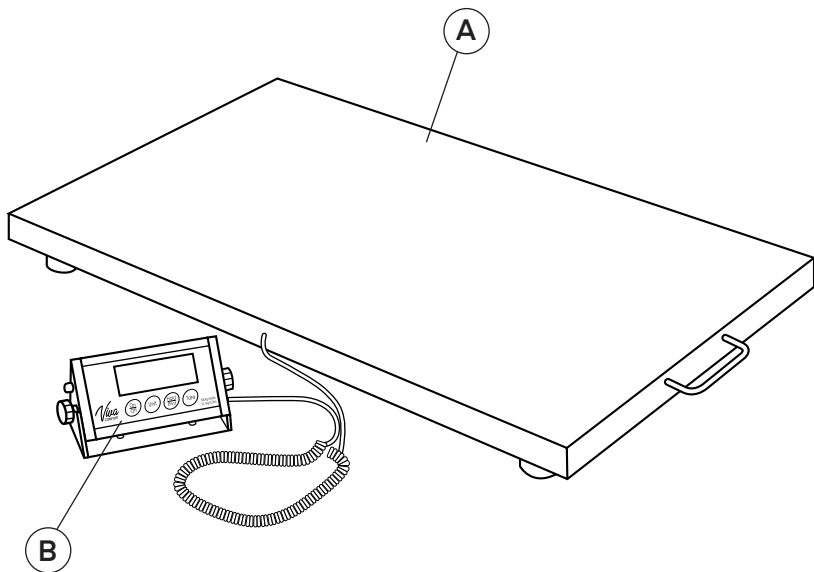

# Hardware List

1

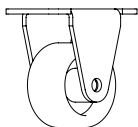

Wheel (x2)

2



M3\*6 Screw (x8)

## Tools Needed (But Not Included)

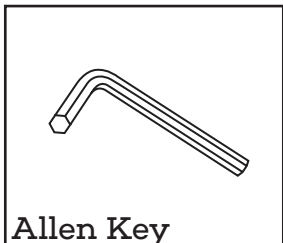

## Button Functions

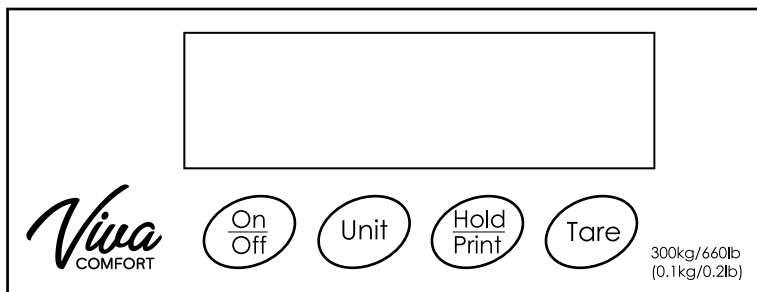

Name	Function	Menu Function	Serial Port Instruction Code
ON/OFF	Turn on/off	Null	O
UNIT	Switch the unit	Scroll down the menu or parameters	U
HOLD/ PRINT	Hold Function/ Output Printing	Scroll up the menu or parameters	H
TARE	Tare	Enter the menu or confirm to change parameter.	T

# Assembly Instructions:

## Step 1:

- A. To install the Wheels (1) onto the scale, flip the Base (A) of the scale over.
- B. Locate one of the Wheels (1) and four of the Screws (4).
- C. Line up the Wheel's (1) mounting plate to the front four predrilled holes, as pictured below.
  - a. Secure the Wheel (1) in place with the four Screws (4).
- D. Repeat the above steps with the remaining Wheel (1).

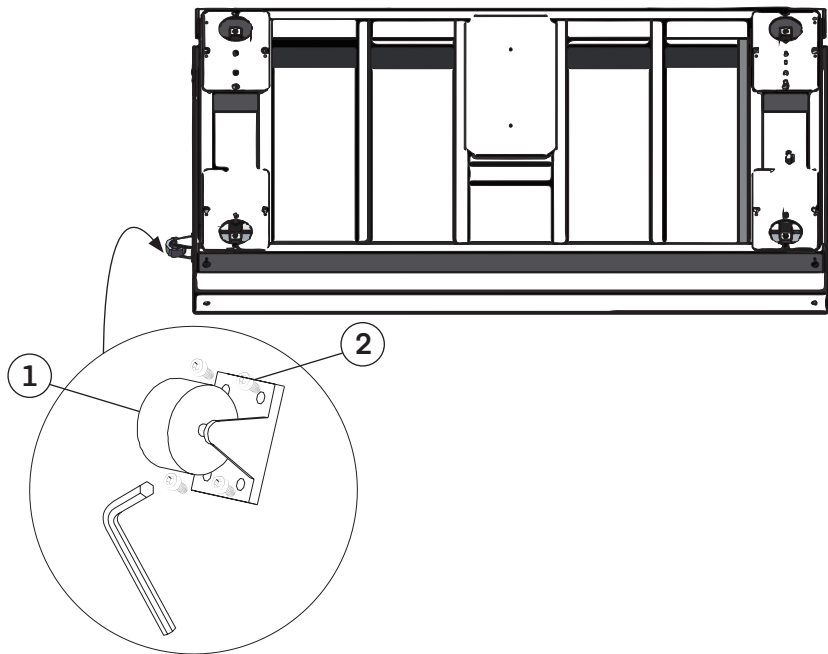

# Operational Method:

## Installing the Power Adapter:

- A. Insert the plug of the AC Adapter into the supply hub located on the left of the display indicator.
- B. Insert the AC Adapter into the AC socket.

## Loading The Batteries:

- A. Open the battery cover located on the right side of the display indicator, load four AAA alkaline cells into the cell box.
  - a. Pay close attention to the polarities of the alkaline cells.
  - b. Close the battery cover once successfully installed.

## Turn On:

- A. First, make sure nothing is on the scale before powering it on.
- B. Press the "On/Off" button; it will show all the characters and then all the versions of numbers.
- C. After the screen displays a "0", you can begin to weigh objects/animals.

## Turn Off:

- A. Press the "On/Off" button once to turn off the scale.

## Weighing:

- A. To begin weighing, ensure your scale is on.
- B. Press the "Tare" button once to make the indicator display a "0".
- C. Put the object/animal in the middle of the scale platform.
  - a. After the kg., lb., or pcs. character stops flashing, you can begin to read the weight.

## Calibration - Single Point:

- A.** To calibrate, press and hold the "UNIT" button until the window displays "-----."
- B.** Press the "UNIT" or "HOLD" button to switch functions and make the window display "CAL."
- C.** Press the "TARE" button to ensure you enter calibration mode.
- D.** Once you've entered calibration mode, the window will display "Load" and "0.0 kg" alternately.
  - a.** This means that the weight "0.0 kg" should be loaded on the platform.
- E.** After making sure that there is nothing on the platform, press the "TARE" button to confirm.
  - a.** This way, the scale begins at a "0.0 kg" calibration.
  - b.** In the process of "0.0 kg" calibration, the "0.0 kg" will flicker rapidly on the display window.
    - i.** Do not touch, nudge, or press anything to the scales platform at this point.
  - c.** If the scale remains stable for over 2 seconds, the scale will finish the "0.0 kg" calibration automatically and continue with the next calibration.
  - d.** If the "0.0 kg" continues to flicker, it is waiting until there is a stable weight.
- F.** Suppose that the next calibration point should be "xx.x kg" the window will display "LOAD" and "xx.x kg" alternately, which means that the weight "xx.x kg" should be loaded onto the platform.

## Calibration - Single Point:

- G.** If you have to change this weight, you can short-press the "UNIT" button or the "HOLD" button to enter the modified menu.
  - a.** Press the "UNIT" button to change the flashing position and then press the "HOLD" button to make the flashing position's number plus 1.
  - b.** Press the "TARE" button to make sure the modification is finished.
- H.** After making sure the weight on the platform is "xx.x kg", press the "TARE" button to confirm so that the scale begins the "xx.x kg" calibration.
- I.** While calibrating, the "xx.x kg" will flicker rapidly on the display window.
  - a.** Do not touch, nudge, or press anything to the scales platform at this point.
  - b.** If the scale remains stable for over 2 seconds, the scale will finish the "0.0 kg" calibration automatically and continue with the next calibration.
  - c.** If the "0.0 kg" continues to flicker, it is waiting until there is a stable weight.

## Changing The Unit:

- A.** Press the "UNIT" button to switch the weighing units between kg., lb., pcs.

## **Hold Function:**

- A.** When the “HOLD” button is pressed the following occurs:
  - a.** The CPU will send weight data into the USB or RS232 socket.
  - b.** The weight will remain on the display for 120 seconds after the item has been removed from the scale so that the weight can be easily read.
- B.** Place an item on the scale platform.
  - a.** Wait for the stable weights to be displayed.
  - b.** Press the “HOLD” button and “▶” will display.
  - c.** Remove the object from the platform; the weight reading will remain on the display for 120 seconds.
  - d.** To exit the hold, once the item is weighted and the hold function has been enabled, press the “HOLD” button again.
    - i.** This will cancel the “▶” hold indicator and return the scale to the weight value.

## **Animal Weighing:**

- A.** When the machine is on, press and hold the “TARE” button until it displays either “OFF” or “ON”.
  - a.** This means open or close the function of animal weighing.
- B.** When the action symbol, located above the until symbol, begins to flash, this will indicate the current model is animal mode.
  - a.** Once the weighing is locked, it will automatically remain at the locked weight for about 10 seconds.

## Counting Sample:

- A.** When trying to count, remove unrelated objects on the platform, and then press the "TARE" button to go back to zero.
- B.** Press the "UNIT" button to switch the unit to "PCS", and the window will display "ADD10".
  - a.** "ADD10" means that 10 objects that need to be weighed, should be added to the platform.
  - b.** The weight of each sample should be higher than the scale's minimum division value.
    - i.** If not, the window will display wrong cute "no".
  - c.** If you want to change the sampling quantity, press the "HOLD" button to change the quantity.
    - i.** If you don't need to sample again, please press the "UNIT" button to cancel the sampling and then the scale will adopt the last sampling value to count.
- C.** After you confirm the quantity of the objects on the platform. And the date displayed on the LCD are the same, press the "TARE" button to confirm.
  - a.** Then proceed with the sample and count.
- D.** During the process of sampling and counting, the screen will display the sampling data accompanied by rapid flickering.
  - a.** Do not touch, nudge, or press anything to the scale's platform at this point.
  - b.** If the weighing remains stable exceeding 2 seconds, the sampling and counting will automatically finish.
    - i.** The parameter will be saved automatically and the scale will return the counting mode.
  - c.** If not, the screen will keep flickering the data until the scale stabilizes.

## **Set User Parameter:**

- A.** When the machine is off, press and hold the "UNIT" button together with the "ON/OFF" button to turn the scale on.
  - a.** DO NOT release the "UNIT" button until the screen displays "-----".
- B.** Press the "UNIT" or "HOLD" button to switch to the menu.
- C.** Press the "TARE" button to enter the display menu.
- D.** After entering the display menu, short-press the "UNIT" or "HOLD" button to select the parameters.
- E.** Press the "TARE" button to confirm the parameter and return to the menu.
- F.** After all the parameters have been set, switch the menu into "END", and press the "TARE" button to finish the setting and save the parameters.
  - a.** Return to the weighing or counting mode.

## User Parameter

Menu	Meaning of Menu	Selectable Parameter	Meaning of Parameter
<b>codE</b>	Check the internal code	Null	Check the internal code for debugging by manufacturer.
<b>ASt</b>	Zero tracking range	0.5/1/2/3d	Set automatic zero tracking range.
<b>out</b>	Printout method	kEy/Auto/Conti	kEy: Printout while pressing the key, Auto: Printout Automatically, Conti: Printout Continuously
<b>LEd</b>	Backlight control method	OFF/Auto/ON	OFF: back light is turned off, Auto: back light is automatic, On: back light is turned on.
<b>OFF</b>	Automatic shutdown control	no/3/5/10/15/30/60 min	no: no automatic shutdown. 3~60min: if there is not any action of weighing objects or pressing buttons, the instrument will automatically turn off.
<b>-LL-</b>	Set Lower limit alarm	xxxx (lower limit value)	If the lower limit value is set to "0", the lower limit alarm function is canceled.
<b>-HH-</b>	Set upper limit alarm	xxxx (upper limit value)	If the upper limit value is set to "0", the upper limit alarm function is canceled.
<b>-End-</b>	Finish measuring and save the parameters	Null	

## Meaning of Cue Code

Display Code	Meaning of Code	Solution
no	1. The calibration weight value is not loaded according to the display when calibrating. 2. The quantity of objects is not loaded according to the quantity of sampling.	1. Load the weight value according to the show value. 2. Load the quantity according to the show value.
AC	The batteries are low/dead.	1. Use new batteries. 2. Use power adapter.
Err-O	1. Lost the calibration data. 2. The load cell or main board maybe damaged.	1. Re-calibrate. 2. Change the load cell or main board.
Err-1	1. The weight is over the max capacity. 2. Lost the calibration data. 3. The load cell or main board might be damaged.	1. Remove the objects on the platform. 2. Re-calibrate. 3. Change the load cell or main board.
--L--	Lower Limit Alarm	1. Cancel Lower Limit Alarm
--H--	Upper Limit Alarm	1. Cancel Upper Limit Alarm

### Maintenance of Scale:

- A.** In order to keep the scale in normal operation, the crust of the indicator and the platform should be kept clean and prevented from corrosion by foreign substance.
- B.** If necessary, you should use a piece of cloth with a mild washing agent to clean them.
- C.** When the scale isn't in use, pull out the A/C plug.
- D.** When the scale isn't in use for a long time, remove the batteries.

# Malfunction

Phenomenon	Reason	Solution
No display	The power plug is not inserted in right place.	Insert the plug in right place.
	The batteries are expired.	Use the new batteries.
Low-voltage indication	The power of batteries is low.	Use the new batteries.
Error in weighing data-reading	The scale didn't back to zero before using.	Do not put objects on the platform, press "TARE" button, and then begin to weigh
	The scale is not calibrated.	
False calibration	The calibration weight is not precise.	Use the precise calibration weight.

# Specification

Model	ADIME904-04
Capacity	300kg/ 660lb
Division	0.1kg/ 0.2lb
Tare Range	To capacity by subtraction
Over Range Capacity	300kg/ 660 Capacity 9d
Stabilization Time	2sec
Operation Temperature	50~104F
Power Requirements	AC adapter;110-240V AC,50/60Hz, Or 4 AAA batteries
Platform Size(in/mm)	44.09" (1120) × 20.47" (520)
Product Size(mm)	44.09" (1120) × 20.47" (520) × 1.77" (45)

# Warranty

1. Viva Comfort (the "Company" or "Tiger Companies") warrants to the purchaser that the product will be free from defects in workmanship and materials for a period of 1 year from the date of purchase. The warranty period is not extended if we repair, replace, exchange, or provide a refund for the product (as determined in our sole discretion). We may change the availability of this limited warranty at our discretion, but any changes will not be retroactive.
2. These warranties are not assignable or transferable to any other person, including, without limitation, any subsequent owner or other transferee of the product.
3. This Warranty does not apply to: (a) damage caused by misuse, tampering, abuse, neglect, or accident; (b) damage caused by improper installation, modification, or service; (c) alteration of the serial number; or (d) use that violates the instructions furnished by the Company will void this warranty.
4. The sole responsibility of the Company shall be limited to (a) the repair or replacement (in its sole discretion) of any component of the product which fails to conform to this; (b) a refund the purchase price of such product (in its sole discretion), at no cost to the purchaser for the period of the warranty, or (c) an exchange for a similar product, comparable in function and price.
5. Contact the Company directly at 1-(800)-805-1790 to obtain service under this warranty. If it becomes applicable to send a defective product to the Company, a Return Authorization Number must first be obtained from the Company. In order to obtain service under this warranty, purchaser may be required to provide the Company with the following items (a) proof of purchase, (b) photographs and or videos (of the damage, and (c) a written testimonial describing the defect.
6. Products shipped without prior Return Authorization and Return Authorization Number may not be accepted, and the Company will not be responsible for their disposition and/or cost of return to the owner.
7. The Company will not assume any responsibility for any loss or damage incurred in shipping and or delivery.
8. The product(s) must be returned within 14 calendar days of receiving the return authorization from the Company and must include the original proof of purchase for the warranty to be honored.
9. Any implied warranties that the purchaser may have are limited to the duration of the warranties described above. There are no further warranties that extend or apply beyond the face hereof, and the Company expressly disclaims and excludes any and all warranties of merchantability or fitness for a particular purpose. Some states do not allow limitations on how long an implied warranty lasts, so the above limitation may not apply to you.
10. THE REMEDIES DESCRIBED ABOVE ARE YOUR SOLE AND EXCLUSIVE REMEDIES AND THE COMPANY'S ENTIRE LIABILITY FOR ANY BREACH OF THIS LIMITED WARRANTY. OUR LIABILITY SHALL UNDER NO CIRCUMSTANCES EXCEED THE ACTUAL AMOUNT PAID BY YOU FOR THE DEFECTIVE PRODUCT, NOR SHALL WE UNDER ANY CIRCUMSTANCES BE LIABLE FOR ANY CONSEQUENTIAL, INCIDENTAL, SPECIAL OR PUNITIVE DAMAGES OR LOSSES, WHETHER DIRECT OR INDIRECT. SOME STATES DO NOT ALLOW THE EXCLUSION OR LIMITATIONS OF INCIDENTAL OR CONSEQUENTIAL DAMAGES, SO THE LIMITATION MAY NOT APPLY TO YOU.
11. This warranty gives you specific legal rights, and you may also have additional rights which vary from state to state.



**ADIME904-04**

© 2024 Viva Comfort

**[vivacomfort.com](https://vivacomfort.com)**