

.....

ADJUSTABLE UP & DOWN STEEL REHAB STAIRCASE

.....

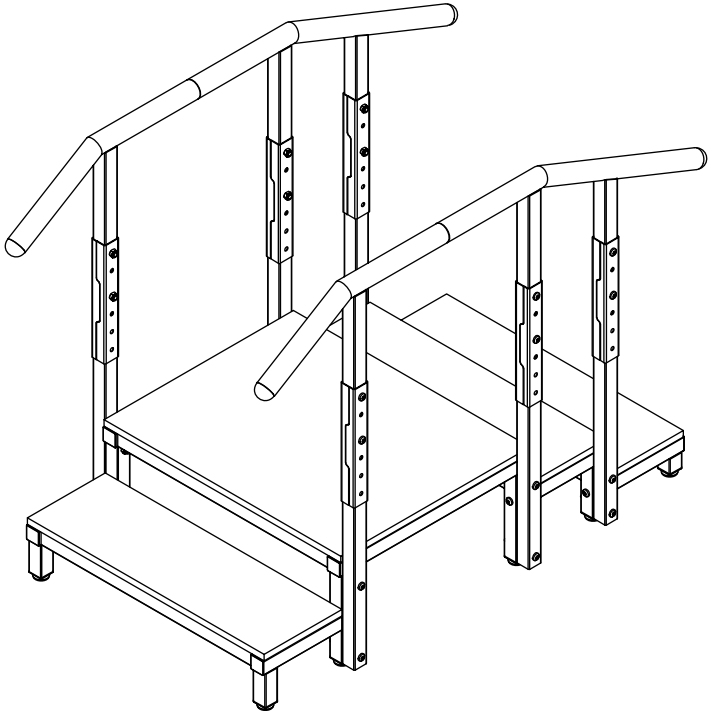

USER GUIDE

SKU: ADI906-04-30





Thank you for your purchase.



Viva Comfort maintains a strong practice of ongoing development of products and commercial research.



We recognize that starting and maintaining a medical practice is expensive. We'll help make the process cost-effective and elegant. Additionally, our team of specialists will ensure everything you need works as efficiently as possible, so you can effectively treat your clients.

Table of Contents

- 4 Parts List
- 5 Hardware List
- 6 Safety Warning
- 7 Usage and Storage Environment Conditions
- 8 Assembly Instructions
- 12 Maintenance
- 13 Warranty Terms
- 14 Warranty
- 15 Notes

Parts List

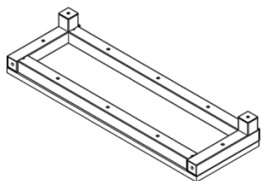
A

Stair Step A

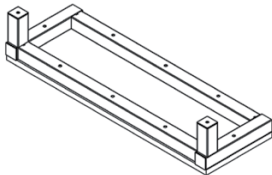
B

Stair Step B

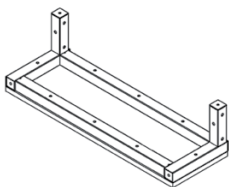
C

Stair Step C

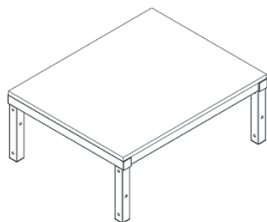
D

Platform

E

Vertical Rod (x6)

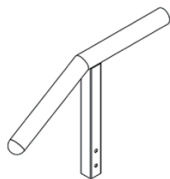
F

Single Arm Guardrail (x2)

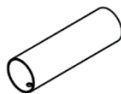

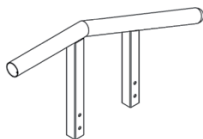

G

Connecting Sleeve (x2)

H

Dual Arm Guardrail (x2)

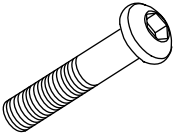
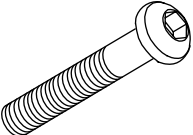
Hardware List

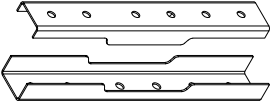

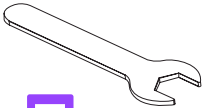
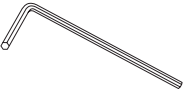
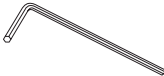

<p>1</p>  <p>Ankle Foot (x10)</p>	<p>2</p>  <p>M10 Lock Nut (x24)</p>
<p>3</p>  <p>Bolt M10*95mm (x12)</p>	<p>4</p>  <p>Bolt M10*55mm (x18)</p>
<p>5</p>  <p>Bolt M8*16mm (x4)</p>	<p>6</p>  <p>Reinforcement Kit (x6)</p>

Tools Needed

<p>7</p>  <p>Open End Wrench M10 (x1)</p>	<p>8</p>  <p>H5 Hex Key (x1)</p>	<p>9</p>  <p>H6 Hex Key (x1)</p>
---	--	--

Safety Warning

The user is responsible for preventing damage to this product and injury to patients and/or users.

	Warning: Indication of potential personal injury.
	Reminder: Keep away from moisture. This device needs to be moisture and waterproof. 
	Reminder: Always place the packaging box in the correct direction during transportation, storage, and handling to avoid damage and safety problems caused by incorrect placement.
	Reminder: This product is fragile and needs to be handled with care.



Risk of Collapse:

If the patient's weight exceeds the working load, the stair steps or handrails may break.



Personnel Injured:

The product is heavy. If you need to transport stairs, please ensure that at least 4 adults are moving it together to avoid accidents.

Usage and Storage Environment Conditions

- A. The ambient temperature requirement for using and storing the equipment is:  40. If the equipment is exposed to an environment exceeding the specified temperature for a long time, it may cause the risk of wood deformation or cracking.
- B. The humidity requirement for equipment transportation, use and storage environment is: 20%~80%. If the equipment is exposed to an overly dry or humid environment for a long time, it may cause the risk of wood deformation or cracking, as well as a risk of metal rusting.
- C. The metal parts of the equipment are ~~strictly~~ prohibited from contacting liquid water, which may cause metal materials to rust.

Other Precautions

- A. ~~It is strictly prohibited to approach fire sources.~~
- B. Do not place it in direct sunlight.
- C. Do not place it in high-temperature places ~~such as heaters.~~

Patient Load Capacity: 500 lbs.

Instructions

Preparation and Inspection before use.

- A. Confirm whether a product manual ~~and warranty card~~ accompany the product.
- B. Confirm whether the installation hardware package is attached.
- C. Confirm whether the components are deformed or damaged.
- D. If any abnormalities occur during installation and use, please get in touch with the ~~dealer~~ in time.

Assembly Instructions

Step 1:

- A.** Please take the product out of the package and place it on a horizontal ground with the steps facing downward. Please lay a blanket on the ground to prevent equipment from damaging the floor.
- B.** Before installation, please find the corresponding parts and their correct positions as shown, arrange the Stair Steps in the order of Stair Step B (B), Platform (D), Stair Step C (C) and Stair Step A (A); and use Bolts M10*55mm (4) to connect the four stair treads as shown. When installing, please use a Allen Key (9) to rotate clockwise and tighten each Bolt,
- C.** Install the Adjustment Foot (1) to each steel foot as shown.

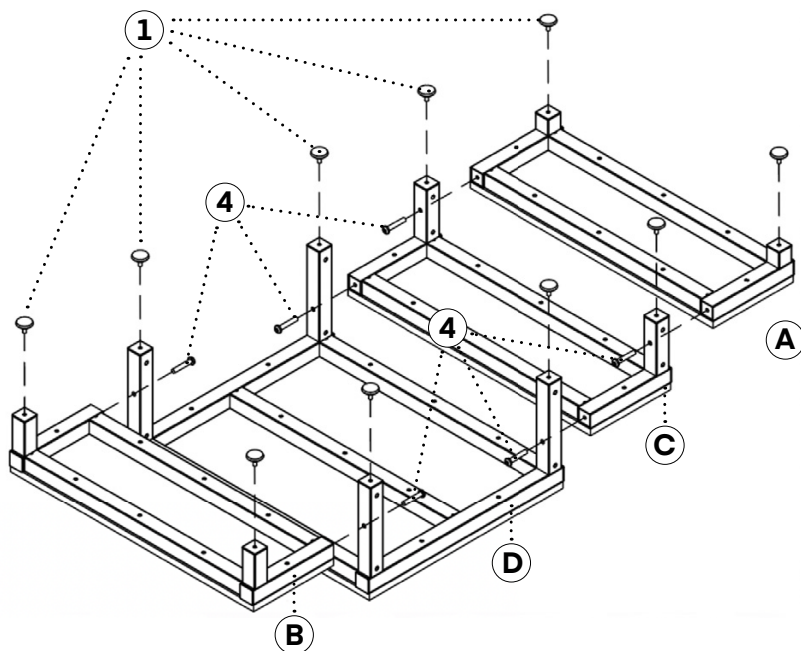

Step 2:

- A. ~~As shown, install the Vertical Rod (E) on both sides of the stair support leg. During installation, insert Bolts M10*95mm (3), through the reserved holes on the Vertical Rod (E) and the reserved holes on the side of the stair leg. Secure them with Locking Nuts (2). A Hex Key (9) and a Open-end Wrench (7) are required for installation. Ensure all Bolts and Nuts are tightened to ensure safety and prevent shaking.~~

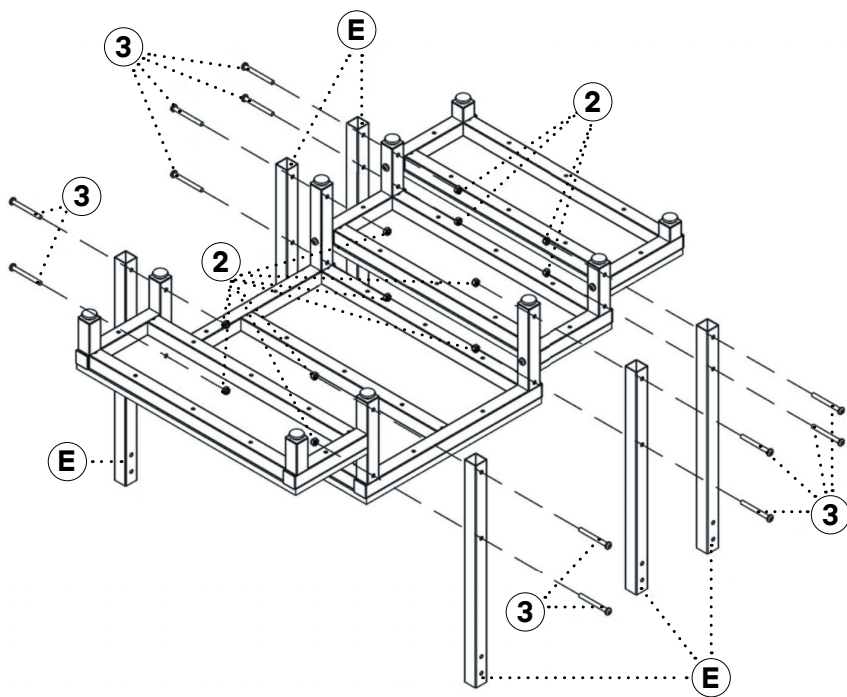

Step 3:

- A. ~~Connect the single-arm Guardrail (F), the Connecting Sleeve (G), and the Dual-Arm Guardrail (H) together, and secure them with Bolts M8*16mm (5). Please use a H5 Hexa Key (8) to tighten the Bolts to ensure safety and prevent shaking.~~

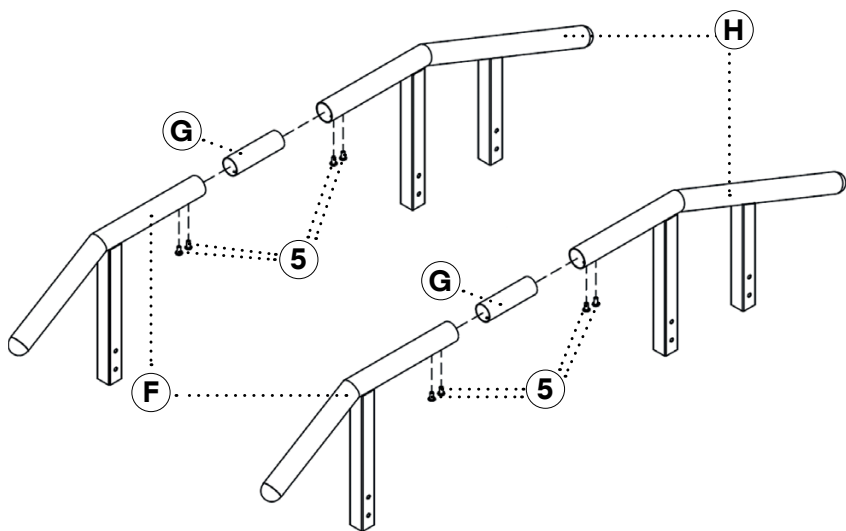

~~During this installation Step 4, please call for assistance to lift the guardrail to prevent it from falling to the ground and causing injury.~~

Step 4:

- A.** Use the Reinforcement Kit (6) to connect the assembled Guardrail to the Vertical Rod (E).

During installation, first determine the Guardrail height and adjust it to the appropriate position to determine which mounting hole on the Reinforcement Kit (6) to use. To secure, place the Reinforcement Kit (6) over both sides of the Guardrail support arm and Vertical Rod (E).

- B.** Use Bolts M10*55mm (4) through the pre-recorded holes and secure with Nuts (2) on the inside. Use a Open-end Wrench (7) and a H6 Hex Key (9) for securing.

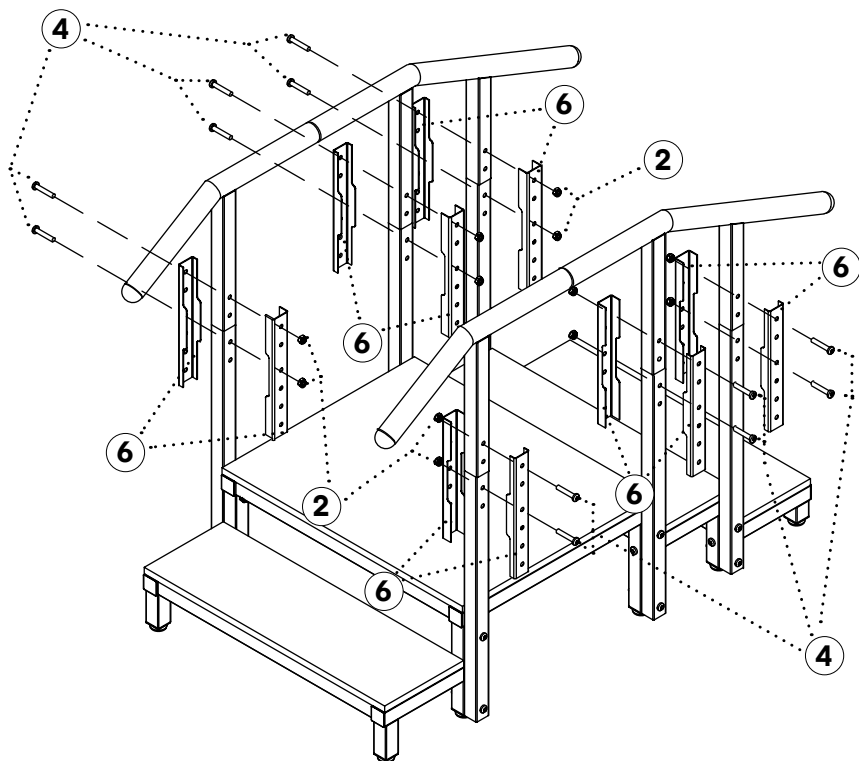



~~After locking all the Bolts at once, it is necessary to tighten each Bolt and Nut again to ensure that each Bolt and Nut are tightened, and check if the Guardrail is shaking. If the Guardrail is shaking, it is necessary to continue tightening the Bolts and Nuts.~~



~~If the Handrail shakes, please stop using it immediately, otherwise all consequences will be borne by the user.~~

Maintenance of Metal and Wood

~~A. A dry towel is recommended to wipe metal and wood.~~

~~B. If disinfection is necessary, it is acceptable to use hypochlorous acid disinfectant or alcohol with a concentration below 70% to the maximum extent possible.~~

~~Using highly corrosive disinfectants is prohibited for disinfection. Otherwise, the wood veneer may be damaged.~~

Regular Maintenance

Check the steps and handrails every 3 months to test its stability when pushed horizontally/vertically/laterally. If there is any shaking, tighten the connecting bolts and nuts.

Warranty Terms

Disclaimer: For equipment failure or unavailability caused by non-human factors, we provide free repair or replacement of accessories. This warranty does not include the following:

- A.** Damage caused by accident, abuse, improper operation or transportation.
- B.** Unauthorized maintenance, repair and modification.
- C.** Equipment failure caused by improper use.
- D.** Damage exceeds the value of the product.
- E.** Damage caused by improper storage.
- F.** Failure to provide proof of purchase date.
- G.** After the warranty period of this product expires, the company can provide paid repair services. After 10 years from the ex-factory date, the product will enter the scrap stage.
- H.** The warranty does not cover packaging and other accessories.

Warranty

1. Viva Comfort (the "Company" or "Tiger Companies") warrants to the purchaser that the product will be free from defects in workmanship and materials for a period of 1 year from the date of purchase. The warranty period is not extended if we repair, replace, exchange, or provide a refund for the product (as determined in our sole discretion). We may change the availability of this limited warranty at our discretion, but any changes will not be retroactive.
2. These warranties are not assignable or transferable to any other person, including, without limitation, any subsequent owner or other transferee of the product.
3. This Warranty does not apply to: (a) damage caused by misuse, tampering, abuse, neglect, or accident; (b) damage caused by improper installation, modification, or service; (c) alteration of the serial number; or (d) use that violates the instructions furnished by the Company will void this warranty.
4. The sole responsibility of the Company shall be limited to (a) the repair or replacement (in its sole discretion) of any component of the product which fails to conform to this; (b) a refund the purchase price of such product (in its sole discretion), at no cost to the purchaser for the period of the warranty, or (c) an exchange for a similar product, comparable in function and price.
5. Contact the Company directly at 1-(800)-805-1790 to obtain service under this warranty. If it becomes applicable to send a defective product to the Company, a Return Authorization Number must first be obtained from the Company. In order to obtain service under this warranty, purchaser may be required to provide the Company with the following items (a) proof of purchase, (b) photographs and or videos (of the damage, and (c) a written testimonial describing the defect.
6. Products shipped without prior Return Authorization and Return Authorization Number may not be accepted, and the Company will not be responsible for their disposition and/or cost of return to the owner.
7. The Company will not assume any responsibility for any loss or damage incurred in shipping and or delivery.
8. The product(s) must be returned within 14 calendar days of receiving the return authorization from the Company and must include the original proof of purchase for the warranty to be honored.
9. Any implied warranties that the purchaser may have are limited to the duration of the warranties described above. There are no further warranties that extend or apply beyond the face hereof, and the Company expressly disclaims and excludes any and all warranties of merchantability or fitness for a particular purpose. Some states do not allow limitations on how long an implied warranty lasts, so the above limitation may not apply to you.
10. THE REMEDIES DESCRIBED ABOVE ARE YOUR SOLE AND EXCLUSIVE REMEDIES AND THE COMPANY'S ENTIRE LIABILITY FOR ANY BREACH OF THIS LIMITED WARRANTY. OUR LIABILITY SHALL UNDER NO CIRCUMSTANCES EXCEED THE ACTUAL AMOUNT PAID BY YOU FOR THE DEFECTIVE PRODUCT, NOR SHALL WE UNDER ANY CIRCUMSTANCES BE LIABLE FOR ANY CONSEQUENTIAL, INCIDENTAL, SPECIAL OR PUNITIVE DAMAGES OR LOSSES, WHETHER DIRECT OR INDIRECT. SOME STATES DO NOT ALLOW THE EXCLUSION OR LIMITATIONS OF INCIDENTAL OR CONSEQUENTIAL DAMAGES, SO THE LIMITATION MAY NOT APPLY TO YOU.
11. This warranty gives you specific legal rights, and you may also have additional rights which vary from state to state.

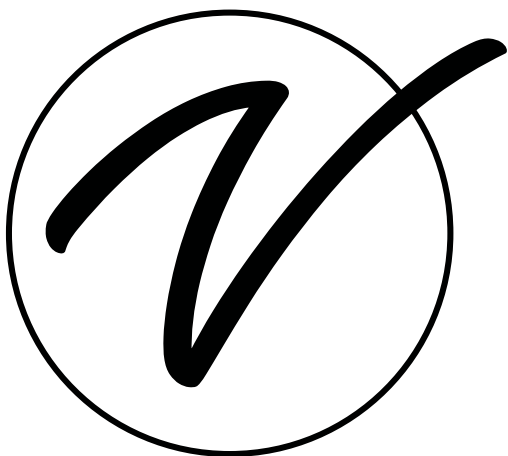

SKU: ADI906-04-30

© 2025 Viva Comfort

vivacomfort.com