

.....

EDAN MONITOR MOUNTING PLATE

.....

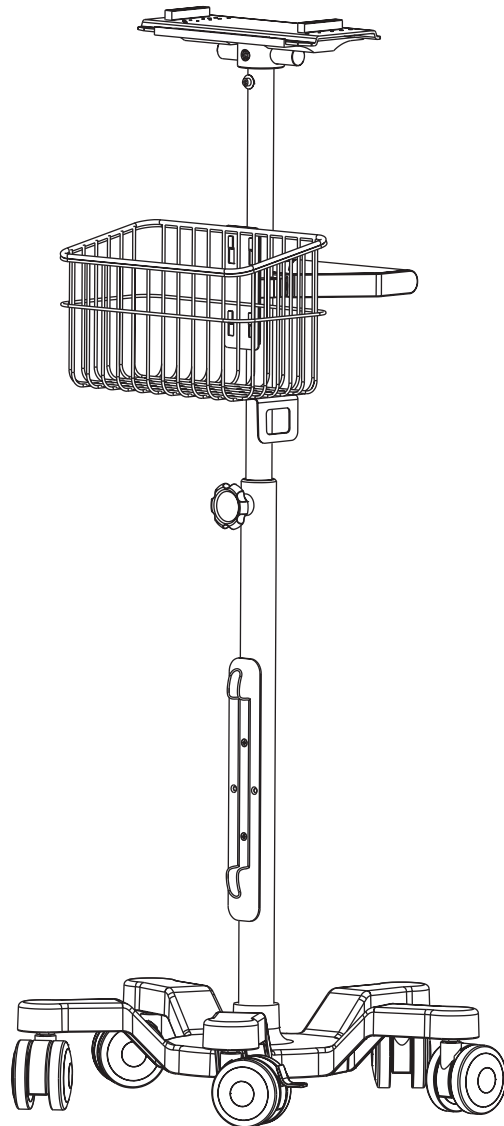

USER GUIDE

SKU: ADIME912-MP-03



Thank you for your purchase.



Viva Comfort maintains a strong practice of ongoing development of products and commercial research.



We recognize that starting and maintaining a medical practice is expensive. We'll help make the process cost-effective and elegant. Additionally, our team of specialists will ensure everything you need works as efficiently as possible, so you can effectively treat your clients.

Table of Contents

- 2** Parts List
- 3** Hardware List
- 4** Assembly Instructions
- 9** X-Series Mounting Instructions
- 10** Warranty
- 11** Notes

Parts List

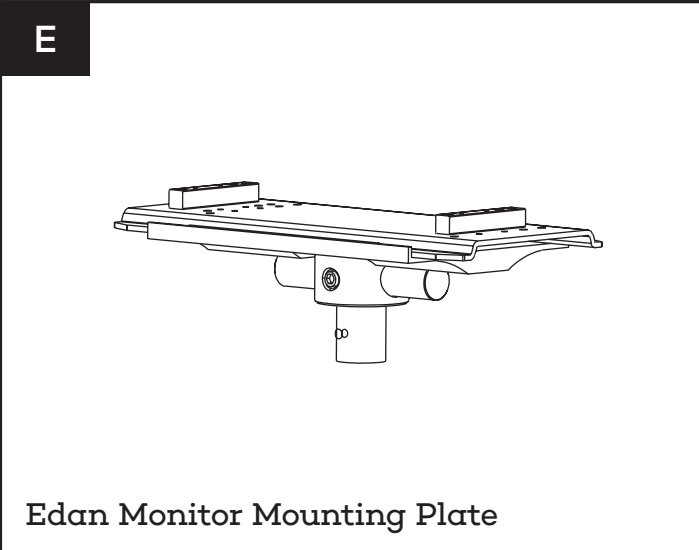
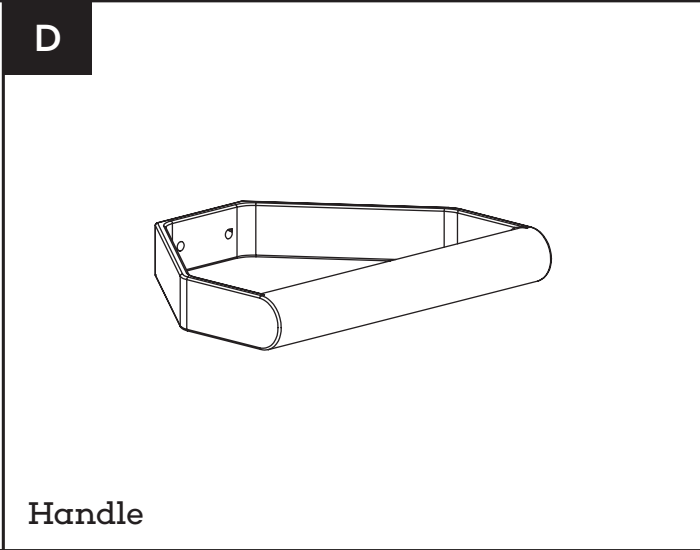
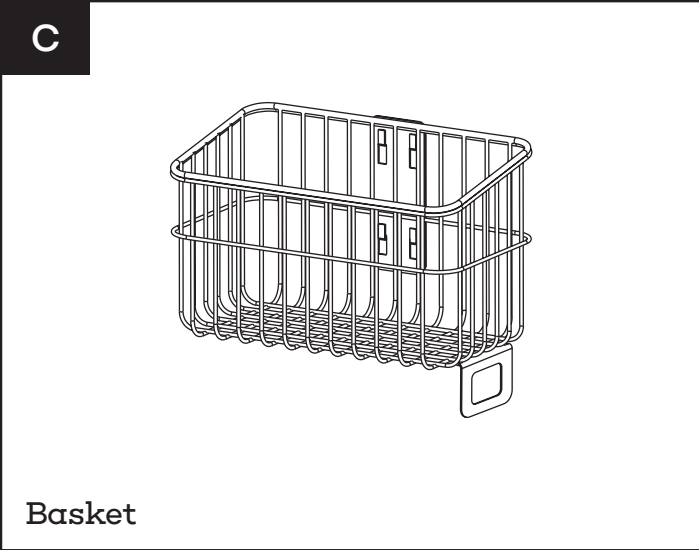
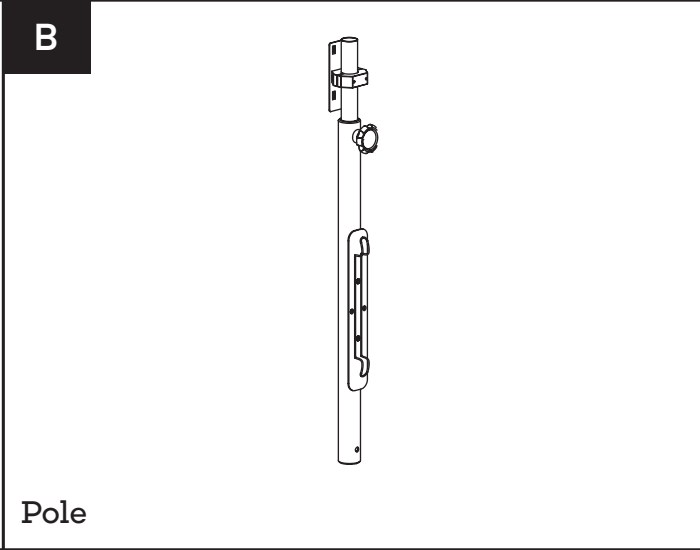
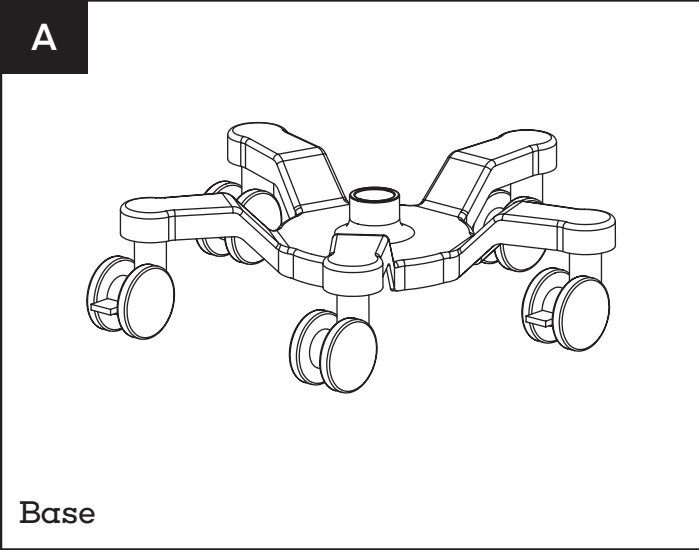

IMPORTANT

.....

* Please note that the Universal Mobile Cart is sold separately.

Hardware List

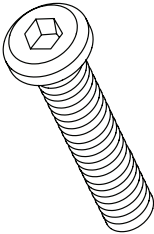
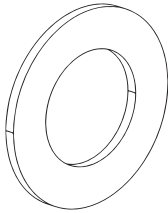
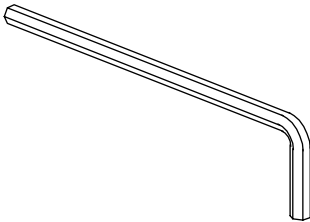
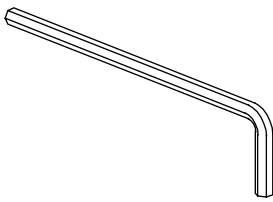
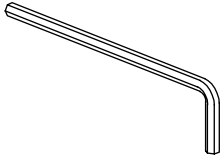
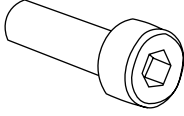
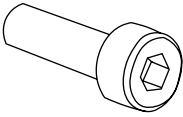
<p>1</p>  <p>Screw (M8x50mm)</p>	<p>2</p>  <p>Gasket</p>
<p>3</p>  <p>6 mm Allen Key</p>	<p>4</p>  <p>4 mm Allen Key (For Adjusting Pole Clamp)</p>
<p>5</p>  <p>3 mm Allen Key</p>	<p>6</p>  <p>Bolt (Preinstalled On Clamp)</p>
<p>7</p>  <p>Mounting Plate Bolt (Preinstalled On Mounting Plate)</p>	

Assembly Instructions

Step 1:

- A.** To assemble the cart, insert the Pole (B) into the central hole of the Base (A).
- B.** Thread the included Gasket (2) over the Screw (1).
- C.** Secure the Pole (B) and Base (A) together by inserting the Screw (1) and Gasket (2) from underneath the Base (A) into the Pole (B).
 - a.** Secure them together using the 6 mm Allen Key (3).

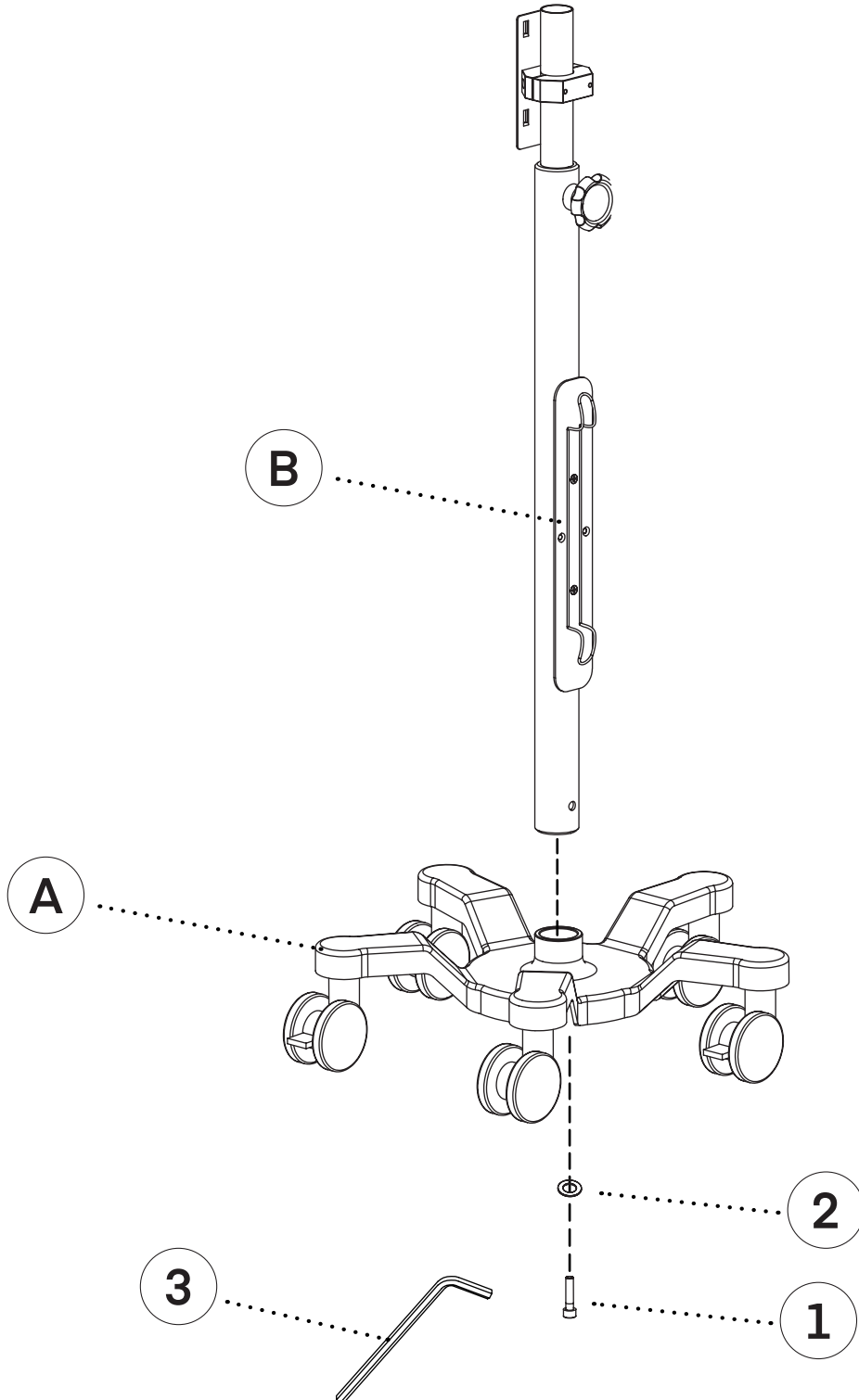

Step 2:

A. Locate the Basket (C) and align it with the preinstalled mounting bracket on the Pole (B).

B. To attach it securely, lift the Basket (C) above the bracket and then slide it down until it locks into place.

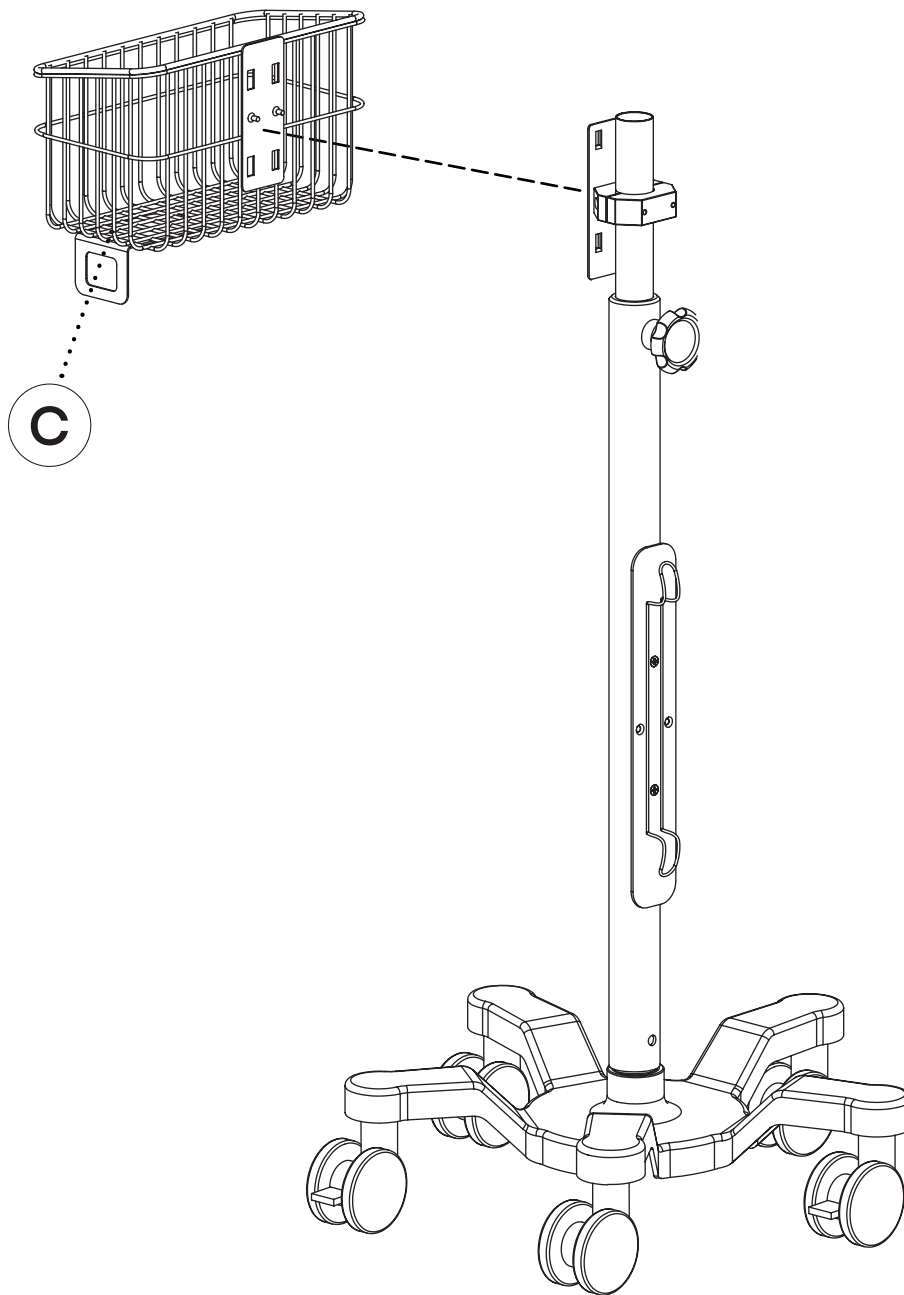

Step 3:

- A.** On the mounting bracket, you'll find a clamp; using the 3 mm Allen Key (5), loosen the two preinstalled Bolts (6) and remove them.
- B.** Locate the Handle (D) and align it with the two holes from which you removed the Bolts (6).
 - a.** Insert the Bolts (6) through the Handle (D) and into the clamp.
- C.** Securely fasten the Bolts (6) using the 3 mm Allen Key (5).

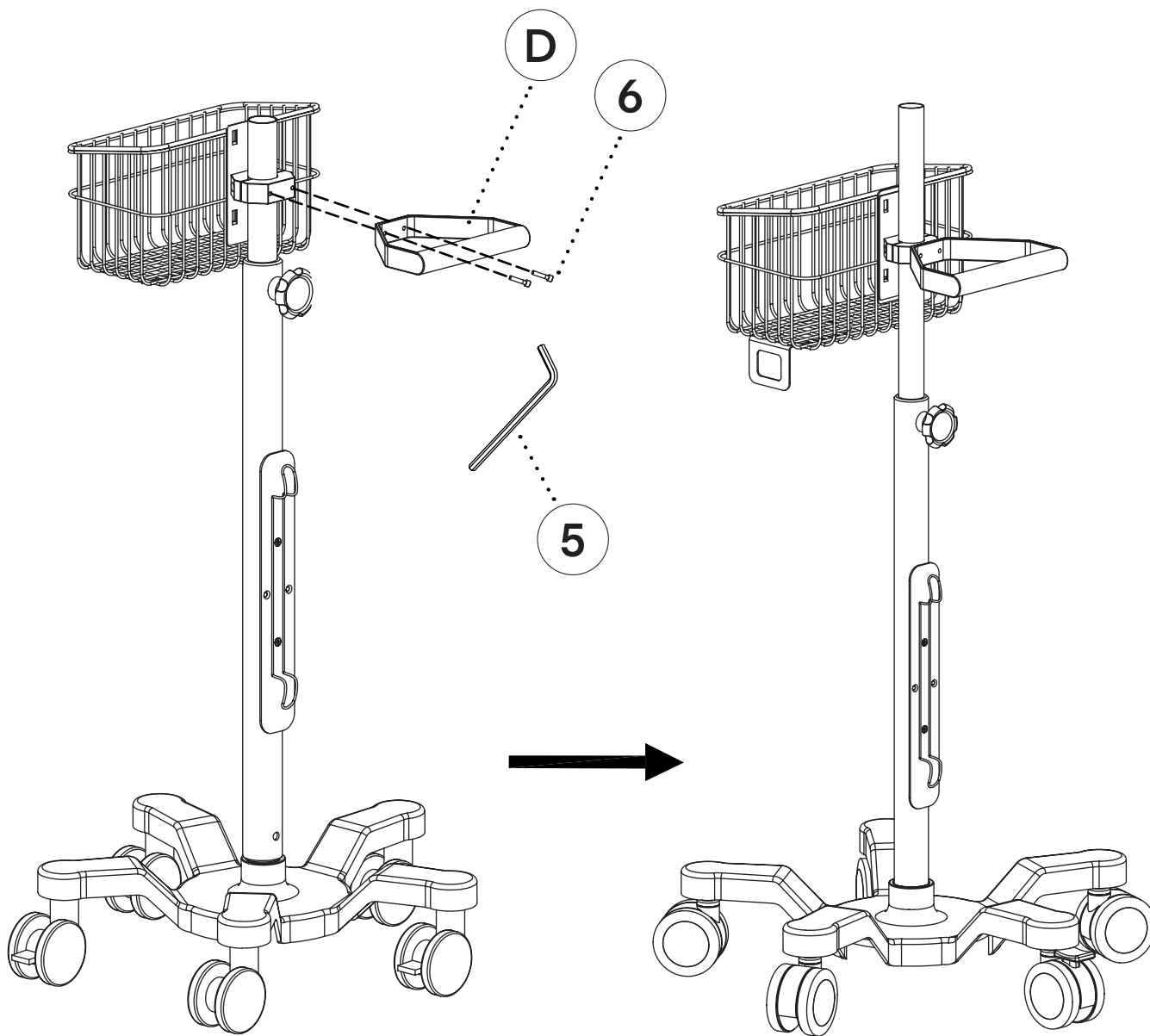

Step 4:

- A.** To install the Edan Monitor Mounting Plate (E), start by using the 3 mm Allen Key (5) to remove the preinstalled Mounting Plate Bolt (7) from the mounting plate.
- B.** Insert the Edan Monitor Mounting Plate (E) into the top of the Pole (B).
- C.** Reinstall the Mounting Plate Bolt (7) into the mounting plate and the Pole (B), then tighten it securely using the 3 mm Allen Key (5).

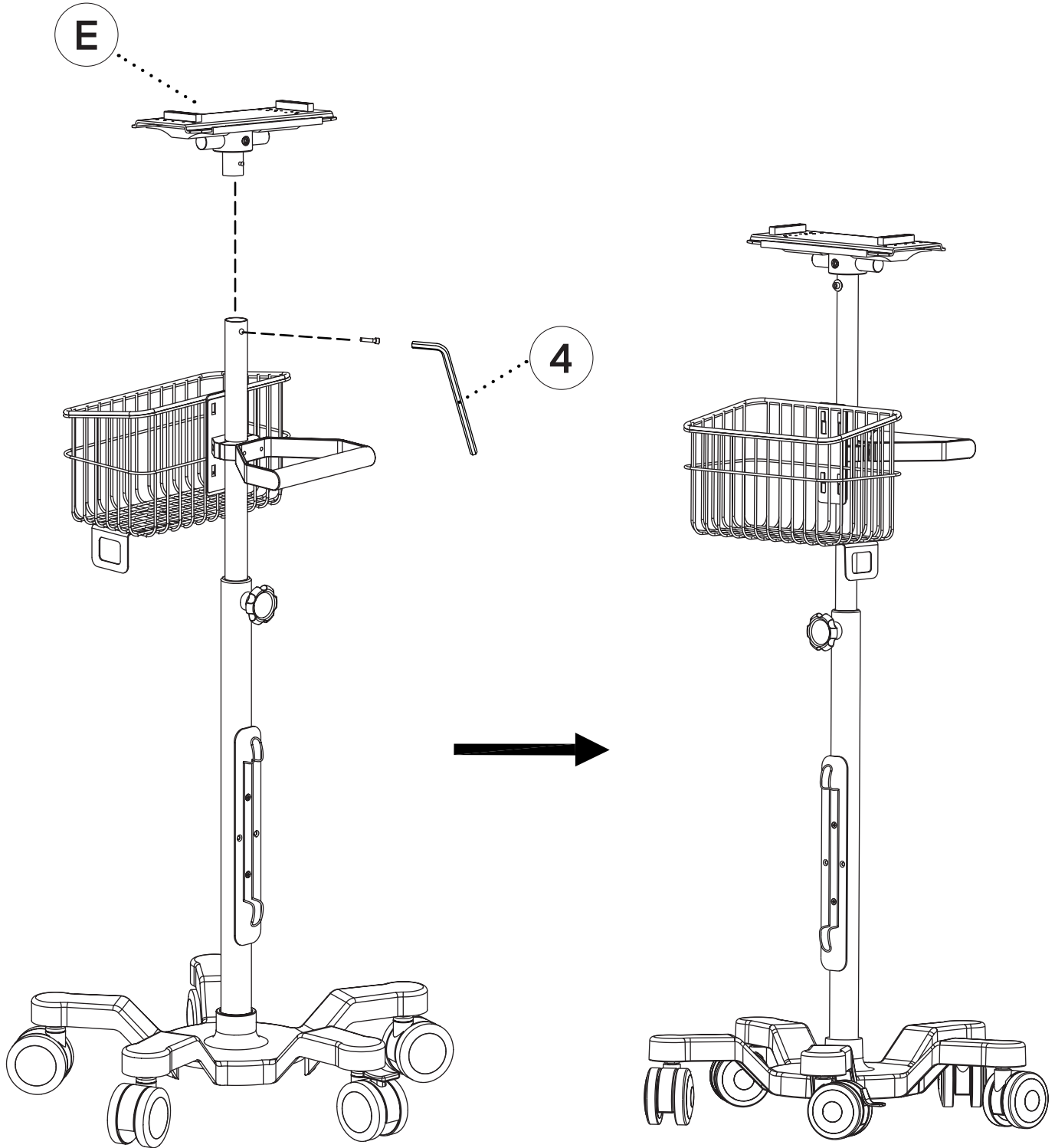

Step 5:

- A.** If you need to adjust the clamp, you can loosen the preinstalled bolts using the provided 4 mm Allen Key (4).

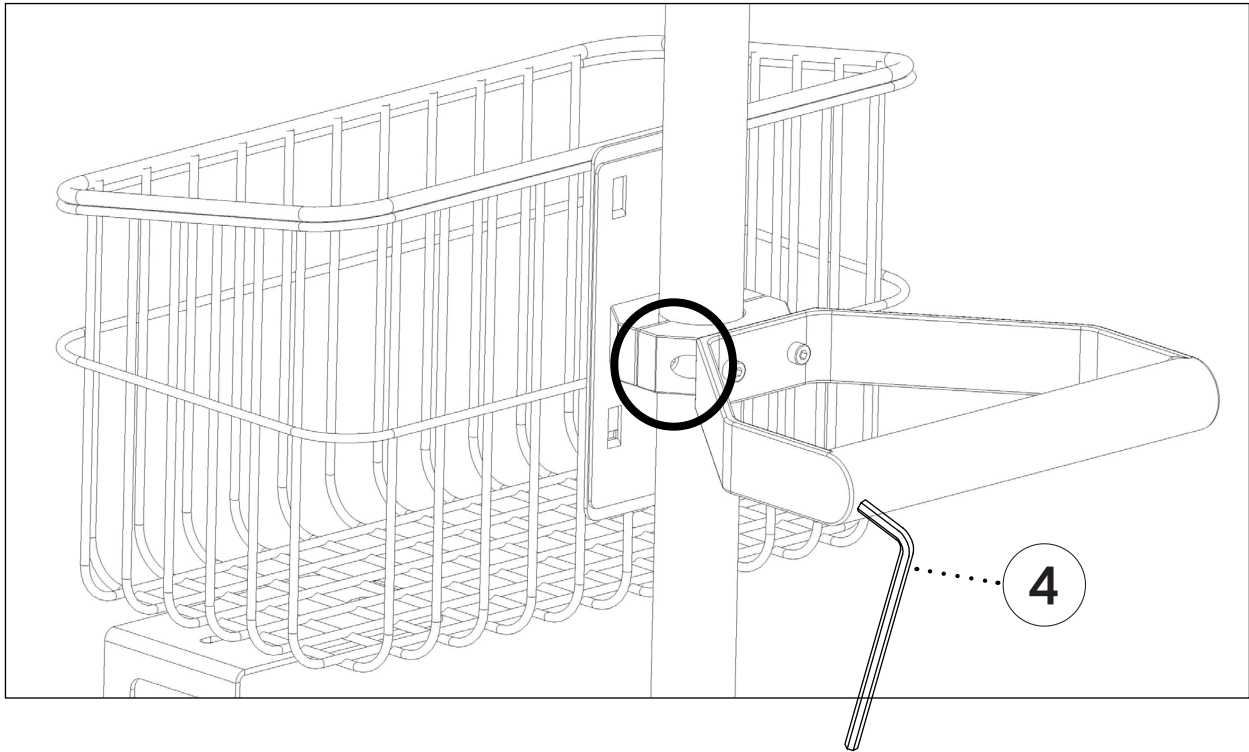

Step 6:

- A.** To enact the telescoping feature of the cart, twist the adjustment knob counterclockwise, and move the pole up or down.
- B.** To lock the position, turn the knob clockwise to secure in place.
- C.** Your Universal Mobile Cart with Edan Monitor Mounting Plate is now ready to be used.

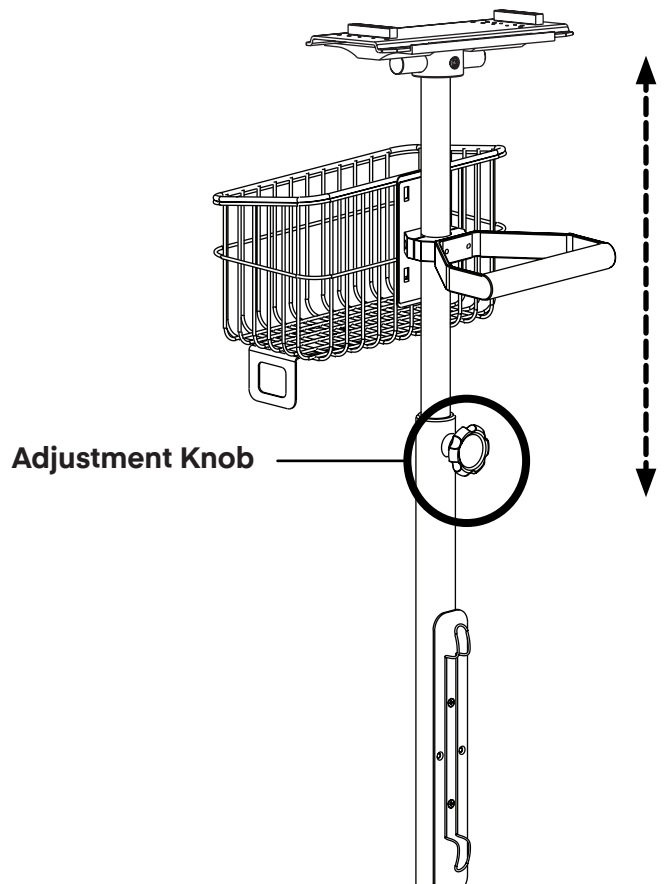

X-Series Mounting Instructions

Note:

- When the mounting plate is used for X-series machines, remove the four screws, as shown below, and the retaining strips.

X-Series: X12 / X10 / X8 / iX15 / iX12 / iX10

- For other applications, the machine can be installed directly onto the mounting plate without removing the retaining strips.

M-Series: Old models, discontinued, M80, M70, M60, M50

iM-Series: iM80, iM70, iM60, iM50

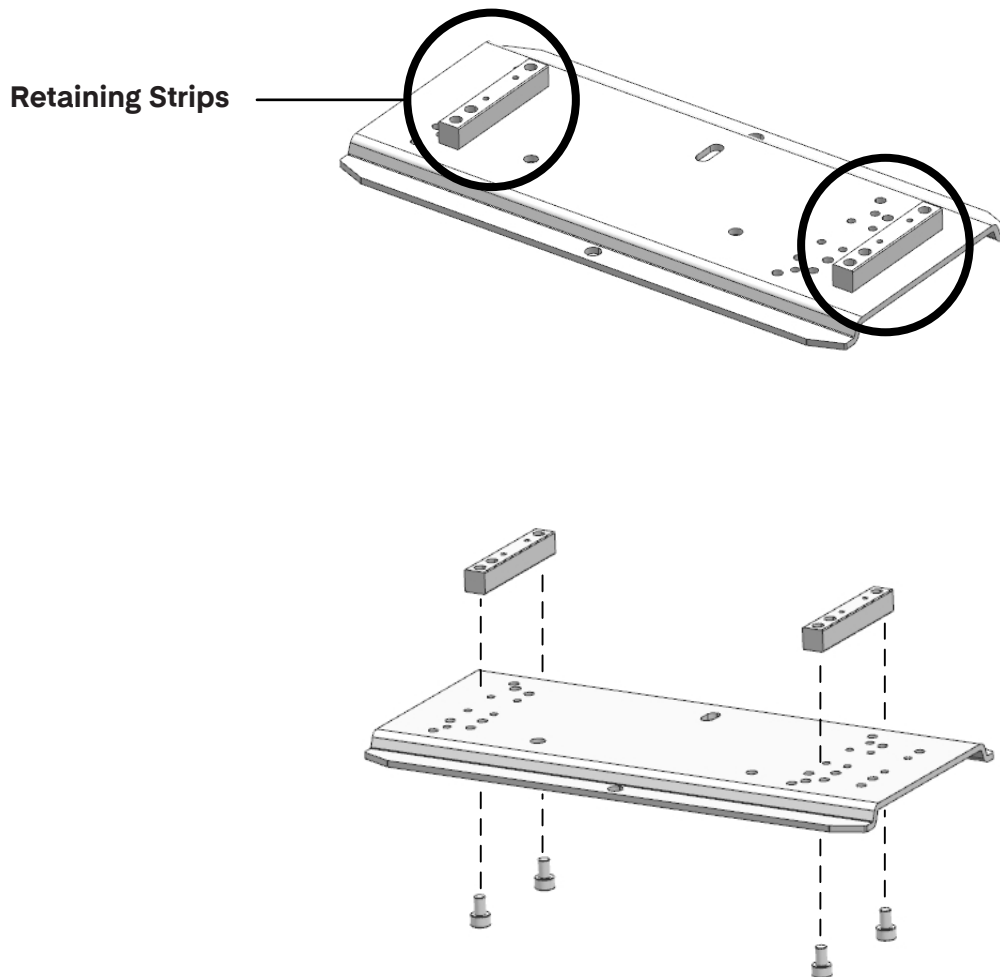

Warranty

1. Viva Comfort (the "Company" or "Tiger Companies") warrants to the purchaser that the product will be free from defects in workmanship and materials for a period of 1 year from the date of purchase. The warranty period is not extended if we repair, replace, exchange, or provide a refund for the product (as determined in our sole discretion). We may change the availability of this limited warranty at our discretion, but any changes will not be retroactive.
2. These warranties are not assignable or transferable to any other person, including, without limitation, any subsequent owner or other transferee of the product.
3. This Warranty does not apply to: (a) damage caused by misuse, tampering, abuse, neglect, or accident; (b) damage caused by improper installation, modification, or service; (c) alteration of the serial number; or (d) use that violates the instructions furnished by the Company will void this warranty.
4. The sole responsibility of the Company shall be limited to (a) the repair or replacement (in its sole discretion) of any component of the product which fails to conform to this; (b) a refund the purchase price of such product (in its sole discretion), at no cost to the purchaser for the period of the warranty, or (c) an exchange for a similar product, comparable in function and price.
5. Contact the Company directly at 1-(800)-805-1790 to obtain service under this warranty. If it becomes applicable to send a defective product to the Company, a Return Authorization Number must first be obtained from the Company. In order to obtain service under this warranty, purchaser may be required to provide the Company with the following items (a) proof of purchase, (b) photographs and or videos (of the damage, and (c) a written testimonial describing the defect.
6. Products shipped without prior Return Authorization and Return Authorization Number may not be accepted, and the Company will not be responsible for their disposition and/or cost of return to the owner.
7. The Company will not assume any responsibility for any loss or damage incurred in shipping and or delivery.
8. The product(s) must be returned within 14 calendar days of receiving the return authorization from the Company and must include the original proof of purchase for the warranty to be honored.
9. Any implied warranties that the purchaser may have are limited to the duration of the warranties described above. There are no further warranties that extend or apply beyond the face hereof, and the Company expressly disclaims and excludes any and all warranties of merchantability or fitness for a particular purpose. Some states do not allow limitations on how long an implied warranty lasts, so the above limitation may not apply to you.
10. THE REMEDIES DESCRIBED ABOVE ARE YOUR SOLE AND EXCLUSIVE REMEDIES AND THE COMPANY'S ENTIRE LIABILITY FOR ANY BREACH OF THIS LIMITED WARRANTY. OUR LIABILITY SHALL UNDER NO CIRCUMSTANCES EXCEED THE ACTUAL AMOUNT PAID BY YOU FOR THE DEFECTIVE PRODUCT, NOR SHALL WE UNDER ANY CIRCUMSTANCES BE LIABLE FOR ANY CONSEQUENTIAL, INCIDENTAL, SPECIAL OR PUNITIVE DAMAGES OR LOSSES, WHETHER DIRECT OR INDIRECT. SOME STATES DO NOT ALLOW THE EXCLUSION OR LIMITATIONS OF INCIDENTAL OR CONSEQUENTIAL DAMAGES, SO THE LIMITATION MAY NOT APPLY TO YOU.
11. This warranty gives you specific legal rights, and you may also have additional rights which vary from state to state.

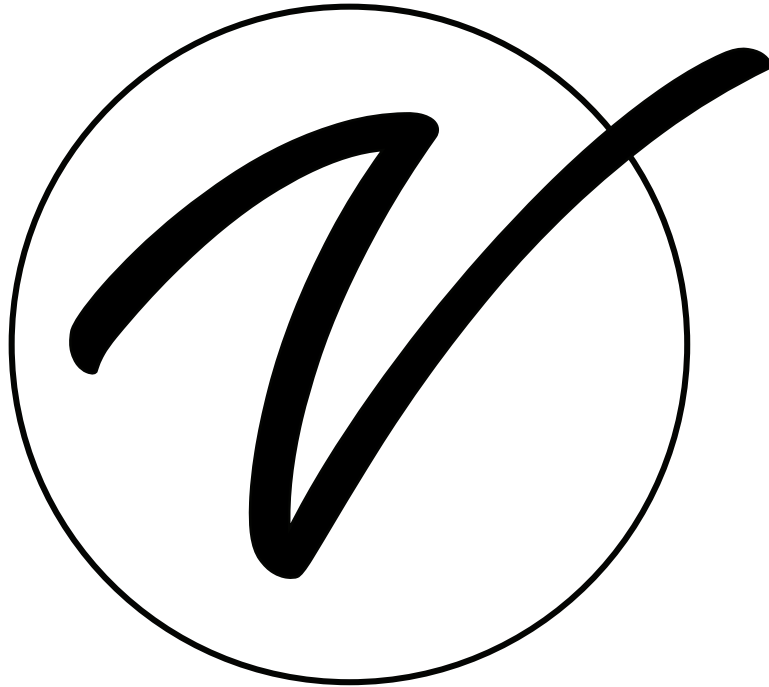

ADIME912-MP-03

© 2026 Viva Comfort

vivacomfort.com