

Viva
COMFORT

VIVA DIAGNOSTICS

OMNI SPOT VITAL SIGN
PATIENT MONITOR

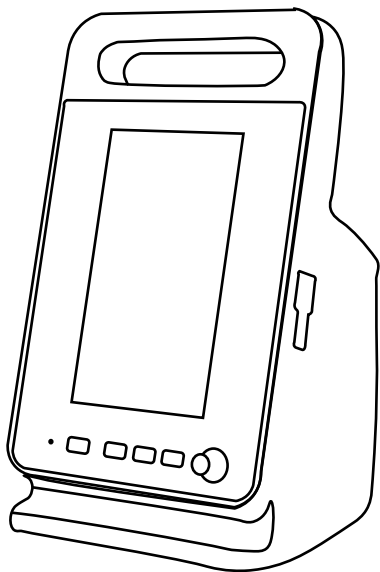

USER GUIDE

SKU: ADIME913-M-1



Thank you for your purchase.



Viva Comfort maintains a strong practice of ongoing development of products and commercial research.



We recognize that starting and maintaining a medical practice is expensive. We'll help make the process cost-effective and elegant. Additionally, our team of specialists will ensure everything you need works as efficiently as possible, so you can effectively treat your clients.

Table of Contents

| | |
|-----------|----------------------------------|
| 6 | 1 Introduction |
| 6 | 1.1 Safety Information |
| 11 | 1.2 Intended Use |
| 11 | 1.3 Contraindications |
| 12 | 1.4 Product Features |
| 13 | 1.5 Electromagnetic Interference |
| 14 | 1.6 Symbol Definition |
| 15 | 2 General Descriptions |
| 15 | 2.1 Understanding The Monitor |
| 17 | 2.2 Sensor Connection |
| 17 | 2.3 Power Supply |
| 17 | 2.4 Charging The Device |
| 18 | 2.5 Checking Functions |
| 18 | 2.6 Power Off |

Table of Contents

19 3 Settings

20 3.1 Patient Information

22 3.2 Alarm Setting

25 3.3 System Setting

26 3.4 Data Review

27 3.5 Default

28 3.6 Demo

29 3.7 Wireless Setting

31 4 Taking Measurements

31 4.1 Preparation

32 4.2 NIBP Measurement

38 4.3 SpO₂, PR, and PAI

44 5 Maintenance

44 5.1 Examination

44 5.2 Cleaning and Disinfection

Table of Contents

- 47 5.3 Troubleshooting
- 48 5.4 Warranty and Repair
- 49 **6 Specifications**
- 54 **7 Connecting Your Monitor To The Thermometer**
- 58 **Appendix A FCC Declaration**
- 60 **Appendix B Compliance Information For EMC Test**

1 Introduction:

- A.** Before using the Viva Diagnostics Omni Spot Vital Sign Patient Monitor, the user must carefully read this manual to operate the monitor correctly and achieve the specific safety standard and performance index.
- B.** This manual explains how to set up and use the monitor and introduces essential safety information related to the general use of the monitor.

Note: The monitor requires no routine calibration, safety maintenance, or in-service.

1.1 Safety Information:

WARNINGS!:

They will alert the user to potential serious outcomes, such as injury or adverse events to the patient or user.

CAUTIONS:

They will alert the user to exercise care necessary for the safe and effective use of the monitor.

NOTES: Contain important information that may be overlooked or missed.

WARNINGS!:

- Carefully read the manual before use.
- Operation of the equipment may be affected by the use of an electrosurgical unit (ESU) or high-frequency interference.
- Do not use the equipment in an MRI or CT environment.
- Do not use the equipment in an explosive, flammable, or anesthesia atmosphere.
- Do not use the equipment on the airplane.
- Do not use the equipment with a defibrillator, pacemaker, or hearing aid.
- The equipment is intended only as an adjunct in patient assessment.
- It must be used in conjunction with other methods of assessing clinical signs and symptoms.
- This equipment is not intended for use during patient transport outside the healthcare facility.
- To ensure correct sensor alignment and skin integrity, our device's maximum application and relocation time at a single site should be less than half an hour. The temperature of the SpO₂ probe should be less than 43°.
- Do not sterilize the device using autoclaving, ethylene oxide sterilizing, or immersing the device in liquid. The device is not intended for sterilization.
- Only a qualified physician can use the equipment; the patient should follow the physician's advice to use the equipment.

WARNINGS!: (Continued)

- Only use the accessories approved by our company. Other accessories may affect the equipment's performance. The accessories contain a battery, external power supply line, cuff, and SpO2 sensor.
- Avoid extremes in temperature and humidity. Do not use this device in locations subject to temperature or humidity that is too high or too low.
- Avoid storing in places that have dangerous chemicals or gas leakage.
- Follow local ordinances and recycling instructions regarding disposal or recycling of the device and device components, including batteries.
- Chemicals from a broken panel are toxic when ingested. Use caution when the monitor's display screen is broken.
- Defibrillation protection is only implemented on the ECG cable, which has the defibrillation function.
- The use of the device is restricted to one patient at a time.
- When a defibrillator is used on a patient, the device requires special protection, primarily when the discharge of a defibrillator affects the device.
- Please use the accessories approved by the manufacturer. **PACEMAKER PATIENTS:** Rate meters may continue to count the pacemaker rate during cardiac arrest or some arrhythmias. Do not rely entirely upon heart rate meter **ALARM SIGNALS**.
- To avoid the risk of leakage on the patients, the cable is isolated by high voltage, and an insulation material has been adopted. In order to improve the service life of the cable, we use high-quality cables.

WARNINGS!: (Continued)

- These materials that come into contact with the patient's skin all pass the ISO10993-5 Tests for invitro cytotoxicity and ISO10993-10 Tests for irritation and delayed-type hypersensitivity.
- Please note that changes or modifications not expressly approved by the party responsible for compliance could void the user's authority to operate the equipment.
- Stop the measurement if the device is not working or abnormal during operation. Please wait until it's normal.
- When using defibrillation, it needs to remove other non-defibrillation applied parts from patients.
- Use of this equipment adjacent to or stacked with other equipment should be avoided because it could result in improper operation. If such use is necessary, this equipment and the other equipment should be observed to verify that it's operating normally.
- Use of accessories, transducers and cables other than those specified or provided by the equipment manufacturer could result in increased electromagnetic emissions or decreased electromagnetic immunity of this equipment and result in improper operation.
- Portable RF communications equipment (including peripherals such as antenna cables and external antennas) should be used no closer than 30 cm (12 inches) to any part of the device, including cables specified by the manufacturer. Otherwise, the performance of this equipment could be degraded.
- Don't use near active HF SURGICAL EQUIPMENT and the RF-shielded room of an ME SYSTEM for magnetic resonance imaging, where the intensity of EM DISTURBANCES is high.

CAUTIONS:

- Check whether the equipment is in the correct status or not.
- Check all the lead's connections; ensure they connect well.
- Check the quantity and status of the battery.
- Ensure the safety of the patient. Take out the leads or sensors when cutting off the power supply,
- Do not drop fire goods, medals, or liquids into the equipment. If these things fall into the equipment, please cut off the power supply and stop working.
- Pull out the leads and other accessories lightly.
- If the components of this equipment need to be replaced (such as the battery, pump, etc.), only a professional can operate them.
- Rx only: "Caution: Federal law (USA) restricts this device to sale by or on the order of a licensed practitioner.

NOTES:

- The EMISSIONS characteristics of this equipment make it suitable for use in industrial areas and hospitals (CISPR 11 class A). If used in a residential environment (for which CISPR 11 class B is normally required), this equipment might not offer adequate protection for radio-frequency communication services. The user might need mitigation measures, such as relocating or reorienting the equipment.

1.2 Intended Use:

- A. The Viva Diagnostics Omni Spot Vital Sign Patient Monitor is a portable device for measuring physiological parameters, such as NIBP, SpO₂, PR, and Pulse waveform, of adult, three-year-old, and older pediatric patients in hospitals, community hospitals, and medical facilities.
- B. It is intended for spot-checking and/or continuous monitoring of patients.

1.3 Contraindications:

Active Patients:

- Intravascular dyes such as indocyanine green or methylene blue.
- Significant levels of dysfunctional hemoglobins (such as carboxyhemoglobin or methemoglobin).
- The presence of high ambient light. Shield the sensor area (with a surgical towel or direct sunlight, for example) if necessary.
- Venous pulsations may cause erroneous low readings (e.g., tricuspid valve regurgitation).
- Venous congestion may cause a reading of actual arterial oxygen saturation. Therefore, ensure proper venous outflow from the monitored site. The sensor should not be below heart level (e.g. sensor on the hand of a patient in a bed with arm dangling to the floor).
- Avoid placing the sensor on any extremity with an arterial catheter, intravascular line, or blood pressure cuff.

1.3 Contraindications: (Continued)

Active Patients:

- Exercise caution with poorly perfused patients; skin erosion and/or pressure necrosis may occur.
- Do not use the monitor when the patient is in cardiac arrest or defibrillation.

1.4 Product Features:

- Large 7" TFT display provides a clear view.
- Manual and customizable NIBP measurement modes offer flexibility for various clinical applications.
- An optional barcode scanner can speed up patient ID input.
- Optional LAN or wireless EMR connectivity options.
- The large internal memory can store up to 10,000 groups to support patient administration and effective record keeping.
- Equipped with a long life 8 hours high-capacity battery pack, Viva Diagnostics Omni Spot Vital Sign Patient Monitor can be used in any healthcare setting.
- The integrated carry handle assists with transportation and portability.

1.5 Electromagnetic Interference:

Under normal measuring, the equipment does not interfere with the surrounding people, units, and environment. While sending data, the device interferes with the surrounding people, units, and environment. If the equipment is in a high-frequency electromagnetic environment, it will harm the equipment, and the intended function will fail. During operation, you should prevent, identify, and solve the adverse electromagnetic effect. Make sure the functions of the equipment are normal.

The reasons for the interference and solutions:

- **From the RF wireless module, electromagnetic interference:**

If the interference from the RF wireless module, please replace the equipment location.

- **Direct or indirect ESD:**











Before using the equipment, make sure the user and the patient do not have direct or indirect ESD.

The damp room can alleviate problems.

- **From the radio receiver (radio or television) interference:**

Keep away from the interference source. If the above proposals cannot solve the problems, please contact the consumer service center.

1.6 Symbol Definition:

| Symbol | Definition | Symbol | Definition |
|--|---|---|---|
|  | Caution |  | Follow operating instruction |
| IP22 | The degree of protection against dust and water |  | Serial number |
|  | Waste electrical and electronic equipment |  | Storage temperature and humidity |
|  | Data of manufacture |  | Manufacturer's information |
|  | Type BF applied part |  | Quantity of the battery |
|  | European union approval |  | Authorized representative in the European community |
| ? | Unstable signal indication | | |

2 General Descriptions

2.1 Understanding The Monitor

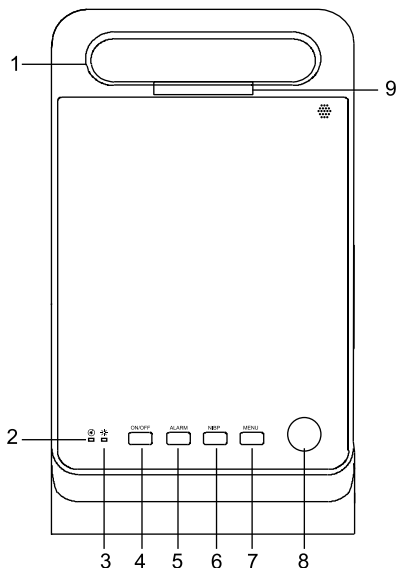

- 1. Integrated Handle**
- 2. Power Indicator Light:** Light turns on when using AC power adapter.
- 3. Indicator Light:** Light turns on when device is turned on.
- 4. Power Button:** Press and hold for 3 seconds to power on and 4 seconds to power off.
- 5. Alarm Silence Button:** Press this button to silence the audible alarm for one minute.
- 6. Shortcut Button For NIBP Measuring**
- 7. Menu Button:** Press this button to enter into the setting menu.
- 8. Rotary Knob:** Use this knob to select the menu item and modify the setup. It can be rotated clockwise or counter-clockwise and pressed like the other buttons.
- 9. Alarm Indicator Light:** Light turns on when alarm goes off.

2.1 Understanding The Monitor: (Continued)

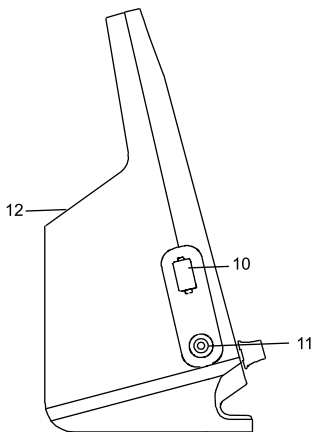

Fig.2.1-2

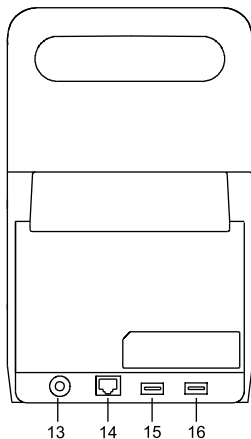

Fig.2.1-3

- 10. SpO₂ Interface:** For connecting the SpO₂ sensor
- 11. NIBP Interface:** For connecting the extended BP wires and cuff.
- 12. Storage Space:** Great for holding accessories.
- 13. Power Adapter Socket:**
- 14. Wire LAN Socket:** Use for internet application; transmit data to the computer software of the nurses station .
- 15. USB Socket:** For connecting USB flash drive; upgrade its program, and input/output data.
- 16. USB Socket:** For connecting USB flash drive; upgrade its program, and input/output data.

2.2 Sensor Connection:

SpO₂ Sensor: Insert the SpO₂ probe into the SpO₂ socket (See 10 in Figure 2.1).

NIBP Cuff: Insert the air connector of the BP cuff into the NIBP socket (See 12 in Figure 2.1).

2.3 Power Supply:

External AC Adapter: AC-input 100–240V, 50–60Hz, 0.8A Max; DC-output 9.0V, 3.0A.

Internal Battery: One piece of lithium battery, rated voltage is 7.2V, 2600mAh. If the AC power supply is applied, make sure to put the device in safe and proper place and it is convenient to power the monitor off.

2.4 Charging The Device:

Plug the power adapter into a wall outlet and insert the other end into the charging port located on the back of the device. The capacity of the battery will be displayed on the screen. When the battery reaches 100%, the battery indicator will show it is fulfilled. Unplug the power adapter after finishing charging.

- The minimum operating time of the device is 3.5 hours with a fully charged battery.
- The battery charge time from depletion to 90% charge is 2.5 hours.
- The battery charge time from depletion to 100% charge is 3 hours.

NOTE: Charge the battery every two months if the monitor is not in use for an extended period.

2.5 Checking Functions:

Main Unit: Press and hold the power button for 3 seconds to power on the device; press and hold the power button for 4 seconds to power off the device. This indicates the device is in good condition.

SpO₂ Probe: SpO₂ probe is not worn out. Rightly connect the SpO₂ probe with the device, the red light of the SpO₂ probe flashes. Open the clamp, the light keeps on. Insert the finger into the SpO₂ probe; the measurements are displayed on the screen. This indicates that the SpO₂ probe is in good condition.

BP Cuff: The BP cuff is not worn out. During the measurement, the device inflates the cuff without leakage, and the measurements are displayed on the screen. This indicates the BP cuff is in good condition.

Power Adapter: Insert the power adapter into the device's power adapter socket; the power indicator light is on in green. This indicates the adapter is in good condition.

2.6 Power Off:

After measurement, please take the sensor it off the finger and press and hold the power button to turn off the device. When the device is powered off for 30 seconds, the alarm settings and parameter data saved in it will not be lost.

3 Settings:

First Use:

Setup the following up parameters after turning on the device:

Setup for the First Use

Model: MD2000C

Language:

NIBP Unit:

Height Unit:

Weight Unit:

Date Format:

Date: 2018-07-05

Time Format:

Time: 09:28:04 am

Language:

English, French, Russian, German, Portuguese, Spanish, Italian, Norwegian, and Netherlands.

NIBP Unit : mmHg, kPa

Height Unit : cm, in

Weight Unit : kg, lb

Date Format : yyyy-MM-dd, yyyy/MM/dd, dd-MM-yyyy

Time Format : 12h, 24h

Under the measuring interface, press the menu button to enter the setting menu.

Menu

| | |
|--|---|
| <input type="button" value="Patient Information"/> | <input type="button" value="Alarm Setting"/> |
| <input type="button" value="System Setting"/> | <input type="button" value="Data Review"/> |
| <input type="button" value="Default"/> | <input type="button" value="Demo"/> |
| <input type="button" value="Maintenance"/> | <input type="button" value="Wireless Setting"/> |
| <input type="button" value="Exit"/> | |

Fig.3.2

3 Settings: (Continued)

The rotary knob acts like the cursor of the computer.

How To Set Up The Parameters?

1. Rotate the knob to choose the item.
2. Press the knob to enter the submenu.
3. Rotate the knob to choose the item, and press the knob to confirm.
4. Rotate the knob to adjust the item, and press the knob to confirm.

3.1 Patient Information:

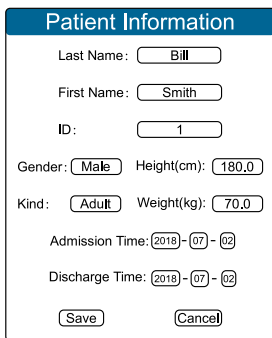

Rotate the knob to select the "Patient Information" and press the knob to enter the page below (Fig.3.3). Fill in the patient information.



The screenshot shows a form titled "Patient Information" with a blue header. The form contains the following fields and values:

| | |
|-----------------|------------|
| Last Name: | Bill |
| First Name: | Smith |
| ID: | 1 |
| Gender: | Male |
| Height(cm): | 180,0 |
| Kind: | Adult |
| Weight(kg): | 70,0 |
| Admission Time: | 2018-07-02 |
| Discharge Time: | 2018-07-02 |
| [Save] [Cancel] | |

Fig.3.3

1. Popup the keyboard when inputting the last name, first name, and ID. Rotate the knob to input them.
2. Rotate the knob to the shift icon (red cycle 1/ Fig. 3.4), then press to change case, rotate the knob to the delete icon (red cycle 2/ Fig. 3.4), then press to delete letter or number, rotate the knob to the symbol icon (red cycle 3/ Fig. 3.4), then press the symbol keyboard.
3. Select the patient type; adult  or child .

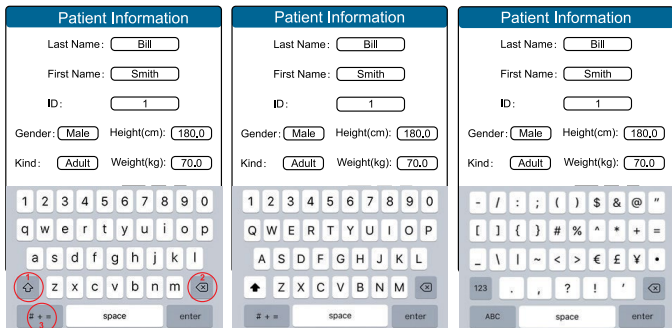

Fig.3.4

3.2 Alarm Setting:

1. Rotate the knob to select the “Alarm Setting” and press the knob.
2. Then, you need to enter the password “2222” in the popup box (Fig. 3.5) to enter the submenu (Fig.3.6).

NOTE: Password input is required for Alarm Setting each time.

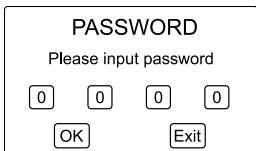

Fig.3.5

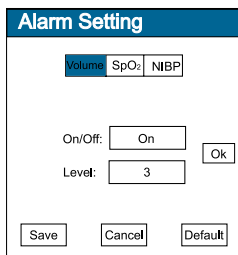

Fig.3.6

How To Input Passwords?

1. Rotate the knob to choose one of the digits.
2. Press the knob to confirm.
3. Rotate the knob to adjust the number to be 2.
4. Press the knob to confirm.
5. Repeat step one. Press the knob on “OK” to enter alarm setting interface (Fig.3.6) or on “Exit” to go back to the main menu (Fig.3.2).

Under the Alarm Setting Interface:

1. Rotate the knob to choose Volume, SpO₂, or NIBP, and press the knob to confirm. Then control the knob to set the values of the selected item.
2. Press the knob on "OK" to confirm your settings.
3. Rotate the knob to choose another item (repeat step 1), or press the knob on save, cancel, or default; you will save, cancel or restore to default your settings.

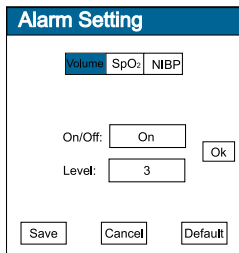

Fig.3.6

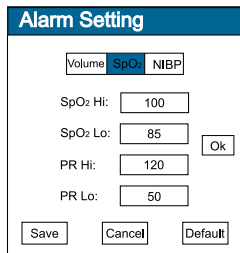

Fig.3.7

Volume Setting:

- On/Off : Turn on or off the alarm
- Level : Adjust the volume from 1 to 5
- Default setting: Volume on Level 3

SpO₂/PR Limits Setting:

- SpO₂:
High Limit Range:
86 ~100%
Low limit range:
85 ~99%
- PR:
High limit range:
32 ~250bpm
Low limit range:
30 ~248bpm
- Default setting:
SpO₂ Hi 100 / Lo 85
PR Hi 120 / Lo 50

NIBP Limits Setting:

- SYS:
High limit range : 16 ~ 295mmHg
Low limit range : 15 ~ 294mmHg
- DIA:
High Limit Range: 11 ~ 285mmHg
Low Limit Range: 10 ~ 284mmHg
- Unit: mmHg / kPa
- Default Setting:
SYS Hi 140 / SYS Lo 90
DIA Hi 90 / DIA Lo 60
Unit: mmHg

* The low limit should be less than the high limit.

The screenshot shows a menu titled "Alarm Setting" with a blue header. Below the header, there are three tabs: "Volume", "SpO₂", and "NIBP", with "NIBP" being the active tab. The settings are as follows:

| | | | |
|---------|------|---------|----|
| SYS Hi: | 140 | SYS Lo: | 90 |
| DIA Hi: | 90 | DIA Lo: | 60 |
| Unit: | mmHg | | |

At the bottom of the menu, there are three buttons: "Save", "Cancel", and "Default".

Fig.3.8

3.3 System Setting:

1. Rotate the knob to select "System Setting" and press the knob to enter the submenu.

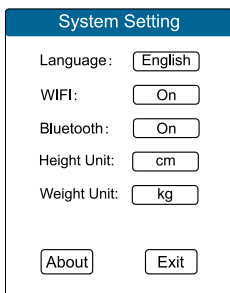

Fig.3.9

Language: English, French, Russian, German, Portuguese, Spanish, Italian, Chinese

Wifi: ON/OFF

Bluetooth: ON/OFF

Height Unit: cm/in

Weight Unit: kg/lb

About: The Software Information

Default Setting:

Language: English

Wifi: On **Bluetooth:** On

Height Unit: cm

Weight Unit: kg

3.4 Data Review:

1. A "User Table" will show you all users' information. Press the knob on "ID" at the bottom of the screen and rotate the knob; you can select the ID.
2. Then press the knob on "Data Review" or "Graph Review" to check the measurement data of this ID.

| USER TABLE | | | | | |
|------------|----|-----------|------------|--------|-------|
| Item | ID | Last Name | First Name | Gender | Kind |
| 1 | 2 | Lily | Smith | Female | Adult |
| 2 | 36 | Tom | Brown | Male | Adult |

Last Name: Lily First Name: Smith Current/Total: 2/2
 Gender: Female Kind: Adult
 Height(cm): 170.0 Weight(B): 45.0
 Admission Time: 20181120 Discharge Time: 20190110

ID:

Fig.3.10-User Table

| Data Review | | | | | | |
|-------------|-----|------------------|----|-----|-----|--|
| | me | SpO ₂ | Pr | Sys | Dis | |
| 5 | :15 | 98 | 68 | 101 | 67 | |
| 2019 | :14 | 98 | 68 | 100 | 68 | |
| 3 | :13 | 98 | 67 | 103 | 69 | |
| 2019 | :12 | 99 | 67 | 99 | 68 | |
| 2019 | :11 | 98 | 67 | 100 | 69 | |

Gender: First Name: Smith Current/Total: 2/2
 Kind: Adult
 Adm: 0 Weight(B): 45.0
 20190110 Discharge Time: 20190110

Fig.3.11-Data Review

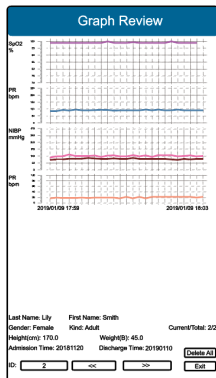

Fig.3.12-Graph Review

3. Rotate the knob to the arrow symbols « » at the bottom of the "Data Review" and "Graph Review" and press the knob to review the records page by page.
4. Rotate the knob to "Delete All" and press the knob to delete data. The device can record the alarming parameter marked in red.

3.4 Data Review: (Continued)

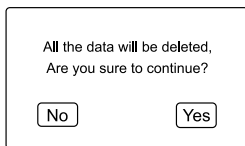

Fig.3.13

CAUTION!

Be aware that you cannot retrieve data once it has been deleted.

3.5 Default

CAUTION!

When setting your device to factory default, all settings will be reset.

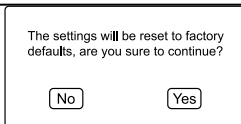

Fig.3.14

3.6 Demo:

1. Rotate the knob on demo mode, and press the knob to enter the demo screen.
2. Under the demo interface, press the knob to return to the menu screen.

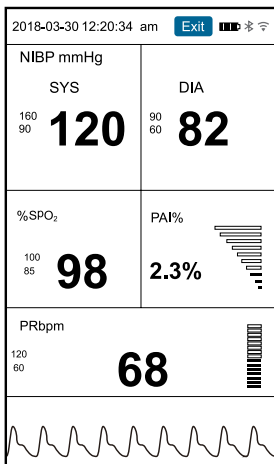
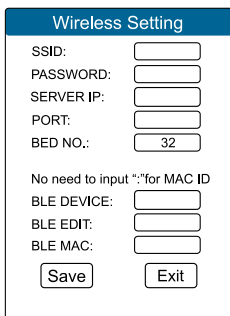

Fig.3.15

3.7 Wireless Setting:

A wireless setting is required for a Wi-Fi or Bluetooth connection. The device's Bluetooth functionality allows it to receive measurement data from other devices. Its Wi-Fi functionality allows it to send measurement data to software installed on the computer.



Wireless Setting

SSID:

PASSWORD:

SERVER IP:

PORT:

BED NO.:

No need to input ":" for MAC ID

BLE DEVICE:

BLE EDIT:

BLE MAC:

Fig.3.16

Wifi Network: Input the internet information to connect it.

- SSID and password of the wireless router
- IP address of the server
- Port number

Bluetooth Connection: Input the information of the device to be connected and save it. The monitor begins to search for the device and connect it.

- BLE DEVICE: Product name
- BLE EDIT: MAC address of the device
- BLE MAC: Choose historical MAC address

3.7 Wireless Setting: (Continued)

NOTES:

- The transmission distance of Bluetooth should be within 3 meters.
- Remove objects, especially large metal obstructions that obstruct the straight propagation of light and block the signal transmission.
- Before using, install antivirus software and firewalls on a PC (Personal Computer).
- Please set a password for your PC (Personal Computer) to prevent data from being stolen.

4 Taking Measurements:

4.1 Preparation:

Before measuring, slightly connect the sensor.

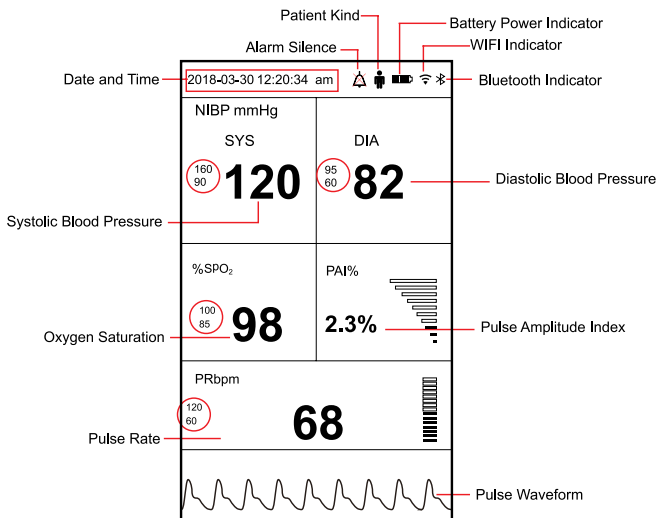

Fig.4.1

NOTES:

- Data in the red circle are the high and low limits of the parameter.
- It shows dashes "--" when no measurement is displayed.
- If the screen displays "?", the signal is unstable; please keep your hands still and retry.

4.1 Preparation: (Continued)

Date and Time Setting:

1. On the main screen, rotate the knob to the "Date and Time", then press the knob to enter the time setting screen.
2. Under the time setting screen, rotate the knob to the "Time Setup" to adjust the date and time.

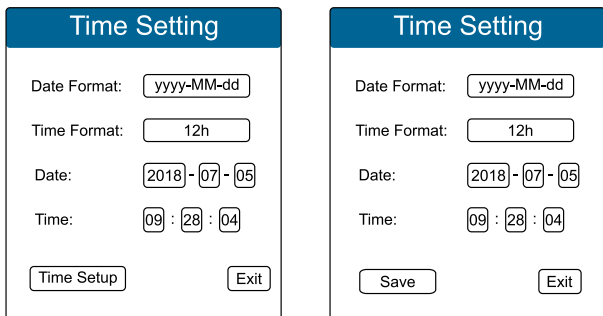

Fig.4.2

4.2 NIBP Measurement:

Measurement Principle:

This device is intended for noninvasively measuring an adult or child's systolic and diastolic blood pressure using the oscillometric method.

NIBP Setting:

On the main screen, rotate the knob on the NIBP, press the knob to enter the NIBP setting screen. You can set the high and low limits and the unit of the NIBP.

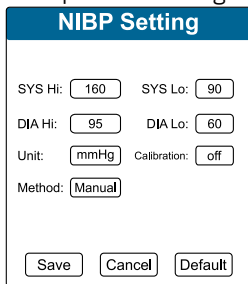

Fig.4.3

4.2 NIBP Measurement: (Continued)

NOTES:

- Remember to SAVE the settings, or you can CANCEL the settings.
- Press "Default" if you want to reset all the settings to the factory default.
- Measuring Method: You can set it to Manual or Auto between every 1/3/5/10/20/30/60 minute(s).

Measuring:

1. Apply The Blood Pressure Cuff

- Connect the cuff to the monitor.
- Apply the cuff to the patient's arm (Fig.4.4.)
- Please sit up straight and stay relaxed with your palm facing up.
- Make the cuff level with your heart.

2. Press The Shortcut Button (NIBP)

- The cuff is first inflated.
- It will stop when it reaches the inflation pressure,
- and then the pressure slowly falls away.
- Read the results: Systolic & Diastolic Blood Pressure in the display:

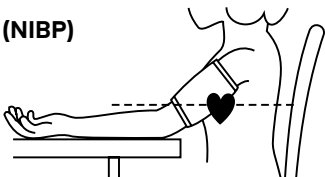

Fig. 4.4

| | |
|------------------------|-----------|
| 2018-03-30 12:20:34 am | |
| 🔔 🧑 📶 🔌 | |
| NIBP mmHg | |
| SYS | DIA |
| 160 90 | 95 60 |
| 120 | 82 |

Fig. 4.5

4.2 NIBP Measurement: (Continued)

WARNINGS!:

- Before starting a measurement, verify that you have selected a setting appropriate for your patient.
- Do not apply the cuff to a limb with an intravenous infusion or catheter. This could cause tissue damage around the catheter when the infusion is slowed or blocked during cuff inflation.
- Make sure that the air conduit connecting the blood pressure cuff and the monitor is neither blocked nor tangled.
- Plug in the air hose and switch on the system.
- Too frequent measurements can cause injury to the patient due to blood flow interference.
- Do not apply the cuff over a wound, which can cause further injury.
- Don't apply the cuff and its pressurization on the arm on the side of a mastectomy.
- Pressurization of the cuff can temporarily cause the function of the simultaneously used monitoring device on the same limb to be lost.
- Check the operation of the Automated sphygmomanometer does not result in prolonged impairment of the patient's circulation of the blood.
- Any blood pressure reading can be affected by the measurement site, the patient's position (standing, sitting, lying down), exercise, or physiologic condition.
- The performance of the automated sphygmomanometer can be affected by extremes of temperature, **34** humidity, and altitude.

4.2 NIBP Measurement: (Continued)

NOTES:

- Ensure that the cuff is completely deflated.
- The rated range of cuff pressure is 0mmHg~280mmHg.
- Apply the appropriate size cuff to the patient, and make sure that the symbol " Φ " is over the appropriate artery.
- Ensure that the cuff is not wrapped too tightly around the limb. Excessive tightness may cause discoloration and eventual ischemia of the extremities.
- The width of the cuff should be either 40% of the limb circumference or 2/3 of the upper arm length.
- The inflatable part of the cuff should be long enough to encircle 50~80% of the limb.
- The wrong size of the cuff can cause erroneous readings. If the cuff size is in question, then use a larger cuff.
- Make sure that the cuff edge falls within the range of mark <->. If it does not, use a larger or smaller cuff that fits better.
- Connect the cuff to the air hose. The limb chosen for the measurement should be placed at the same level as the patient's heart. If this is impossible, you should apply the following corrections to the measured values
- The cuff placed higher than the heart level adds 0.9 mmHg (0.10kPa) for each inch of difference or deducts 0.9 mmHg (0.10kPa) if placed lower than the heart level.

4.2 NIBP Measurement: (Continued)

WARNINGS!:

- If any abnormality is observed, stop the blood pressure measurements.
- If you suspect the value's accuracy, please adopt another method to check further.
- If the liquid splashes on the device or accessories, especially liquid entering into the device, please connect the local service center.
- Inaccurate measurements may result from such causes:
 - a.** Limb's twitch and tremble will cause inaccuracy or delay in the cycling of measurement; serious tremble will lead to failure of measurement.
 - b.** Placing the cuff too loosely or tightly on the patient.
 - c.** Leaky cuff or hose.
 - d.** Insure the NIBP and pulse rate within the range of this monitor.
 - e.** Excessive patient motion will cause inaccuracy. Patient should be relaxed and avoid movement.
 - f.** Arrhythmia leads to irregular heart beat.
 - g.** Use the artificial heart-lung machine.
 - h.** The patient is in shock or at a low temperature.
- To obtain accurate routine resting BLOOD PRESSURE measurements for the condition hypertension, including:

4.2 NIBP Measurement: (Continued)

WARNINGS!:

- a.** Adjustment of the pressure reduction rate, if applicable.
- b.** Patient position in normal use, including comfortably seated, legs uncrossed, feet flat on the floor, back and arm supported, and the middle of the cuff at the level of the heart's right atrium.
- c.** A recommendation is that the patient should relax as much as possible and not talk during the measurement procedure.
- d.** A recommendation that 5 min should elapse before the first reading is taken.
- e.** Operator position in normal use.

Pressure Safety Protection:

- Automatic deflation will be activated when the cuff pressure exceeds 280 mmHg under the adult mode.
- Automatic deflation will be activated when the continuous inflation last more than 30 seconds.
- If there is no value when measurement time exceeds 120 seconds under the adult mode, the measurement will be canceled.
- You can press the START (NIBP) button to cancel the NIBP measurement when necessary.

4.3 SpO₂, PR and PAI:

What Is SpO₂ Monitoring?:

SpO₂ plethysmogram measurement is employed to determine the oxygen saturation of hemoglobin in the arterial blood. If, for example, 97% of hemoglobin molecules in the red blood cells of the arterial blood combine with oxygen, then the blood has a SpO₂ oxygen saturation of 97%.

The SpO₂ numeric on the monitor will read 97%. The SpO₂ numeric shows the percentage of hemoglobin molecules that have combined with oxygen molecules to form oxyhemoglobin. The SpO₂/PLETH parameter can also provide a pulse rate signal and a plethysmogram wave.

SpO₂ Setting?

On the main screen, rotate the knob on the SpO₂ and press the knob to enter the SpO₂ setting screen. You can set the high & low limits and the unit of the SpO₂.

NOTES:

- Remember to SAVE the settings, or you can cancel them.
- Press "Default"; all settings will be reset to factory defaults; please be careful.

The screenshot shows a screen titled "SpO₂ Setting" with a blue header. Below the header, there are four rows of settings, each with a label and a numeric input field:

| | |
|----------------------|----------------------------------|
| SpO ₂ Hi: | <input type="text" value="100"/> |
| SpO ₂ Lo: | <input type="text" value="85"/> |
| PR Hi: | <input type="text" value="120"/> |
| PR Lo: | <input type="text" value="60"/> |

At the bottom of the screen, there are three buttons: "Save", "Cancel", and "Default".

4.3 SpO₂, PR and PAI: (Continued)

Measurement Principle:

The principle of the oximeter is as follows: A mathematical formula is established using Lambert-Beer Law according to Spectrum Absorption Characteristics of Reductive Hemoglobin (RHb) and Oxyhemoglobin (HbO₂) in the glow and near-infrared zones. Operation principle of the instrument: Photoelectric Oxyhemoglobin Inspection Technology is adopted by Capacity Pulse Scanning and Recording Technology so that two beams of different wavelengths of light (660nm glow and 905nm near-infrared light) can be focused onto a human nail tip through a clamping finger-type sensor. A measured signal obtained by a photosensitive element will be shown on the oximeter's display through the process in electronic circuits and microprocessors.

Measuring:

- 1. Power On The Device**
- 2. Connect The Sensor To The Device**

Place the measured finger into the probe, as shown in Fig.4.7.

Before starting a measurement, verify that you have selected a suitable size sensor for the patient.

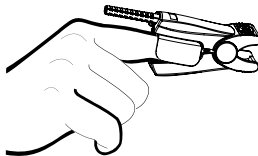

Fig.4.7

4.3 SpO₂, PR and PAI: (Continued)

3. Read The Values-SpO₂, PR and PAI on the screen.

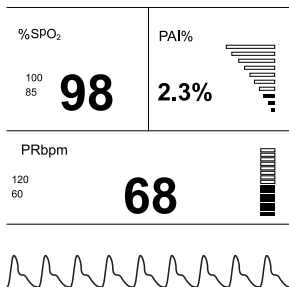

Fig.4.8

Inaccurate Measurements May Be Caused By:

- Significant levels of dysfunctional hemoglobin (such as carbonyl-hemoglobin or methemoglobin);
- Intravascular dyes such as indocyanine green or methylene blue;
- High ambient light. Shield the sensor area if necessary;
- Excessive patient movement;
- High-frequency electrosurgical interference and defibrillators;
- Venous pulsations;
- Placement of a sensor on an extremity with a blood pressure cuff, arterial catheter, or intravascular line;

4.3 SpO₂, PR and PAI: (Continued)

- The patient has hypotension, severe vasoconstriction, severe anemia, or hypothermia;
- The patient is in cardiac arrest or is in shock;
- Fingernail polish or false fingernails;
- Weak pulse quality (low perfusion);
- Low hemoglobin.

NOTES:

1. The pulse oximeter equipment is calibrated to display functional oxygen saturation.
2. Pulse oximeter monitor, the pulse oximeter probe and probe cable extender have been validated and tested for compliance with this international standard.
3. Please use the probe and cable provided by our company.
4. Please verify the compatibility of the monitor, probe, and cable before use; otherwise, patient injury can occur.
5. All the waveforms have been uniformed.
6. Functional tester cannot be used to assess the accuracy of a pulse oximeter probe or a pulse oximeter monitor.
7. Alarm condition without delay, alarm signal delay, data averaging, and other signal processing do not affect SpO₂ and PR.

4.3 SpO₂, PR and PAI: (Continued)

Probe LED Specifications:

| | Wavelength | Radiant Power |
|-----|------------|---------------|
| RED | 660±3nm | .2mw |
| IR | 905±10nm | 2.4mw |

Equipment Data Update Period:

As shown in the following figure, the data update period of slower average is 8s.

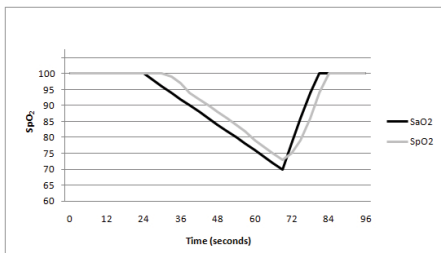

Fig.4.9

4.3 SpO₂, PR and PAI: (Continued)

Clinical Study Summary:

The following details are provided to disclose the actual performance observed in the clinical validation study of healthy adult volunteers. The ARMS value analysis statement and Bland-Altman plot of data are shown as follows:

ARMS Value Analysis Statement

| Item | 70--100 | 90--100 | 80--<90 | 70--<80 | 70--<90 |
|-------|---------|---------|---------|---------|---------|
| # pts | 247 | 80 | 85 | 82 | 167.00 |
| Bias | 1.20 | 1.60 | 1.27 | 0.72 | 1.02 |
| ARMS | 2.00 | 2.03 | 2.06 | 1.92 | 2.00 |

Bland-Altman Plot Graphic

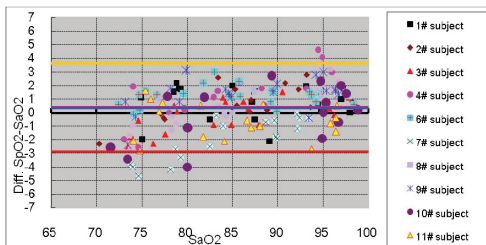

5 Maintenance

5.1 Examination

Before using the device, please check:

- Whether the device has mechanic damage or not
- All the cables and accessories
- The device functions

Do not use it when the device is damaged. Please get in touch with the local customer service center. The device needs to be repaired by professional personnel.

5.2 Cleaning and Disinfection

Customers should be responsible for periodically maintaining the device and its accessories. Disconnect the power line to the device before cleaning and inspecting.

Main Unit:

Cleaning: Use a soft cloth moistened with mild detergent to wipe the device surface.

Disinfection: Dampen a cloth with a commercial, nonabrasive cleaner to wipe the tip, bottom, and front surfaces lightly after each use.

The following cleaning agents can be used:

- Ammonia (diluted), Glutaraldehyde, Sodium hypochlorite bleach (diluted), Mildness suds (diluted).

Clean and disinfect the device after each use.

Wipe the device with a dry cloth after cleaning and disinfection.

5.2 Cleaning and Disinfection (Continued)

WARNINGS!:

- Do not use strong solvents, such as acetone.
- Do not sterilize the device using autoclaving or ethylene oxide sterilizing.
- Before using the detergent, please follow the manufacturer's instructions to dilute the detergent.
- Do not use materials that can cause wear, such as steel wool and silver polishing agents.
- Do not spray water or cleaning agents over the product, nor allow any liquid to flow into the power switch, connector, or other intakes.
- Do not leave any detergent on the surface of the device.

Blood Pressure Cuff:

Cleaning: Wipe the cuff with a soft, moist cloth (water-based) after each use.

Disinfection: After each use, wipe the cuff's surface with a soft cloth dampened with a small amount of 3% hydrogen peroxide or 70% isopropyl alcohol.

Allow the cuff to dry naturally at room temperature. The cuff must be cleaned and disinfected before use between different users.

5.2 Cleaning and Disinfection (Continued)

WARNINGS!:

- Do not squeeze the hose of the cuff.
- Do not allow liquid to enter the connector socket.
- Do not wipe the inner part of the connector socket.
- Do not soak the cuff in water.
- Do not use petrol, thinners, or similar solvents.
- The cuff contains a sensitive air-tight bubble. Handle this carefully and avoid all types of straining through twisting or buckling.

SpO₂ Probe:

Cleaning: Moisten a soft cloth or gauze with alcohol and use it to wipe the surface of the sensor, and then use a clean cloth to dry it.

Disinfection: The sensor can be disinfected with 3% hydrogen peroxide or 70% isopropyl alcohol.

The same method can be used to clean and disinfect the light source, photodetector, and cable.

5.2 Cleaning and Disinfection (Continued)

WARNINGS!:

- Disconnect the AC power before cleaning the monitor or sensor.
- Do not immerse the connector into the liquid.
- Do not immerse the sensor entirely in water, solvents, or cleaning solutions because the sensor and connector are not waterproof.
- Do not sterilize SpO₂ sensors by irradiation, steam, or ethylene oxide.
- Do not soak the sensor in the detergent liquid; if any abnormality of the sensor or cable is detected, stop using it immediately.

5.3 Troubleshooting

- No display after power turned on. Check the power connections and the power adapter.
- No SpO₂ wave and pulse rate display when monitoring. Check the probe connection and the finger temperature.
- Cuff inflation is lacking when measuring blood pressure. If the cuff is too loose or leaks, check the connections of the tube.
- When measuring the BP, inflation is unfinished but begins to deflate.
 1. Check the battery quantity. Please replace the battery if the battery quantity is less than 30%.
 2. If Step 1 doesn't work, please check whether the BP cable is pressed.

5.4 Warranty and Repair

1. Viva Diagnostics (the "Company" or "Tiger Companies") warrants to the purchaser that the product will be free from defects in workmanship and materials for a period of 3 years from the date of purchase. The warranty period is not extended if we repair, replace, exchange, or provide a refund for the product (as determined in our sole discretion). We may change the availability of this limited warranty at our discretion, but any changes will not be retroactive.
2. These warranties are not assignable or transferable to any other person, including, without limitation, any subsequent owner or other transferee of the product.
3. This Warranty does not apply to: (a) damage caused by misuse, tampering, abuse, neglect, or accident; (b) damage caused by improper installation, modification, or service; (c) alteration of the serial number; or (d) use that violates the instructions furnished by the Company will void this warranty.
4. The sole responsibility of the Company shall be limited to (a) the repair or replacement (in its sole discretion) of any component of the product which fails to conform to this; (b) a refund the purchase price of such product (in its sole discretion), at no cost to the purchaser for the period of the warranty, or (c) an exchange for a similar product, comparable in function and price.
5. Contact the Company directly at 1-(800)-805-1790 to obtain service under this warranty. If it becomes applicable to send a defective product to the Company, a Return Authorization Number must first be obtained from the Company. In order to obtain service under this warranty, purchaser may be required to provide the Company with the following items (a) proof of purchase, (b) photographs and/or videos (of the damage, and (c) a written testimonial describing the defect.
6. Products shipped without prior Return Authorization and Return Authorization Number may not be accepted, and the Company will not be responsible for their disposition and/or cost of return to the owner.
7. The Company will not assume any responsibility for any loss or damage incurred in shipping and or delivery.
8. The product(s) must be returned within 14 calendar days of receiving the return authorization from the Company and must include the original proof of purchase for the warranty to be honored.
9. Any implied warranties that the purchaser may have are limited to the duration of the warranties described above. There are no further warranties that extend or apply beyond the face hereof, and the Company expressly disclaims and excludes any and all warranties of merchantability or fitness for a particular purpose. Some states do not allow limitations on how long an implied warranty lasts, so the above limitation may not apply to you.
10. THE REMEDIES DESCRIBED ABOVE ARE YOUR SOLE AND EXCLUSIVE REMEDIES AND THE COMPANY'S ENTIRE LIABILITY FOR ANY BREACH OF THIS LIMITED WARRANTY. OUR LIABILITY SHALL UNDER NO CIRCUMSTANCES EXCEED THE ACTUAL AMOUNT PAID BY YOU FOR THE DEFECTIVE PRODUCT, NOR SHALL WE UNDER ANY CIRCUMSTANCES BE LIABLE FOR ANY CONSEQUENTIAL, INCIDENTAL, SPECIAL OR PUNITIVE DAMAGES OR LOSSES, WHETHER DIRECT OR INDIRECT. SOME STATES DO NOT ALLOW THE EXCLUSION OR LIMITATIONS OF INCIDENTAL OR CONSEQUENTIAL DAMAGES, SO THE LIMITATION MAY NOT APPLY TO YOU.
11. This warranty gives you specific legal rights, and you may also have additional rights which vary from state to state.

5.4 Warranty and Repair (Continued)

Storage and Transportation:

Storage: Temperature: $-4^{\circ}\text{F} \sim 131^{\circ}\text{F} (-20^{\circ}\text{C} \sim 55^{\circ}\text{C})$,

Humidity: $\leq 93\%$

Transportation: Transportation by road, rail or aviation after properly insured and packaged.

6 Specifications

NOTES:

- Specifications may be changed without prior notice
- The circuit diagrams, the list of components, the illustration of diagrams, and the detailed calibration rules are provided exclusively to professional personnel authorized by our company.
- The illustrations used in this manual may differ slightly from the appearance of the actual device.
- The maximum application time for each type of probe at a single site is four hours.
- The equipment has been calibrated; users do not have to calibrate. To ensure the accuracy of the probe, please change the probe once a year. Make sure that the type of probe is the one specified.
- The equipment needs 4 seconds from startup to providing essential performance.

6 Specifications (Continued)

Display:

The screen dimension: 7inch

The screen resolution: 800×480

The device dimension: 292mm ×168mm × 148mm (±5mm)

Displayed parameters: Patient information, NIBP (systolic and diastolic), %SpO₂, PR, PAI and PR waveform.

NIBP:

Adult:

Measuring range: Systolic Blood Pressure: 60mmHg ~ 255mmHg

Diastolic Blood Pressure: 30mmHg ~ 195mmHg

Pediatric:

Measuring Range: Systolic Blood Pressure: 60mmHg ~ 215mmHg

Diastolic Blood Pressure: 30mmHg ~ 195mmHg

Maximum Standard Deviation: 6 mmHg

Static Pressure Measurement Range: 20~280mmHg

Resolution: 1mmHg

Maximum Static Pressure Error: ±3mmHg

Measuring Mode: Manual/Auto (1 minutes, 3 minutes, 5 minutes, 10 minutes, 20 minutes, 30 minutes, 60 minutes)

6 Specifications (Continued)

SpO₂:

Measurement Range: 70~100%

Resolution: 1%

Accuracy: ±2%

PR:

Display Range: 30bpm~250bpm

Measurement range: 30bpm~250bpm

Resolution: 1bpm

Accuracy: ±2bpm or ±2% (Choose Larger)

PAI:

Measurement Range: 0.1%~20%

Resolution: 0.1%

Alarm Level:

| | |
|------------------|-----------------------------------|
| High (Level 1)S | pO ₂ exceeds the limit |
| Medium (Level 2) | BP exceeds the limit |
| | PR exceeds the limit |
| | TEMP exceeds the limit |
| | Systolic exceeds the limit |
| | Diastolic exceeds the limit |
| | The battery is less than 5% |
| Low (Level 3) | SpO ₂ probe off |
| | No finger |
| | Error measurement of BP |

6 Specifications (Continued)

Environment Requirements:

Operation Temperature: 33.8°F~104°F (5°C~40°C)

Storage / Transport Temperature: -4°F ~+ 131°F
(-20°C~+55°C)

Ambient Humidity: ≤80% no condensation in operation;
≤93% no condensation in storage/transport

Atmosphere pressure: 86kPa~106kPa

Power Supply:

DC7.2V/2600mAh, one rechargeable lithium battery

Operating Time: 24 hours continuous working

Power Adapter: LXCP30-009B; Output: 9V DC, 3A

Total System Response Time:

The total system response time is 4s.

Fuse:

3A/32V

Classification:

- According to the type of protection against electric shock: internal powered equipment
- According to the degree of protection against electric shock: type BF applied part
- According to the degree of protection against dust and water: IP22
- According to the mode of operation: continuous operation

6 Specifications (Continued)

Applied Part:

1. SpO₂ probe
2. NIBP Cuff

NOTE: All the applied parts comply with the biological compatibility standard.

List of Accessories:

| Accessories | Model | Type | Quantity |
|------------------------|---------------|--|----------|
| SpO ₂ Probe | M-50E013CS099 | pin (DB9), 0.9m1 | piece |
| NIBP Cuff For Adult | RNC0001A-013B | 27CM-35CM1 | piece |
| NIBP Cuff For Child | CM1202 | 18CM-26CM1 | piece |
| Power Adapter L | XCP30-009B | Input: 100 – 240V AC 0.8A Output: 9V DC, 3A | 1 piece |
| User Manual | | | 1 piece |

Weight:

Equipment Only: 3.31 lb. (1500g)

Equipment With Complete Package: 6.17 lb. (2800g)

7 Connecting Your Monitor To The Thermometer

Step 1:

- A. First, turn on your monitor.
- B. Once powered on, press the "Menu" button.
- C. Manuever the knob to select "Wireless Setting" and press to confirm.

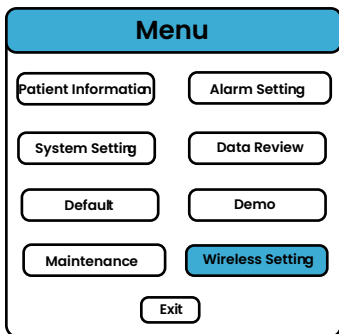
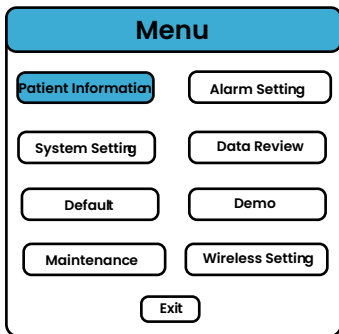

7 Connecting Your Monitor To The Thermometer (Continued)

Step 2:

- A. In the “Wireless Setting”, select the Bluetooth device as *VivaComfort Temp* under “BLE DEVICE”.

Wireless Setting

SSID:

PASSWORD:

SERVER IP:

PORT:

Bed NO:

No need to input “:” for MAC ID

BLE DEVICE:

BLE EDIT:

BLE MAC: ▼

7 Connecting Your Monitor To The Thermometer (Continued)

Step 3:

- Input the location via Bluetooth under "BLE EDIT"; enter the MAC address, found on the back of the thermometer.
- Once entered, save the settings.
- Manuever the knob to select "Wireless Setting" and press to confirm.

Wireless Setting

SSID:

PASSWORD:

SERVER IP:

PORT:

Bed NO:

No need to input ":" for MAC ID

BLE DEVICE:

BLE EDIT:

BLE MAC:

| | | | | |
|----|---|----|---|-------|
| 12 | | 34 | | 5 |
| 6 | 7 | 89 | | A |
| B | C | D | E | F |
| 0 | | | | Enter |

Wireless Setting

SSID:

PASSWORD:

SERVER IP:

PORT:

Bed NO:

No need to input ":" for MAC ID

BLE DEVICE:

BLE EDIT:

BLE MAC:

7 Connecting Your Monitor To The Thermometer (Continued)

Step 4:

A. In the Bluetooth selection, under “BLE MAC”, choose the saved MAC address.

a. The device will be automatically connected once you save and exit “Wireless Settings”.

Wireless Setting

SSID:

PASSWORD:

SERVER IP:

PORT:

Bed NO:

No need to input “:” for MAC ID

BLE DEVICE:

BLE EDIT:

BLE MAC: ▼

Appendix A FCC Declaration

This device complies with Part 15 of the FCC Rules. Operation is subject to the following two conditions:

1. This device may not cause harmful interference, and
2. This device must accept any interference received, including interference that may cause undesired operation.

Attention is drawn to changes or modifications not expressly approved by the party responsible for compliance, which could void the user's authority to operate the equipment.

NOTE: This product has been tested and found to comply with the limits for a Class B digital device, pursuant to Part 15 of the FCC Rules. These limits are designed to provide reasonable protection against harmful interference in a residential installation. This product generates, uses, and can radiate radio frequency energy and, if not installed and used in accordance with the instructions, may cause harmful interference to radio communications. However, there is no guarantee that interference will not occur in a particular installation. If this product does cause harmful interference to radio or television reception, which can be determined by turning the equipment off and on, the user is encouraged to try to correct the interference by one or more of the following measures:

Appendix A FCC Declaration (Continued)

- Reorient or relocate the receiving antenna.
- Increase the separation between the equipment and receiver.
- Connect the equipment to an outlet on a circuit different from that to which the receiver is connected.
- Consult the dealer or an experienced radio/TV technician for help.

Appendix B Compliance Information For EMC Test

Guidance and manufacturer's declaration-electromagnetic emissions and immunity.

Table 1

| Guidance and manufacturer's declaration - electromagnetic emissions | | |
|---|----------------|---|
| The monitor is intended for use in the electromagnetic environment specified below. The customer or the user of the monitor should assure that it is used in such an environment. | | |
| Emissions test | Compliance | Electromagnetic environment - guidance |
| RF emissions CISPR 11 | Group 1 | The monitor uses RF energy only for its internal function. Therefore, its RF emissions are very low and are not likely to cause any interference in nearby electronic equipment. |
| RF emissions CISPR 11 | Class A | The monitor is suitable for use in all establishments other than domestic and those directly connected to the public low-voltage power supply network that supplies buildings used for domestic purposes. |
| Harmonic emissions IEC 61000-3-2 | Not applicable | |
| Voltage fluctuations/ flicker emissions IEC 61000-3-3 | Not applicable | |

Table 2

| Guidance and manufacturer's declaration - electromagnetic Immunity | | | |
|---|---|--|---|
| The monitor is intended for use in the electromagnetic environment specified below. The customer or the user of the monitor should assure that it is used in such an environment. | | | |
| Immunity Test | IEC 60601 Test level | Compliance level | Electromagnetic environment - guidance |
| Electrostatic discharge (ESD) IEC 61000-4-2 | ±8 kV contact ±15 kV air | ±8 kV contact ±15 kV air | Floors should be wood, concrete or ceramic tile. If floors are covered with synthetic material, the relative humidity should be at least 30%. |
| Electrical fast transient/burst IEC 61000-4-4 | ±2 kV for power supply lines ±1 kV signal input/output | ±2 kV for power supply lines Not Applicable | Mains power quality should be that of a typical commercial or hospital environment. |
| Surge IEC 61000-4-5 | ±1 kV differential mode ±2 kV common mode | ±1 kV differential mode Not Applicable | Mains power quality should be that of a typical commercial or hospital environment. |

Appendix B Compliance Information For EMC Test (Continued)

| | | | |
|--|---|---|---|
| Voltage dips, short interruptions and voltage variations on power supply input lines IEC 61000-4-11 | 0% UT; 0,5 cycle At 0°, 45°, 90°, 135°, 180°, 225°, 270° and 315°. 0% UT; 1 cycle and 70% UT; 25/30 cycles; Single phase: at 0°. 0% UT; 250/300 cycle | 0% UT; 0,5 cycle At 0°, 45°, 90°, 135°, 180°, 225°, 270° and 315°. 0% UT; 1 cycle and 70% UT; 25/30 cycles; Single phase: at 0°. 0% UT; 250/300 cycle | Mains power quality should be that of a typical commercial or hospital environment. |
| Power frequency (50/60Hz) magnetic field IEC 61000-4-8 | 30 A/m 50Hz/60Hz | 30 A/m 50Hz/60Hz | Power frequency magnetic fields should be at levels characteristic of a typical location in a typical commercial or hospital environment. |
| NOTE UT is the a.c. mains voltage prior to application of the test level. | | | |

Table 3

| Guidance and manufacturer's declaration - electromagnetic Immunity | | | |
|---|--|--|--|
| The monitor is intended for use in the electromagnetic environment specified below. The customer or the user of the monitor should assure that it is used in such an environment. | | | |
| Immunity Test | IEC 60601 Test level | Compliance level | Electromagnetic environment - guidance |
| Conducted RF IEC61000-4-6 | 3 V 0,15 MHz – 80 MHz 6 V in ISM bands between 0,15 MHz and 80 MHz | 3 V 0,15 MHz – 80 MHz 6 V in ISM bands between 0,15 MHz and 80 MHz | Portable and mobile RF communications equipment should be used no closer to any part of the monitor, including cables, than the recommended separation distance calculated from the equation appropriate for the frequency of the transmitter. Recommended separation distances: $d=0.35\sqrt{P}$; $d=1.2\sqrt{P}$ |
| Radiated RF IEC61000-4-3 | 3 V/m 80 MHz – 2,7 GHz | 3 V/m 80 MHz – 2,7 GHz | 80MHz to 800MHz: $d=1.2\sqrt{P}$ 800MHz to 2.7GHz: $d=2.3\sqrt{P}$ Where, P is the maximum output power rating of the transmitter in watts (W) according to the transmitter manufacturer, d is the recommended separation distance in meters (m) Field strengths from fixed RF transmitters, as determined by an electromagnetic site survey, should be less than the compliance level in each frequency range. Interference may occur in the vicinity of equipment marked with the following symbol:  |

Appendix B Compliance Information For EMC Test (Continued)

NOTE 1 At 80 MHz and 800 MHz, the higher frequency range applies.

NOTE 2 These guidelines may not apply in all situations. Electromagnetic propagation is affected by absorption and reflection from structures, objects and people.

a Field strengths from fixed transmitters, such as base stations for radio (cellular/cordless) telephones and land mobile radios, amateur radio, AM and FM radio broadcast and TV broadcast cannot be predicted theoretically with accuracy. To assess the electromagnetic environment due to fixed RF transmitters, an electromagnetic site survey should be considered. If the measured field strength in the location in which the monitor is used exceeds the applicable RF compliance level above, the monitor should be observed to verify normal operation. If abnormal performance is observed, additional measures may be necessary, such as re-orienting or relocating the monitor.

b Over the frequency range 150 kHz to 80 MHz, field strengths should be less than 3 V/m.

Table 4

| Recommended separation distances between portable and mobile RF communications equipment and the monitor | | | |
|---|--|------------------------------------|-------------------------------------|
| The monitor is intended for use in an electromagnetic environment in which radiated RF disturbances are controlled. The customer or the user of the monitor can help prevent electromagnetic interference by maintaining a minimum distance between portable and mobile RF communications equipment (transmitters) and the monitor as recommended below, according to the maximum output power of the communications equipment. | | | |
| Rated maximum output power of transmitter W | Separation distance according to frequency of transmitter m | | |
| | 150 kHz to 80 MHz $d=3.5\sqrt{P}$ | 80MHz to 800MHz $d=1.2\sqrt{P}$ | 800MHz to 2.7GHz $d=2.3\sqrt{P}$ |
| 0,01 | /0 | .12 | 0.23 |
| 0,1/ | | 0.38 | 0.73 |
| 1/ | | 1.2 | 2.3 |
| 10 | /3 | .8 | 7.3 |
| 100 | /1 | 22 | 3 |
| For transmitters rated at a maximum output power not listed above, the recommended separation distance d in metres (m) can be estimated using the equation applicable to the frequency of the transmitter, where P is the maximum output power rating of the transmitter in watts (W) according to the transmitter manufacturer. | | | |
| NOTE 1 At 80 MHz and 800 MHz, the separation distance for the higher frequency range applies. | | | |
| NOTE 2 These guidelines may not apply in all situations. Electromagnetic propagation is affected by absorption and reflection from structures, objects and people. | | | |

Appendix B Compliance Information For EMC Test (Continued)

Table 5

| Guidance and manufacturer's declaration - electromagnetic Immunity | | | | | | | |
|---|----------------------|---------------|---|------------------------------------|-------------------|--------------|---------------------------|
| The monitor is intended for use in the electromagnetic environment specified below. The customer or the user of the monitor should assure that it is used in such an environment. | | | | | | | |
| Radiated RF IEC61000-4-3 (Test specifications for ENCLOSURE PORT MMUNITY to RF wireless communications equipment) | Test Frequency (MHz) | Band a) (MHz) | Service a) | Modulation b) | Modulation b) (W) | Distance (m) | IMMUNITY TEST LEVEL (V/m) |
| | 385 | 380 – 390 | TETRA 400 | Pulse modulation b) 18 Hz | 1,80 | ,3 | 27 |
| | 450 | 380 – 390 | GMRS 460, FRS 460 | FM c) ± 5 kHz deviation 1 kHz sine | 20 | ,3 | 28 |
| | 710 | 704 – 787 | LTE Band 13, 17 | Pulse modulation b) 217 Hz | 0,20 | ,3 | 9 |
| | 745 | | | | | | |
| | 780 | | | | | | |
| | 810 | 800 – 960 | GSM 800/900, TETRA 800, iDEN 820, CDMA 850, LTE Band 5 | Pulse modulation b) 18 Hz | 20 | ,3 | 28 |
| | 870 | | | | | | |
| | 930 | | | | | | |
| | 1720 | 1700 – 1990 | GSM 1800; CDMA 1900; GSM 1900; DECT; LTE Band 1, 3, 4, 25; UMTS | Pulse modulation b) 217 Hz | 20 | ,3 | 28 |
| | 1845 | | | | | | |
| | 1970 | | | | | | |
| | 2450 | 2400 – 2570 | Bluetooth, WLAN, 802.11 b/g/n, RFID 2450, LTE Band 7 | Pulse modulation b) 217 Hz | 20 | ,3 | 28 |
| | 5240 | 5100 – 5800 | WLAN 802.11 a/n | Pulse modulation b) 217 Hz | 0,20 | ,3 | 9 |
| | 5240 | | | | | | |
| | 5785 | | | | | | |

NOTE If necessary to achieve the IMMUNITY TEST LEVEL, the distance between the transmitting antenna and the ME EQUIPMENT or ME SYSTEM may be reduced to 1 m. The 1 m test distance is permitted by IEC 61000-4-3.

a) For some services, only the uplink frequencies are included.

b) The carrier shall be modulated using a 50 % duty cycle square wave signal.

c) As an alternative to FM modulation, 50 % pulse modulation at 18 Hz may be used because while it does not represent actual modulation, it would be worst case.

Appendix B Compliance Information For EMC Test (Continued)

The MANUFACTURER should consider reducing the minimum separation distance, based on RISK MANAGEMENT, and using higher IMMUNITY TEST LEVELS that are appropriate for the reduced minimum separation distance. Minimum separation distances for higher IMMUNITY TEST LEVELS shall be calculated using the following equation:

$$E=6/d \sqrt{P}$$

Where P is the maximum power in W, d is the minimum separation distance in m, and E is the IMMUNITY TEST LEVEL in V/m.

NOTES:

Bluetooth:

RF Receivers:

- Each frequency or frequency band of reception. (2402MHZ~2480MHZ)
- The preferred frequency or frequency band. (2402MHZ~2480MHZ)
- The bandwidth of the receiving section of the MD2000C in those bands. (2MHZ)

RF Transmitters:

- Each frequency or frequency band of transmission. (2402MHZ~2480MHZ)
- The type and frequency characteristics of the modulation. (GFSK)
- The EFFECTIVE RADIATED POWER. (5dBm)

Appendix B Compliance Information For EMC Test (Continued)

Wifi:

RF Receivers:

- Each frequency or frequency band of reception. (2400MHZ~2480MHZ)
- The preferred frequency or frequency band. (2400MHZ~2480MHZ)
- The bandwidth of the receiving section of the MD2000C in those bands. (20MHZ)

RF Transmitters:

- Each frequency or frequency band of transmission. (2400MHZ~2480MHZ)
- The type and frequency characteristics of the modulation. (OFDM)
- The EFFECTIVE RADIATED POWER. (17DBM)

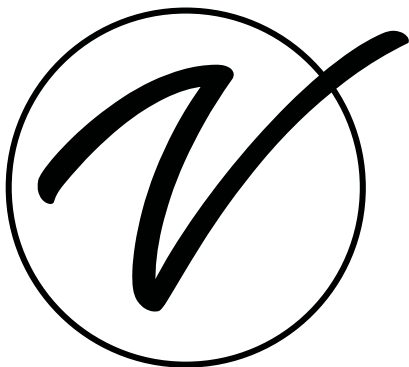

ADIME913-M

© 2025 Viva Comfort

vivacomfort.com