

.....

AXIS H-BRACE SINGLE TAPING TABLE END SHELF

.....

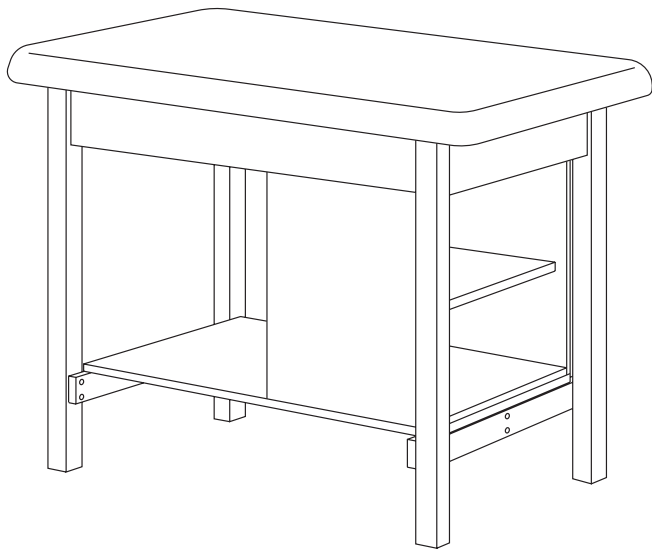

USER GUIDE

SKU: ADIME923-01-BLU-ES



Thank you for your purchase.



Viva Comfort maintains a strong practice of ongoing development of products and commercial research.



We recognize that starting and maintaining a medical practice is expensive. We'll help make the process cost-effective and elegant. Additionally, our team of specialists will ensure everything you need works as efficiently as possible, so you can effectively treat your clients.

Table of Contents

- 4 Parts List
- 4 Hardware List
- 5 Lower Shelf Installation
- 6 End Shelf Installation
- 11 Care & Maintenance Guide
- 10 Safety Warning
- 11 Warranty
- 14 Notes

Lower Shelf Installation

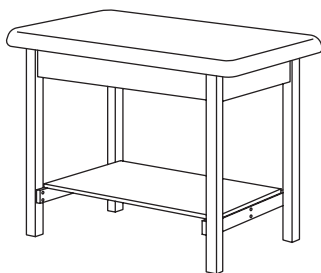

Parts List

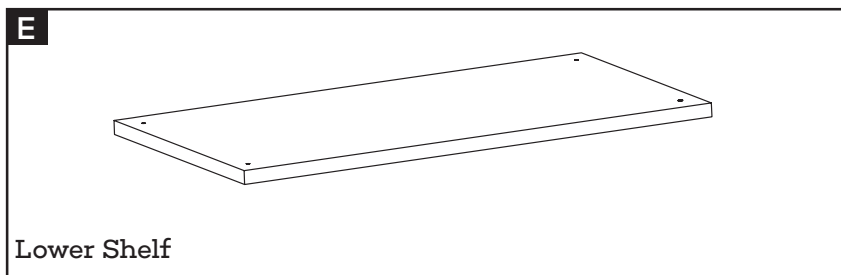

Hardware List

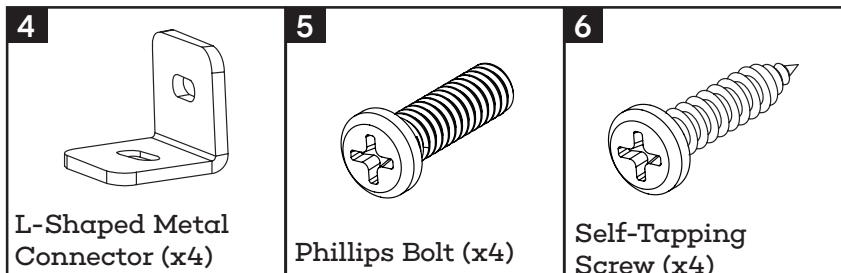

Step 1:

- A. If the product you purchased includes a Lower Shelf (E), please use Phillips Bolts (5) to secure the L-Shaped Metal Connector (4) to the built-in reserved nut of the Lower Shelf (E) as shown.

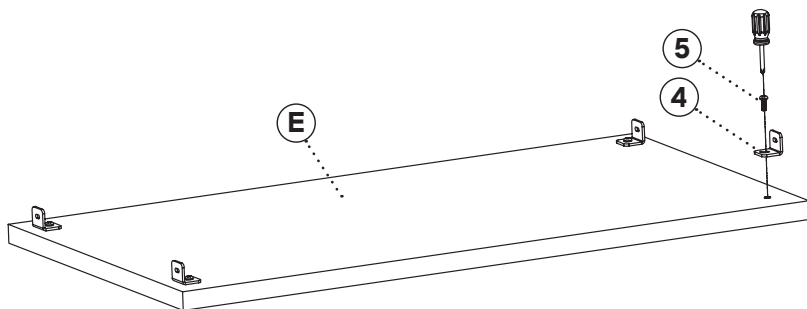

Step 2:

- A. Fix the L-Shaped Metal Connector (4) to the Short Beams' (C) reserved hole using Self-Tapping Screws (6), as shown.

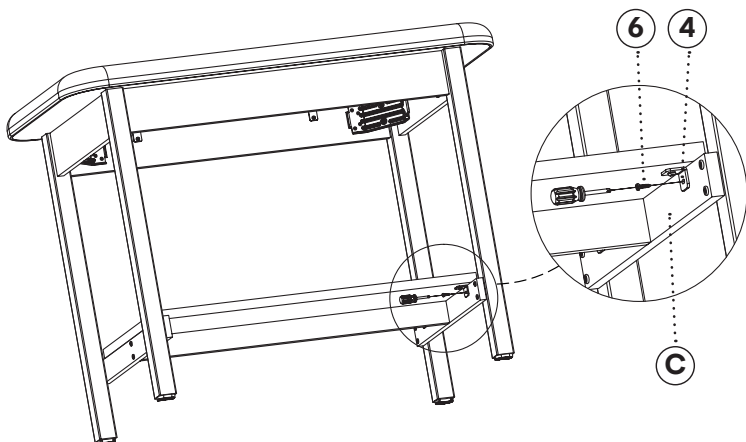

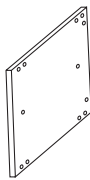
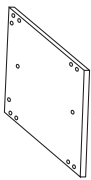
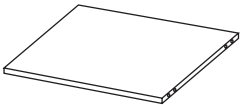
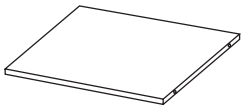
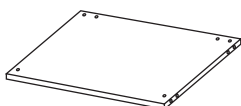
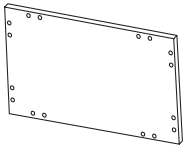

End Shelf Installation

Parts List

F  Left Panel	G  Right Panel	H  Top Panel
I  Middle Shelf	J  Bottom Panel	K  Back Panel

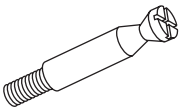
Hardware List

7  Connecting Rod Bolt (x16)	8  Wooden Pin (x8)	9  Fixing Screw (x16)
--	--	---

Step 3:

- A. Locate and insert all Wooden Pins (11) into the reserved holes on all the Panels (F), (G), (H), (I), (J), (K) to be assembled.
- B. Install all the Connecting Rod Bolts (10) on the reserved nuts on the panels to be constructed.
- C. This product is installed with a four-in-one connector. Please use a screwdriver to adjust the direction of the embedded lock cap slot so that it is parallel to the axis of the Connecting Rod Bolt (10).

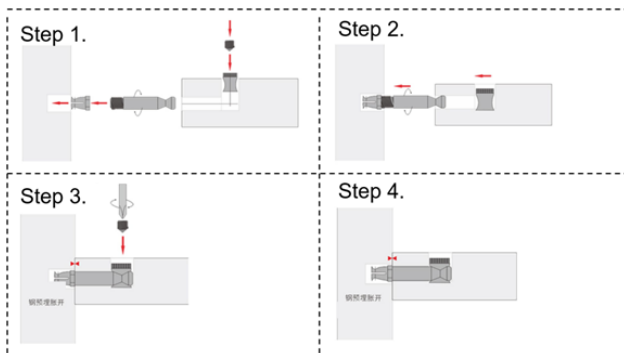
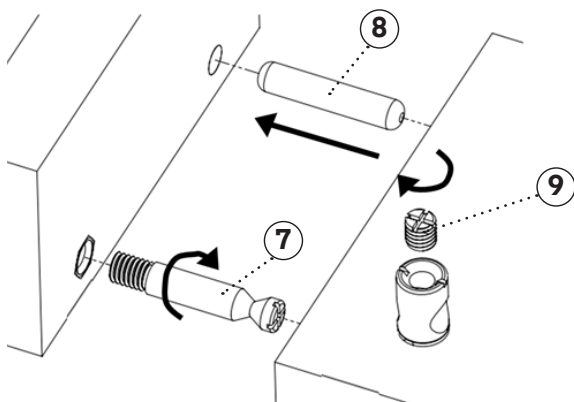

Step 4:

A. Assemble the Left Panel (H), Right Panel (G) to the Bottom Panel (J), Top Panel (I), Middle Panel (I), and BackPanel (K) as shown. Insert the Fixing Screws the holes located on the interior of the panel.

a. Tighten the Fixing Screws (9) with a Philips head Screwdriver.

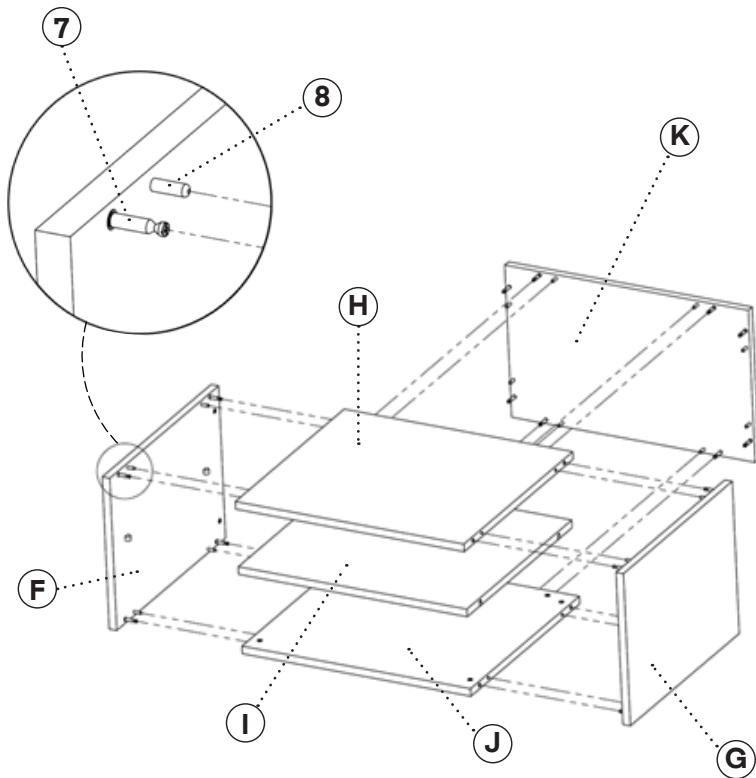

Step 5:

- A. Stick the male and female Velcro to the bottom of the cabinet and the corresponding shelf installation position, and then place the cabinet in the appropriate position on the Lower Shelf (E).

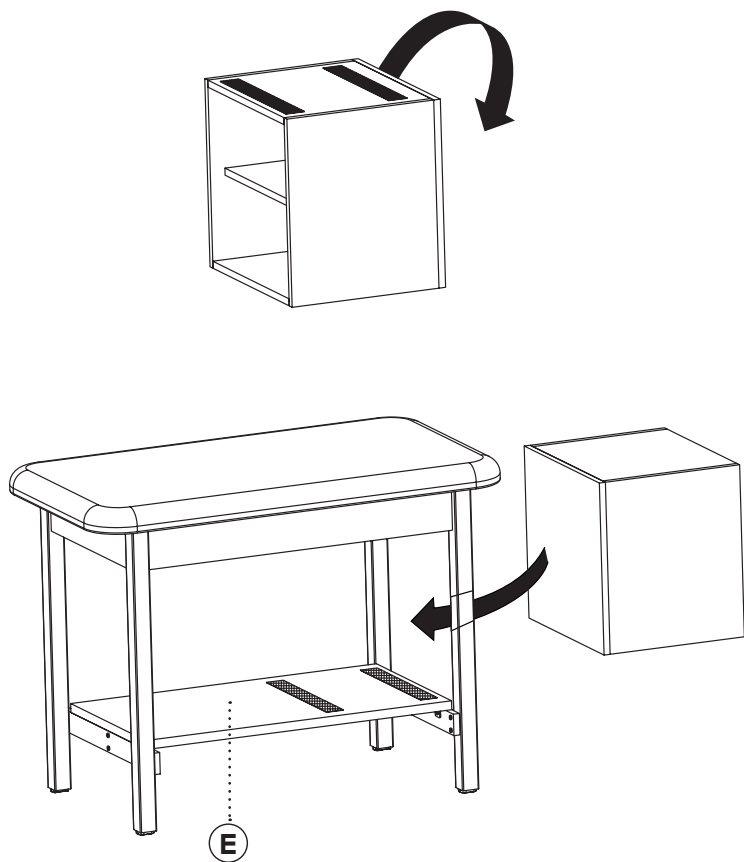

Care & Maintenance Guide

A. Leather Maintenance:

a. It is recommended to use a small amount of neutral detergent/cleaner or wipe with a dry towel when wiping the leather, then wipe it clean with a dry cloth, dry it, and place it in a ventilated place to dry.

b. If disinfection is necessary, it is acceptable to use hypochlorous acid disinfectant or alcohol below 70% concentration to wipe it. It is prohibited to use highly corrosive disinfectants for disinfection; otherwise, they may accelerate the aging of the leather, causing the leather to change color, deform, harden, become brittle, or even peel off the surface.

c. When not used for a long time, it is recommended that the table be covered with a table cover and stored in a dry environment. Avoid direct sunlight, rain, humidity, and other environments.

d. Too high or too low-temperature environments may accelerate the aging of leather.

e. Sharp objects are prohibited from touching the leather surface.

B. Wood Maintenance:

a. A dry towel is recommended to wipe the wood parts.







b. If disinfection is necessary, it is acceptable to use hypochlorous acid disinfectant with an alcohol concentration below 70% for wiping. It is prohibited to use highly corrosive disinfectants for disinfection; otherwise, the paint or wood veneer may be damaged.

C. Regular Maintenance:

a. Inspect the table surface every 3 months to check the stability of the table frame when it is pushed horizontally, vertically, or laterally. If there is any shaking, tighten the connecting bolts.

Safety Warning

A. The user is ultimately responsible for preventing product damage or injury to the patient and/or surgical staff.

	WARNING: Indicates potential personal injury.
	Consult instructions for use.
	WARNING: Tip-over hazard; do not step on the table shelf.
	Warning: Be careful of pinching fingers.
	Reminder: Keep away from moisture. This device needs to be moisture and water-proof.
	Reminder: Always place the packaging box in the correct direction during transportation, storage, and handling to avoid damage and safety problems caused by incorrect placement.
	Reminder: This product is fragile and needs to be handled with care.

B. Collapse risk:

 If the patient's weight exceeds the working load or the patient's weight is not evenly distributed on the table surface, the athletic taping table may collapse.

 If the weight of the stored items exceeds the working load of the lower shelf, or the lower shelf may deform or break.

C. Infection risk:

When cleaning, please wear gloves, masks, and eye protection to prevent the cleaning spray from rebounding from the contaminated surface.

E. Table surface damage risk:

a. The ambient temperature requirement for using and storing the equipment is 0-40°C. If the equipment is exposed to an environment exceeding the specified temperature for a long time, the leather surface may crack or peel.

b. The humidity requirement for the equipment's transportation, use, and storage is 20%~80%. The leather surface may crack or peel if the equipment is exposed to an overly dry or humid environment for a long time.

c. The leather of the equipment table is strictly prohibited from contacting acidic and alkaline substances. Scrubbing the table with a non-neutral detergent may cause the leather to crack and peel prematurely, reducing its service life.

d. The leather of the table is strictly prohibited from contacting liquid water. Liquid water may penetrate the leather, causing the sponge inside the leather to degenerate, affect use, or crack and peel.

F. Hardware accessories rusting risk

a. The humidity requirement for equipment transportation, use, and storage environment is 20%~80%. If the equipment is exposed to an overly humid environment for a long time, the hardware accessories may rust.

b. The metal parts of the equipment are prohibited from contacting acidic substances; otherwise, they may cause damage to the paint surface and then rust.

c. The metal parts of the equipment are prohibited from contacting liquid water, which may cause metal materials to rust.

7. Other precautions:

a. It is strictly prohibited to approach fire sources.

b. Do not place it in direct sunlight.

c. Do not place it in high-temperature places such as heaters.

Warranty

1. Viva Comfort (the "Company" or "Tiger Companies") warrants to the purchaser that the product will be free from defects in workmanship and materials for a period of 1 year from the date of purchase. The warranty period is not extended if we repair, replace, exchange, or provide a refund for the product (as determined in our sole discretion). We may change the availability of this limited warranty at our discretion, but any changes will not be retroactive.
2. These warranties are not assignable or transferable to any other person, including, without limitation, any subsequent owner or other transferee of the product.
3. This Warranty does not apply to: (a) damage caused by misuse, tampering, abuse, neglect, or accident; (b) damage caused by improper installation, modification, or service; (c) alteration of the serial number; or (d) use that violates the instructions furnished by the Company will void this warranty.
4. The sole responsibility of the Company shall be limited to (a) the repair or replacement (in its sole discretion) of any component of the product which fails to conform to this; (b) a refund the purchase price of such product (in its sole discretion), at no cost to the purchaser for the period of the warranty, or (c) an exchange for a similar product, comparable in function and price.
5. Contact the Company directly at 1-(800)-805-1790 to obtain service under this warranty. If it becomes applicable to send a defective product to the Company, a Return Authorization Number must first be obtained from the Company. In order to obtain service under this warranty, purchaser may be required to provide the Company with the following items (a) proof of purchase, (b) photographs and or videos (of the damage, and (c) a written testimonial describing the defect.
6. Products shipped without prior Return Authorization and Return Authorization Number may not be accepted, and the Company will not be responsible for their disposition and/or cost of return to the owner.
7. The Company will not assume any responsibility for any loss or damage incurred in shipping and or delivery.
8. The product(s) must be returned within 14 calendar days of receiving the return authorization from the Company and must include the original proof of purchase for the warranty to be honored.
9. Any implied warranties that the purchaser may have are limited to the duration of the warranties described above. There are no further warranties that extend or apply beyond the face hereof, and the Company expressly disclaims and excludes any and all warranties of merchantability or fitness for a particular purpose. Some states do not allow limitations on how long an implied warranty lasts, so the above limitation may not apply to you.
10. THE REMEDIES DESCRIBED ABOVE ARE YOUR SOLE AND EXCLUSIVE REMEDIES AND THE COMPANY'S ENTIRE LIABILITY FOR ANY BREACH OF THIS LIMITED WARRANTY. OUR LIABILITY SHALL UNDER NO CIRCUMSTANCES EXCEED THE ACTUAL AMOUNT PAID BY YOU FOR THE DEFECTIVE PRODUCT, NOR SHALL WE UNDER ANY CIRCUMSTANCES BE LIABLE FOR ANY CONSEQUENTIAL, INCIDENTAL, SPECIAL OR PUNITIVE DAMAGES OR LOSSES, WHETHER DIRECT OR INDIRECT. SOME STATES DO NOT ALLOW THE EXCLUSION OR LIMITATIONS OF INCIDENTAL OR CONSEQUENTIAL DAMAGES, SO THE LIMITATION MAY NOT APPLY TO YOU.
11. This warranty gives you specific legal rights, and you may also have additional rights which vary from state to state.

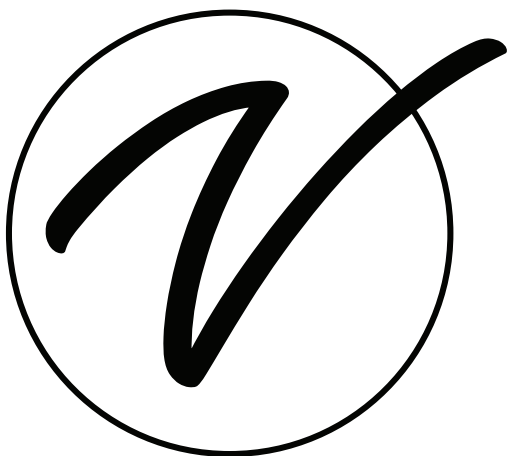

ADIME923-01-BLU-ES

© 2025 Viva Comfort

vivacomfort.com