

.....

HI-LO CHANGING TABLE WITH SIDE RAILS

.....

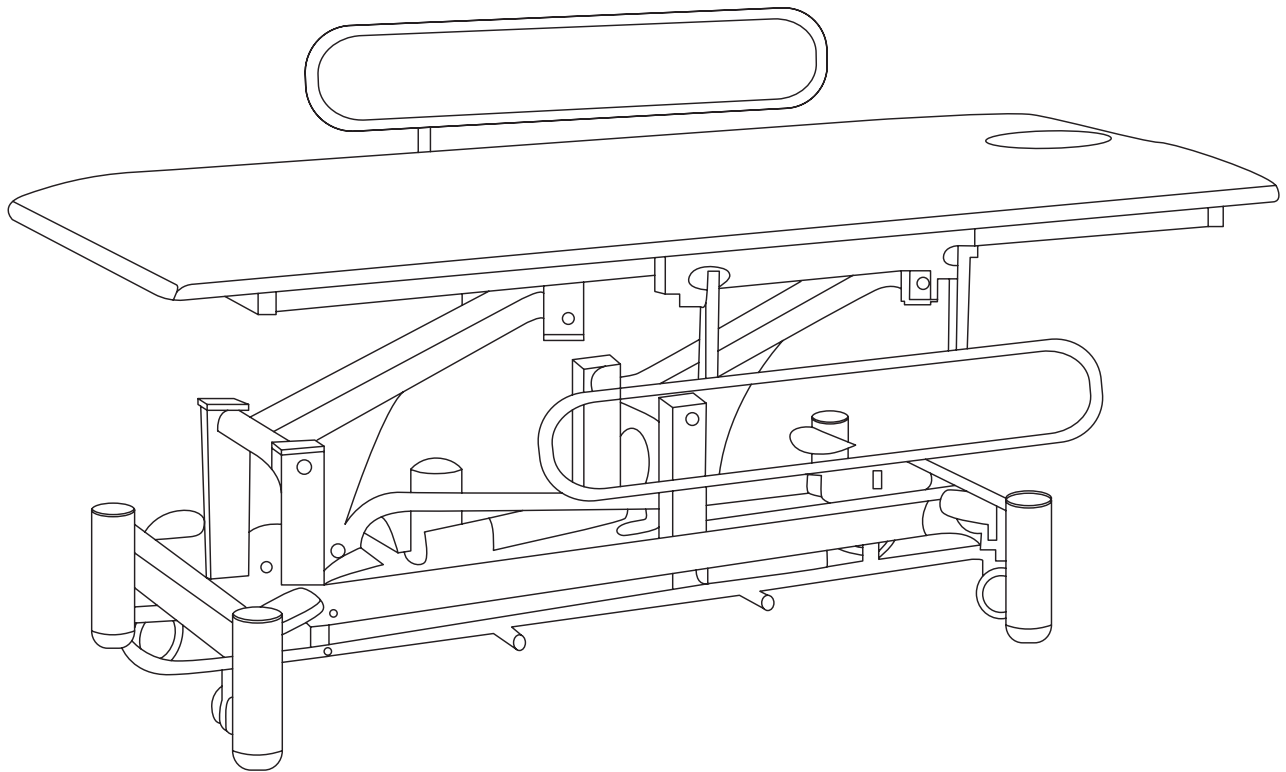

USER GUIDE

ADI903-03



Thank you for your purchase.

Viva Comfort maintains a strong practice of ongoing development of products and commercial research.

We recognize that starting and maintaining a medical practice is expensive. We'll help make the process cost-effective and elegant. Additionally, our team of specialists will ensure everything you need works as efficiently as possible, so you can effectively treat your clients.

Table of Contents

- 2 Important Safety Information
- 4 Instructions For Use
- 7 Maintenance and Care
- 8 Warranty
- 9 Notes

Important Safety Information

WARNING

- Improper setup, operation, or poorly maintained equipment may cause personal injury.
- To avoid this hazard, read and follow the instructions in this manual carefully.
- Check the padding and upholstery when unpacking the table. Do not use it if there are signs of damage. (Our warranty excludes damage caused to the table by improper setup, accident, abuse, or use other than the table's intended purpose.)

SAFETY INSTRUCTIONS

READ THE FOLLOWING CAREFULLY AND ENSURE THAT ALL STAFF MEMBERS WHO OPERATE THE TABLE ARE FULLY BRIEFED ON SAFETY COMPLIANCE.

- Do not place your hands or feet near the table's moving parts while adjusting the table sections.
- Use both hands to adjust the angle or the height of any section of the table.
- Do not adjust the section angle when a client is on the table.
- Do not crawl under the table under any circumstances to avoid injury from a potential table collapse.
- Be certain that the table is properly placed on a flat surface before allowing a client to lie on it; otherwise, the patient may lose balance and fall.
- Do not put excessive weight or pressure on the headrest or table extender.
- Keep children and pets away from the table.

WARNING: This product can expose you to chemicals including Lead and Di(2-ethylhexyl) phthalate (DEHP) which are known to the State of California to cause cancer and birth defects or other reproductive harm. For more information please go to **WWW.P65WARNINGS.CA.GOV**

Important Safety Information

ELECTRIC SHOCK DANGER

- The power supply/control box is located below the table. For safety purposes, DO NOT touch the power supply and control box when the table is in operation.
- Set up the table and complete all the preparatory work before connecting the power.
- Check the voltage rating on the serial plate of the motor. The motor's plug should only be inserted into a **110 VAC or 220 VAC** power outlet as indicated on the serial plate.
- Do not expose the table to extreme moisture or temperature to avoid shorting the power/control box.

WEIGHT LIMIT:

Lifting Capacity: **550 Lbs/250kgs** (including client and accessories)

Instructions For Use

ADJUSTING THE HEIGHT OF THE TABLE:

- Height adjustment is achieved with the foot bar switch.
- The Hi-Lo function could be adjusted from four sides.

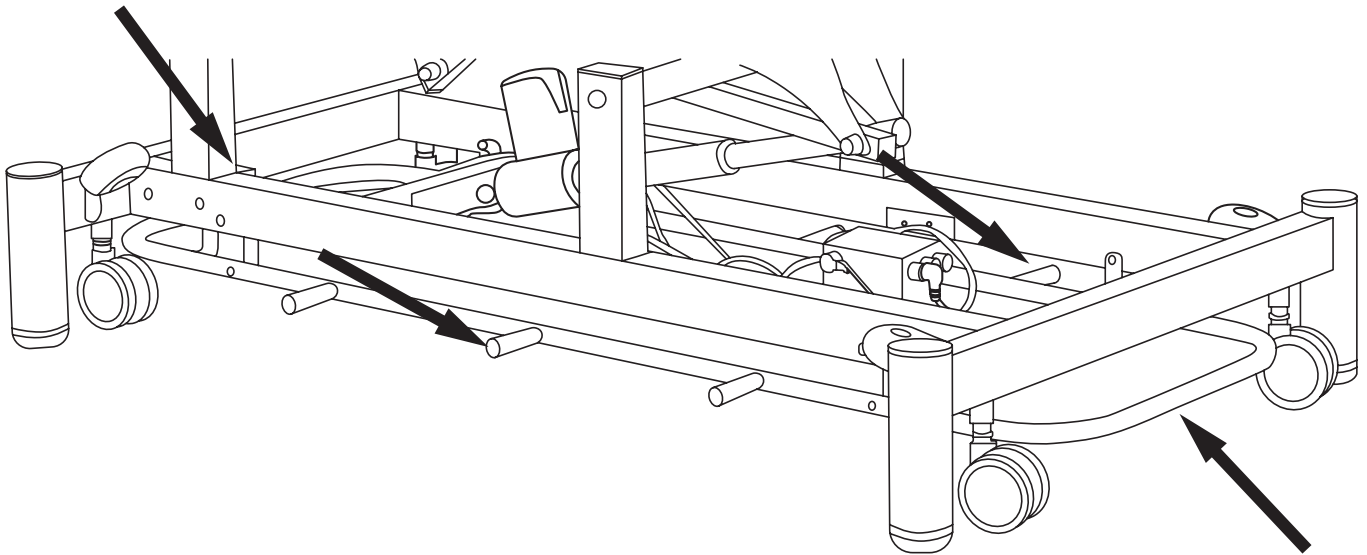

- **TO RAISE THE TABLE:** Push the foot bar control to left.
- **TO LOWER THE TABLE:** Push the foot bar control to the right.

Instructions For Use

FOLD-DOWN SIDE SUPPORT (PAIR)

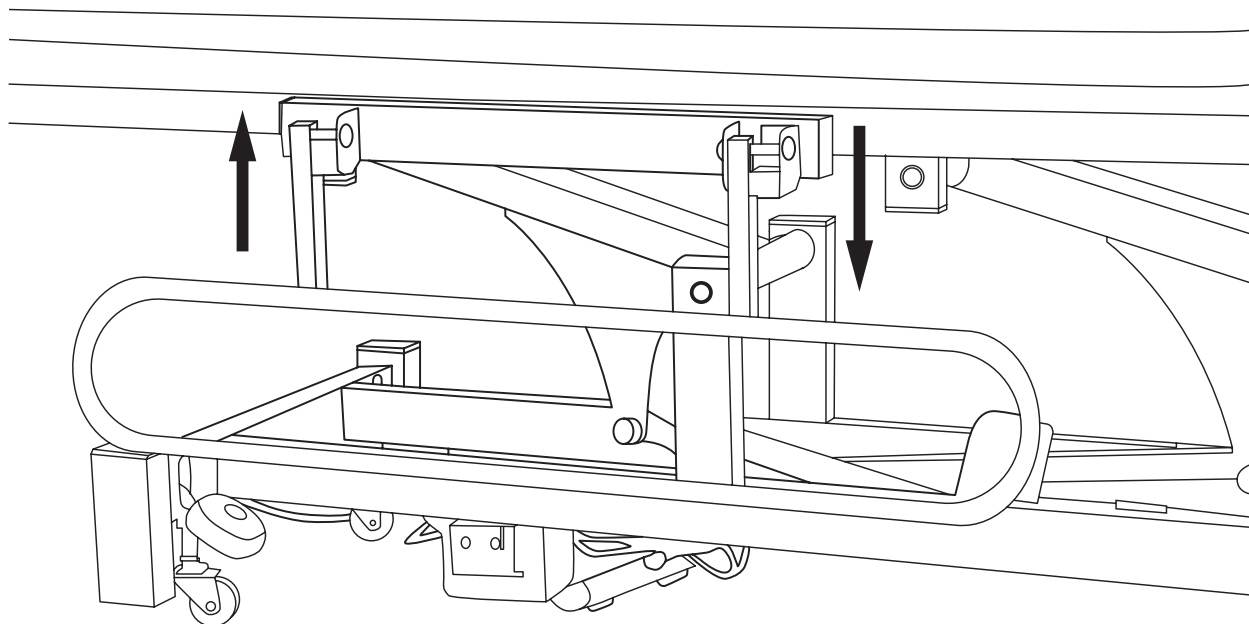

APPLYING THE FOOT RELEASE CASTER SYSTEM

- **TO MAKE MOBILE:** Place your foot on the positioning lever and push downward.
- **TO MAKE STATIONARY:** Lift the positioning lever up with your foot.

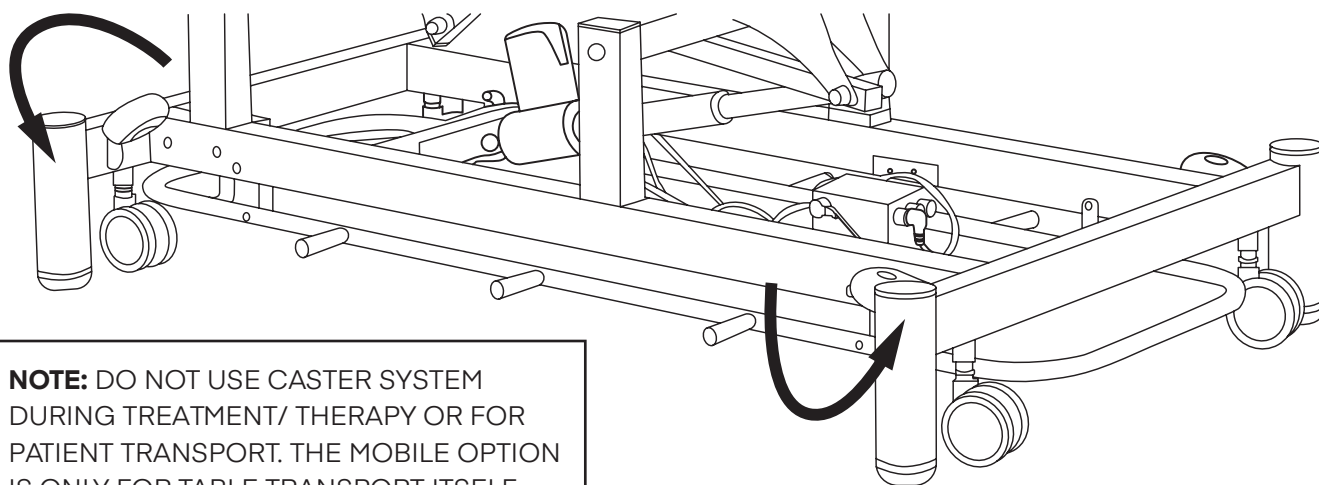

NOTE: DO NOT USE CASTER SYSTEM DURING TREATMENT/ THERAPY OR FOR PATIENT TRANSPORT. THE MOBILE OPTION IS ONLY FOR TABLE TRANSPORT ITSELF.

Instructions For Use

USING THE ADJUSTABLE FOOT:

Each table comes with four adjustable feet. It can adjust up or down to stabilize the table if it is on an uneven surface.

CAUTION: DO NOT USE THE FOOT LEVER SYSTEM DURING TREATMENT/THERAPY OR FOR PATIENT TRANSPORT. THE MOBILE OPTION IS ONLY FOR TABLE TRANSPORT ITSELF.

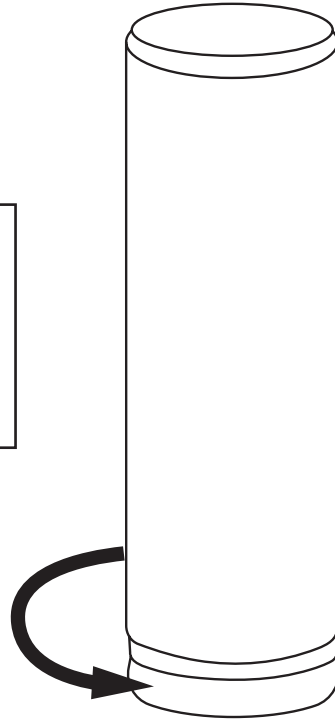

Maintenance and Care

Please make sure your table is serviced yearly to ensure your table functions to its maximum capability. Lubrication of pivot points and moving points on the table frame must be done regularly.

Electrically powered tables are equipped with a long-running, maintenance-free electric motor. Should any problems occur with this unit, please contact us.

HOW TO CARE FOR YOUR UPHOLSTERY FABRIC

Here are some steps to protect the table's upholstery and ensure the longevity of the product.

- Avoid storing the table in frigid temperatures since the excessive cold will cause the upholstery to crack. Keeping the table in an unheated area during the winter is not recommended.
- Avoid storing the table in hot temperatures since the excessive heat will cause the upholstery to stretch and pucker. Keep the table away from heaters, electrical appliances, direct sunlight, and the inside of your car during hot weather.
- Clean the table's upholstery after each day of use. We recommend cleaning the upholstery with a mild detergent to protect it against oil stains and set-in dirt. A common practice is to use a spray bottle filled with a mixture of anti-bacterial dish soap and water on the upholstery, followed by a wipe down with a clean towel.
- Protect the table from general abrasions, cuts, and punctures.

CAUTION

- RUBBING ALCOHOL WILL DRY OUT THE UPHOLSTERY AND CAUSE IT TO CRACK.
- MOISTURE MAY CAUSE THE ELECTRIC ACTUATOR TO SHORT. KEEP THE TABLE AWAY FROM WATER.

Warranty

1. Viva Comfort (the "Company" or "Tiger Companies") warrants to the purchaser that the product will be free from defects in workmanship and materials for a period of three (3) years from the date of purchase. The warranty period is not extended if we repair, replace, exchange, or provide a refund for the product (as determined in our sole discretion). We may change the availability of this limited warranty at our discretion, but any changes will not be retroactive.
2. These warranties are not assignable or transferable to any other person, including, without limitation, any subsequent owner or other transferee of the product.
3. This Warranty does not apply to: (a) damage caused by misuse, tampering, abuse, neglect, or accident; (b) damage caused by improper installation, modification, or service; (c) alteration of the serial number; or (d) use that violates the instructions furnished by the Company will void this warranty.
4. The sole responsibility of the Company shall be limited to (a) the repair or replacement (in its sole discretion) of any component of the product which fails to conform to this; (b) a refund the purchase price of such product (in its sole discretion), at no cost to the purchaser for the period of the warranty, or (c) an exchange for a similar product, comparable in function and price.
5. Contact the Company directly at 1-(800)-805-1790 to obtain service under this warranty. If it becomes applicable to send a defective product to the Company, a Return Authorization Number must first be obtained from the Company. In order to obtain service under this warranty, purchaser may be required to provide the Company with the following items (a) proof of purchase, (b) photographs and or videos (of the damage, and (c) a written testimonial describing the defect.
6. Products shipped without prior Return Authorization and Return Authorization Number may not be accepted, and the Company will not be responsible for their disposition and/or cost of return to the owner.
7. The Company will not assume any responsibility for any loss or damage incurred in shipping and or delivery.
8. The product(s) must be returned within 14 calendar days of receiving the return authorization from the Company and must include the original proof of purchase for the warranty to be honored.
9. Any implied warranties that the purchaser may have are limited to the duration of the warranties described above. There are no further warranties that extend or apply beyond the face hereof, and the Company expressly disclaims and excludes any and all warranties of merchantability or fitness for a particular purpose. Some states do not allow limitations on how long an implied warranty lasts, so the above limitation may not apply to you.
10. THE REMEDIES DESCRIBED ABOVE ARE YOUR SOLE AND EXCLUSIVE REMEDIES AND THE COMPANY'S ENTIRE LIABILITY FOR ANY BREACH OF THIS LIMITED WARRANTY. OUR LIABILITY SHALL UNDER NO CIRCUMSTANCES EXCEED THE ACTUAL AMOUNT PAID BY YOU FOR THE DEFECTIVE PRODUCT, NOR SHALL WE UNDER ANY CIRCUMSTANCES BE LIABLE FOR ANY CONSEQUENTIAL, INCIDENTAL, SPECIAL OR PUNITIVE DAMAGES OR LOSSES, WHETHER DIRECT OR INDIRECT. SOME STATES DO NOT ALLOW THE EXCLUSION OR LIMITATIONS OF INCIDENTAL OR CONSEQUENTIAL DAMAGES, SO THE LIMITATION MAY NOT APPLY TO YOU.
11. This warranty gives you specific legal rights, and you may also have additional rights which vary from state to state.



ADI903-03

© 2023 Viva Comfort

vivacomfort.com