

.....

MULTI-USE IMAGING POWER
EXAM TABLE WITH 3-SECTION
TOP AND DROP WINDOW

.....

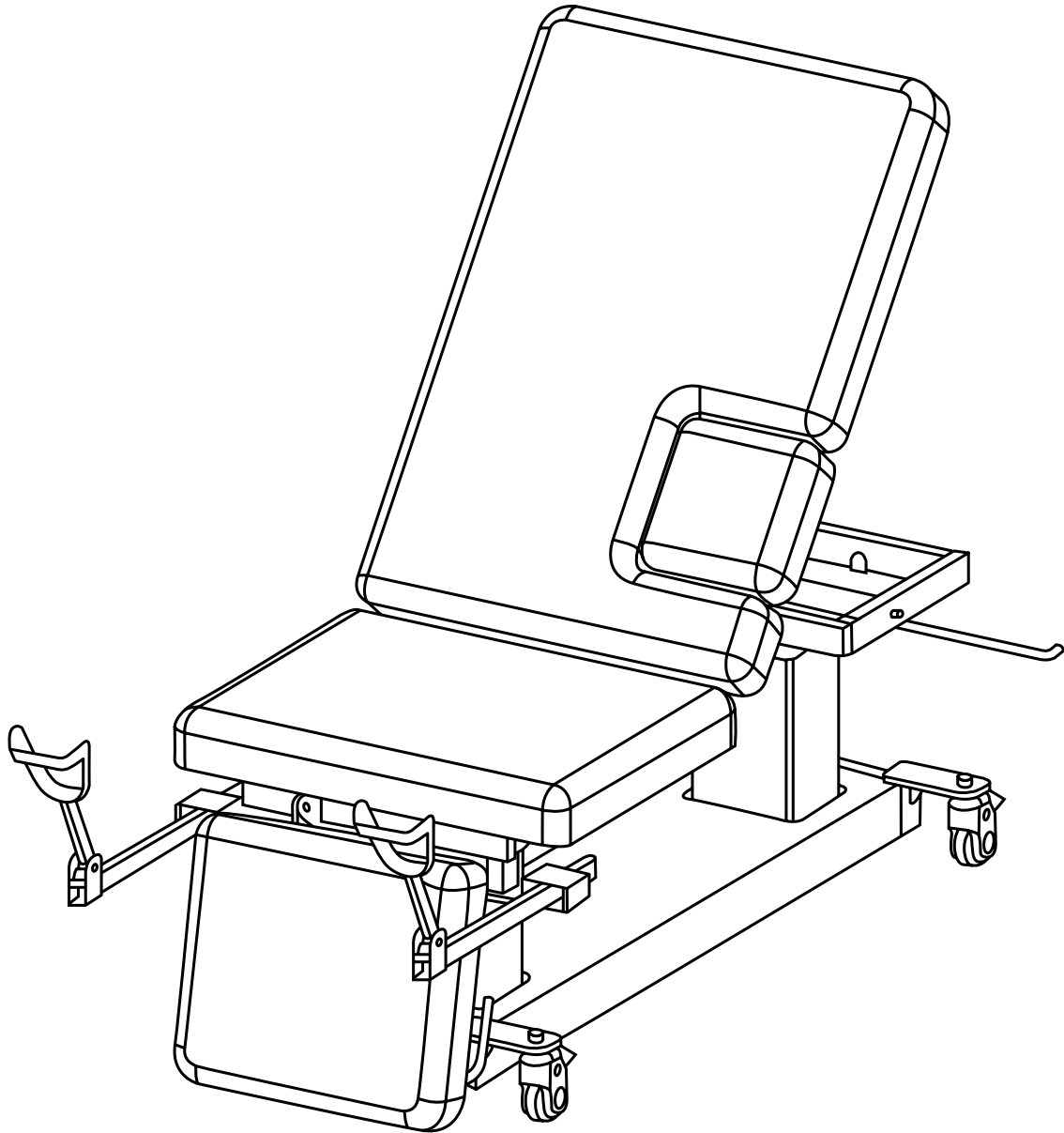

USER GUIDE

SKU: ADI903-04



Thank you for your purchase.

Viva Comfort maintains a strong practice of ongoing development of products and commercial research.

We recognize that starting and maintaining a medical practice is expensive. We'll help make the process cost-effective and elegant. Additionally, our team of specialists will ensure everything you need works as efficiently as possible, so you can effectively treat your clients.

Table of Contents

2	Safety Precautions
2	Normal Operating Conditions
5	Precautions and Safety Indications
6	Operations
9	Installation of Stirrups
10	Installation of Side Rails
11	Installation of Paper Roll Dispenser
12	Troubleshooting and Maintenance
12	Recycling
13	Cleaning and Disinfecting
13	Transportation and Storage Conditions
13	Shutdown Procedure
14	Warranty
15	Notes

Safety Precautions

1. During the adjustment of the table, do not put any part of the body into the gap of any moving parts.
2. Please operate with both hands when adjusting the leaning angle of the back, foot, or head sections.
3. When the patient is on the table, it is not recommended to adjust the angle of the tabletop.
4. Before using the product, ensure the four feet of the table frame touch the ground at the same time and check the stability of the table frame.
5. Before connecting to the power supply, please check whether the incoming line to the controller is intact.
6. A regular inspection (at least once a year) is needed for the treatment table.
7. Do not exceed the table weight capacity of 551.1 lb. (250 kg.). The safe working load of the arm rest is 15 kg.
8. Always clean the table after each use with a soft cloth dampened with water and a mild antibacterial detergent. Do not use abrasive cleaners.
9. Disconnect the table from the power source before attempting any maintenance, installation, removal or replacement procedures to prevent electrical shock and possible damage to the table.
10. Please **DO NOT** make any changes to the table. Replacement parts or labor furnished can be provided by CoinfyCare, the selling dealer or a service technician certified by the manufacturer.

Normal Operating Conditions

Temperature: 41°C- 104 °C

Relative humidity: 30% - 75%

Air pressure range: 860-1060hpa

Power supply: AC 220V \pm 10%, 50Hz

Precautions and Safety Indications

Viva Comfort is not liable for any material or personal damage due to misuse or incorrect use of this table or for any purpose other than described in this user guide.

Inspect the condition of the table before using it for the first time and on a recurring basis as indicated in the "MAINTENANCE" section.

This table generates, uses, and can radiate radio frequency energy and, if not installed and used in accordance with the instructions, may cause harmful interference to other devices in the vicinity. However, there is no guarantee that interference will not occur in a particular installation. Harmful interference to other devices can be determined by turning this table on and off. Try to correct the interference using one or more of the following:

1. Reorient or relocate the receiving device.
2. Increase the separation between the equipment.
3. Connect the table to an outlet on a different circuit from that which the other device(s) are connected.
4. Consult Viva Comfort for help.

Please carefully review the following precautions and warning prior to use:

- Keep the table out of high moisture environments.
- Do not transport the table over rough or outdoor surfaces. The retractable caster system could become damaged and inoperable.
- This table should be operated, transported, and stored in temperatures between 41° F to + 113° F, with max humidity of 75%.
- DO NOT operate this table in an environment where other devices are being used that intentionally radiate electromagnetic energy in an unshielded manner.
 - o Portable and mobile communications equipment can affect Medical Electrical Equipment.
- Before cleaning or conducting any form of maintenance, unplug the table from its power supply.
- The table should be kept out of the reach of children when there is no adult supervision.
- The table is designed for discontinuous interval operation, so the continuous running time of the motor should never exceed 2 minutes.
 - o Should this happen, damage may occur due to overheating of the electronics.
- Always use original accessories and spare parts provided by your local dealer.
- Always cover the table with a towel, disposable paper, or a cover and change it for each user, thus ensuring correct hygiene and extending the useful life of the upholstery.
- Only connect the table to a properly installed and grounded outlet.
 - o The local mains voltage must correspond to the technical data of the device.
 - o The power outlet should be accessible in case the table needs to be quickly unplugged at any given time.
 - Always pull the plug and not the mains cable.
 - o If the electrical supply cable is defective, disconnect the table immediately and inform your dealer or a specialized technician.
- Position the power cord properly so that it cannot be tripped over.
- Unplug the power cord from the mains if the table is not going to be used for a long period of time.
- If you detect any abnormality in the operation of the table, consult your dealer or a specialized technician.

Precautions and Safety Indications

- Never manipulate any electrical part or open or repair any part of the table.
 - Only your dealer or a specialized technician should repair the table.
- Never touch the table or the power cord with wet hands.
- Never place your hands or any other part of your body in any hole or void on the table while it is in operation.
- Make sure there are no objects in the space under the table that could cause collisions or entrapment during operation.
- Make sure that your feet are not resting on the peripheral foot bar or foot control during treatment and, especially when sitting near the table.
 - This could create a dangerous situation where your leg is caught between the section and the peripheral foot bar or floor surface.
- Take into account the weight distribution on the table when working.
 - The weight must be distributed along the table without concentrating on its ends to maintain the correct stability.
 - You should not sit on the head and foot sections.

Operations

Power Your Table

A. Connect the bed to an electrical outlet using the power cord to start utilizing your table.

Moving Your Table

A. The bed bottom frame is equipped with four control casters, controlled by a brake switch on both ends of the table.

B. Push the brake switch (long handle) of the casters up; the casters will be unlocked.

- a. The table is now in a moving status, so you can maneuver it where needed.

C. Push the brake switch (long handle) of the casters down; the casters will be locked.

- a. The table is now in a fixed status and cannot be moved.

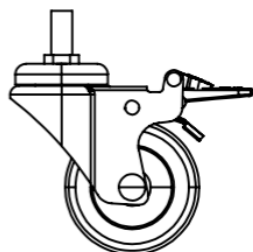

Unlock

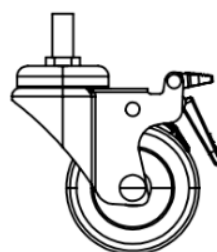

Lock

Hand Control Connection

A. When the indicator light is on, the hand control is powered on and can be controlled.

B. Press it again; the power is turned off, and the hand control cannot work.

Hand Control Function

A. The hand control is for adjusting the tilt, height & backrest angle.

B. Before adjusting, make sure there are no objects in the space below the table that could cause collisions or entrapment.

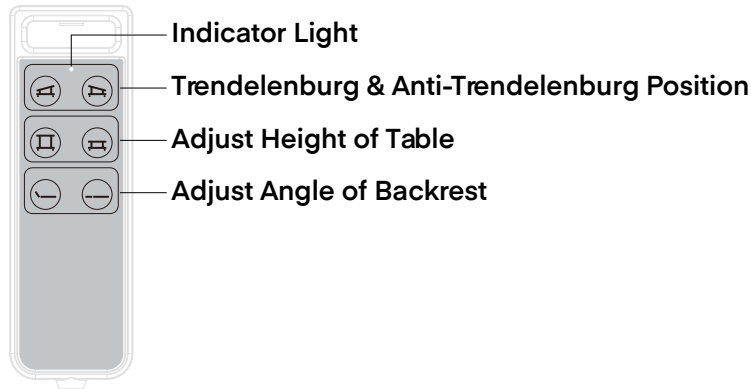

C. To adjust the Trendelenburg and anti-Trendelenburg positions by 20 degrees, press the line 1 button on the controller panel.

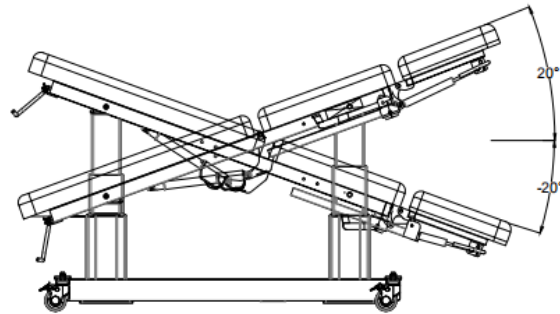

D. To adjust the height of the table, press the line 2 button on the controller panel.

a. Before operation, please confirm that there are no objects in the space under the bed.

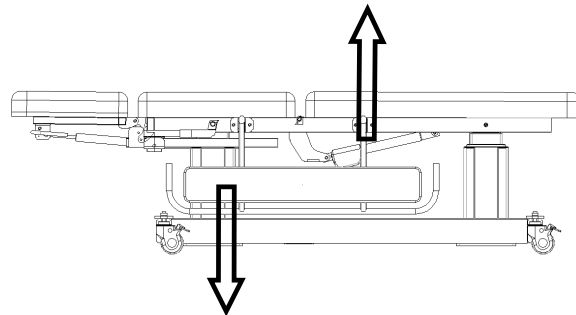
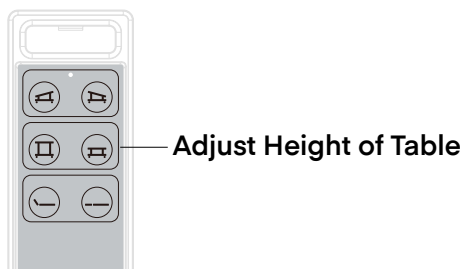

E. To adjust the angle of the backrest by 80 degrees, press the line 3 button on the controller panel

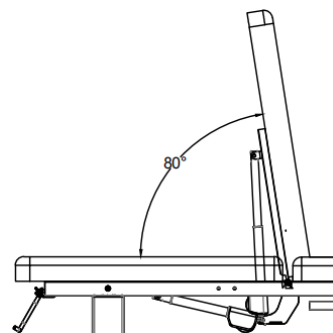
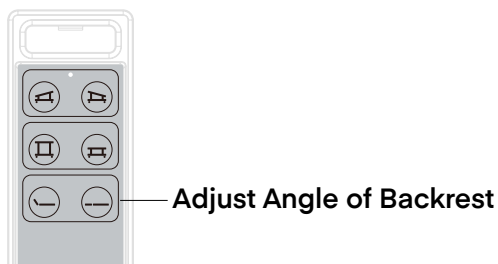

Operations

Adjusting Leg Plate Angle

A. Pull the control lever (in the direction shown by the arrow) to adjust vertically down the leg plate angle by 80 degrees.

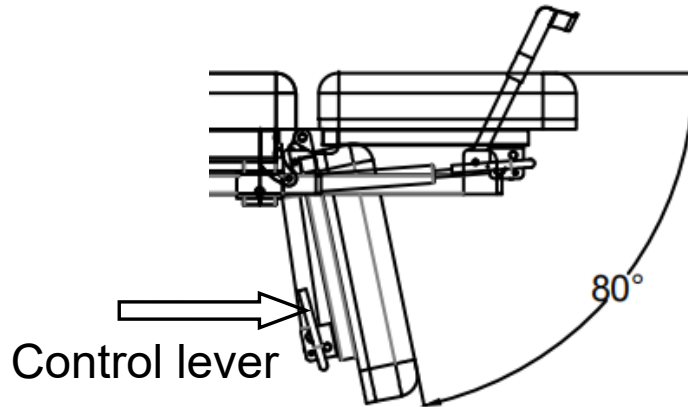

Adjusting Drop Window (Fold Down)

- A. The drop window can be folded down by adjusting the buckle and hook under the drop window plate.
- B. Pull the control lever (in the direction shown by the arrow) to fold down the drop window.
- C. Pull the drop window up, and the hook will be closed automatically.

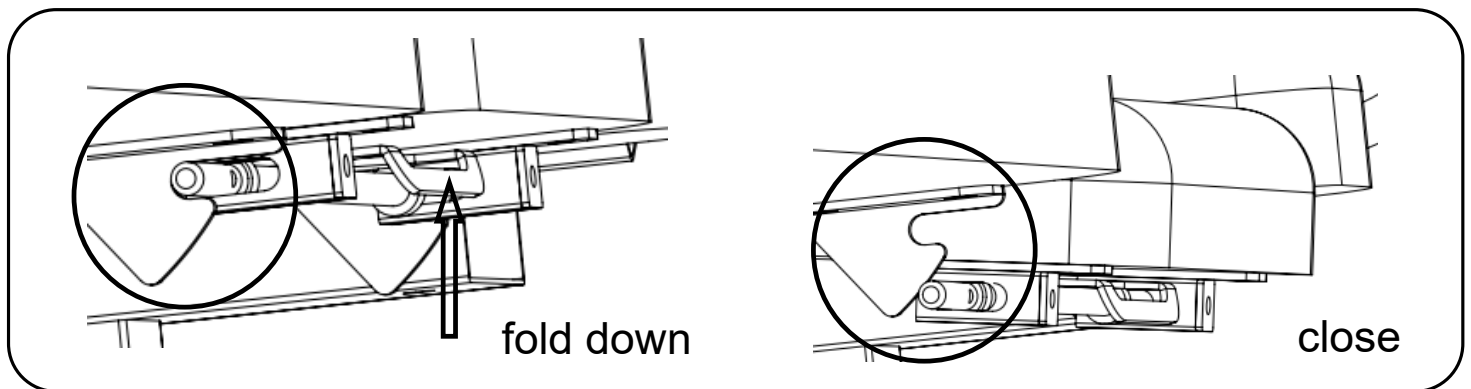

Installation of Stirrups

A. The stirrups are folded and installed on both sides of the frame.

B. Insert the stirrup into the tube on exam table frame.

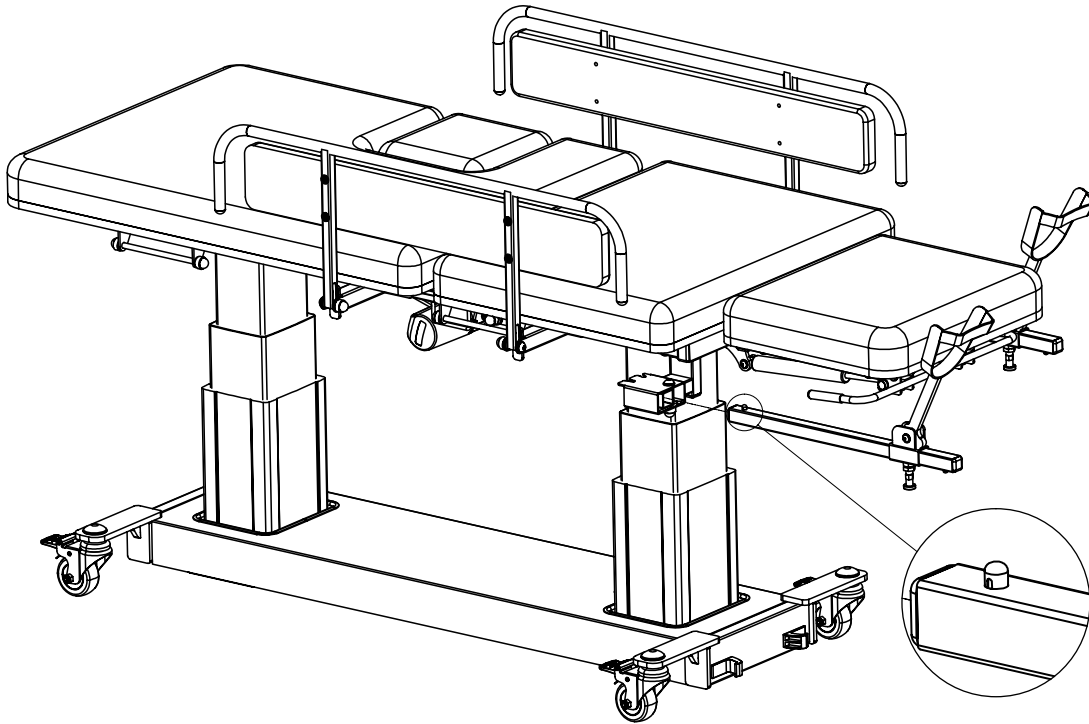

C. Pull up the spring pin, as pictured, to adjust the stirrup distance.

a. Release the pin to lock them into position.

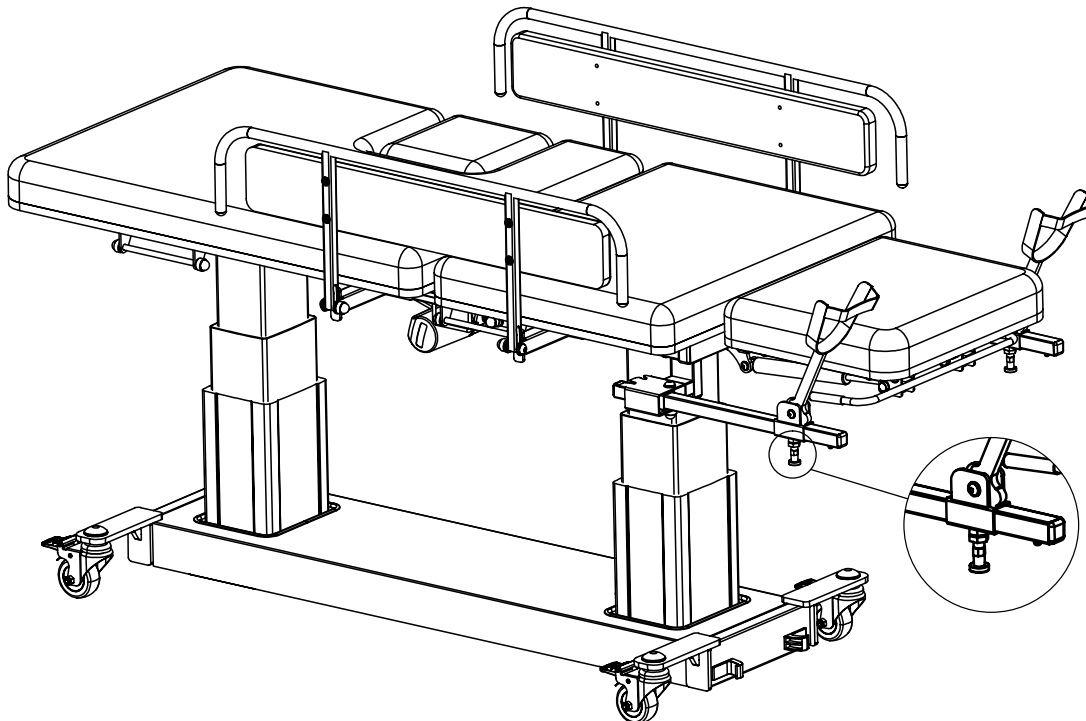

Installation of Side Rails

- A. Align the holes in the guardrail and frame.
- B. Lock the screws to complete the installation.

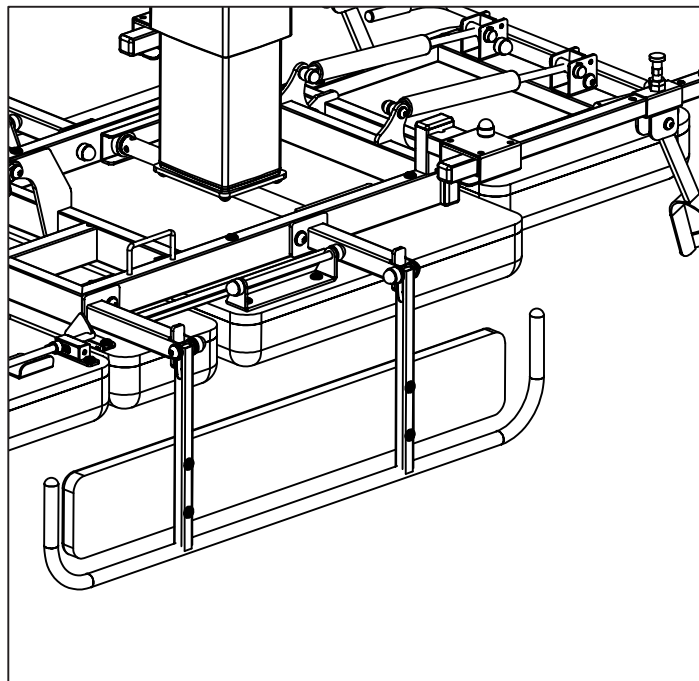
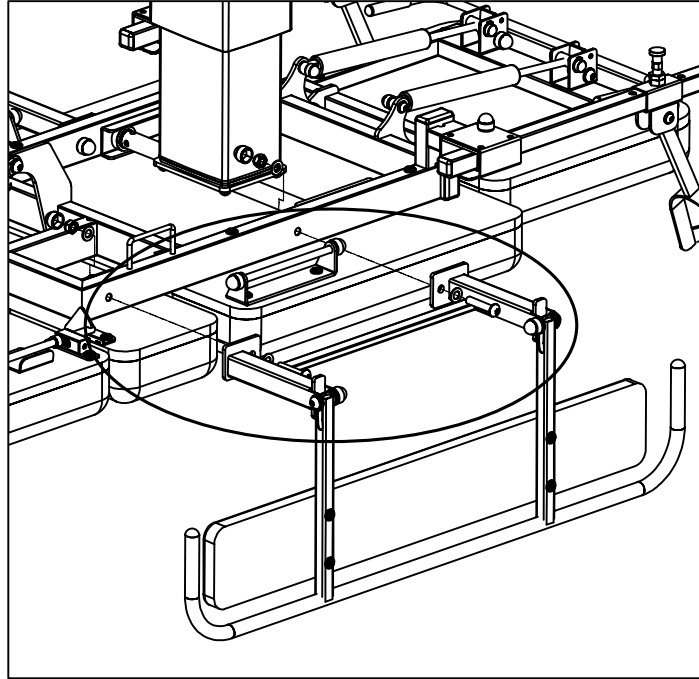

Installation of Paper Dispenser

Step 1:

- A. To install your Paper Roll Dispenser to your exam bed, take it out of the package and lay on a flat surface.
- B. Unscrew the two wing nuts from the bolts on the attachment.

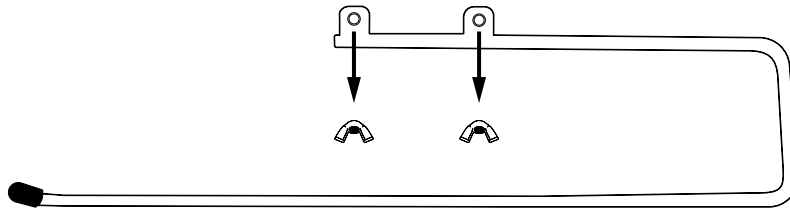

Step 2:

- A. Thread the bolts through the two holes in the front of your exam bed.
- B. Screw the two wing nuts onto the bolts and tighten.

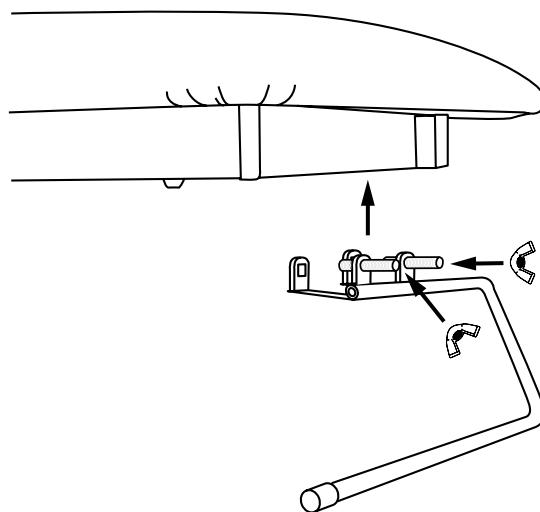

Step 3:

- A. Add your exam paper roll, and you're all set to start using your Paper Dispenser.

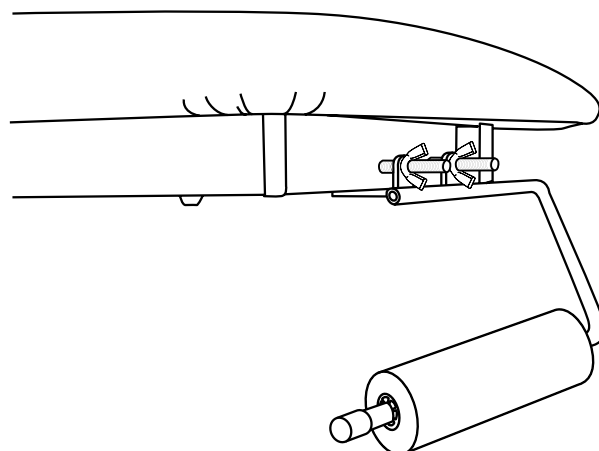

Troubleshooting

If, during the life of the table, you detect any malfunction or need a repair, contact your dealer and do not use the table until you have received a diagnosis or the table has been professionally repaired.

Maintenance

Carry out a visual inspection at least once a month to check the general condition of the table.

Moreover, you must do the following:

1. Check the correct adjustment of the different sections.
2. Check the proper functioning of the motors and their movements.
3. Check and clean the gas struts.
4. Check and tighten screws (if necessary).
5. Grease the parts with friction.
6. Check the conditions of the electrical wiring and the socket.
7. Check the wheel immobilization system.

Recycling

If you need to dispose of the table or any of its parts or accessories, consult and respect the laws and regulations applicable to waste management and protection of the environment.

Cleaning and Disinfecting

Before cleaning the table, unplug it from its power source..

1. Clean the table after each use.
2. Dust the table with a soft, dry cloth.
3. To clean the upholstery, apply a solution of warm water and a mild detergent (for example, neutral soap) with a well-wrung soft cloth.
 - o Wipe the table over once cleaned.
4. Disinfect upholstery and other surfaces with a suitable bactericide for this purpose.
 - o Apply the disinfectant on a soft cloth, never directly on the table.
5. Never use a mixture of disinfectants or a mixture of disinfectant and soap.
6. Wipe the table upholstery over once cleaned & disinfected with a cloth and water only.
 - o This will remove any residue from the upholstery.
7. Avoid the accumulation of moisture on the moving parts of the metal structure, as they could rust.
8. Since we do not know which disinfectant will be used, we cannot guarantee that it will not cause damage to the upholstery.
 - o Read the instructions and warnings for the use of the disinfectant product carefully before its purchase or use.

Transportation and Storage Conditions

Transportation

- The products can be transported by general means of transportation.
1. They should be protected from the sun and rain.
 2. They should not be mixed with toxic, harmful, and corrosive materials.

Storage

- A. The packed electric multifunctional physiotherapy bed should be stored in a dry, well-ventilated environment without corrosive gas.

Shutdown Procedure

- A. Adjust the bed to a suitable storage position without a patient, then turn off the power.
- B. Unlock the wheels if you need to move the table to a different room for storage, and then lock them once it's been moved.

Contraindication

- * Please note that our beds are not sterilized. Please do not use them according to aseptic standards.

Warranty

1. Viva Comfort (the "Company" or "Tiger Companies") warrants to the purchaser that the product will be free from defects in workmanship and materials for a period of 3 years from the date of purchase. The warranty period is not extended if we repair, replace, exchange, or provide a refund for the product (as determined in our sole discretion). We may change the availability of this limited warranty at our discretion, but any changes will not be retroactive.
2. These warranties are not assignable or transferable to any other person, including, without limitation, any subsequent owner or other transferee of the product.
3. This Warranty does not apply to: (a) damage caused by misuse, tampering, abuse, neglect, or accident; (b) damage caused by improper installation, modification, or service; (c) alteration of the serial number; or (d) use that violates the instructions furnished by the Company will void this warranty.
4. The sole responsibility of the Company shall be limited to (a) the repair or replacement (in its sole discretion) of any component of the product which fails to conform to this; (b) a refund the purchase price of such product (in its sole discretion), at no cost to the purchaser for the period of the warranty, or (c) an exchange for a similar product, comparable in function and price.
5. Contact the Company directly at 1-(800)-805-1790 to obtain service under this warranty. If it becomes applicable to send a defective product to the Company, a Return Authorization Number must first be obtained from the Company. In order to obtain service under this warranty, purchaser may be required to provide the Company with the following items (a) proof of purchase, (b) photographs and or videos (of the damage, and (c) a written testimonial describing the defect.
6. Products shipped without prior Return Authorization and Return Authorization Number may not be accepted, and the Company will not be responsible for their disposition and/or cost of return to the owner.
7. The Company will not assume any responsibility for any loss or damage incurred in shipping and or delivery.
8. The product(s) must be returned within 14 calendar days of receiving the return authorization from the Company and must include the original proof of purchase for the warranty to be honored.
9. Any implied warranties that the purchaser may have are limited to the duration of the warranties described above. There are no further warranties that extend or apply beyond the face hereof, and the Company expressly disclaims and excludes any and all warranties of merchantability or fitness for a particular purpose. Some states do not allow limitations on how long an implied warranty lasts, so the above limitation may not apply to you.
10. THE REMEDIES DESCRIBED ABOVE ARE YOUR SOLE AND EXCLUSIVE REMEDIES AND THE COMPANY'S ENTIRE LIABILITY FOR ANY BREACH OF THIS LIMITED WARRANTY. OUR LIABILITY SHALL UNDER NO CIRCUMSTANCES EXCEED THE ACTUAL AMOUNT PAID BY YOU FOR THE DEFECTIVE PRODUCT, NOR SHALL WE UNDER ANY CIRCUMSTANCES BE LIABLE FOR ANY CONSEQUENTIAL, INCIDENTAL, SPECIAL OR PUNITIVE DAMAGES OR LOSSES, WHETHER DIRECT OR INDIRECT. SOME STATES DO NOT ALLOW THE EXCLUSION OR LIMITATIONS OF INCIDENTAL OR CONSEQUENTIAL DAMAGES, SO THE LIMITATION MAY NOT APPLY TO YOU.
11. This warranty gives you specific legal rights, and you may also have additional rights which vary from state to state.

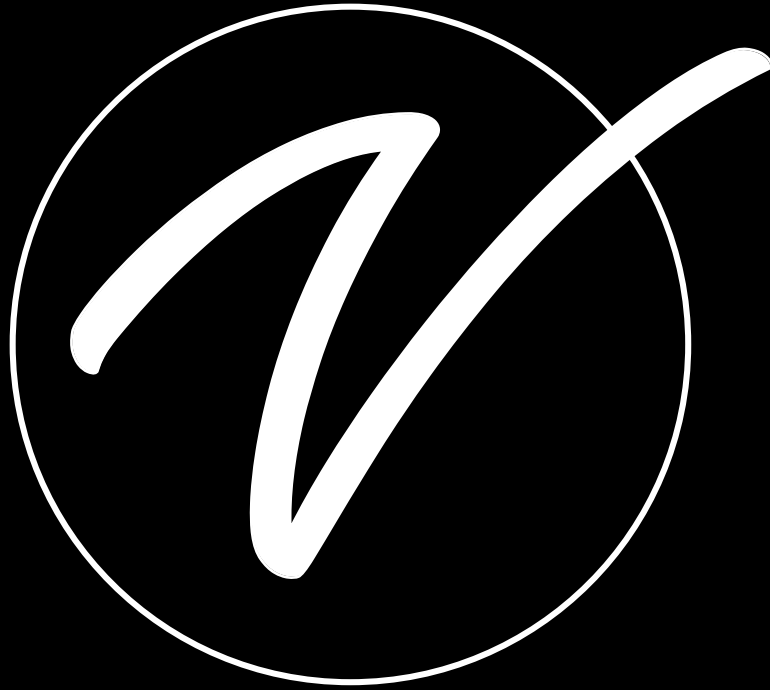

ADI903-04

© 2025 Viva Comfort

vivacomfort.com