



Q4 2024

PRODUCT CATALOG



LEADING THE WAY IN HEALTHCARE SOLUTIONS

At Viva Comfort, we are the vanguards of contemporary medical equipment, bridging critical gaps in the industry with our innovative and modern solutions.

Our cutting-edge solutions set new standards for design, comfort, and care, and redefine the essence of patient-centric healthcare. Embrace a revolution in luxury with Viva Comfort, where excellence, durability, and innovation provide unparalleled medical solutions.



Viva
COMFORT

PRODUCT CATEGORIES

3 Pointe Exam Tables

6 Grande Exam Tables

11 Noble-Line Treatment Tables

17 Regal-Line Rehab Tables

19 Elite-Line Power Treatment Tables

26 Imaging Power Table

30 Physical Therapy Equipment

34 Carts

38 Exam Room Cabinets

PRODUCT CATEGORIES

49 Medical Scales

59 Exam Stools

62 Blood Drawing Chairs

67 Height Measuring Rods

69 Glove Dispensers

74 Sharps & Needle Disposal Containers

80 Pill Crusher

82 Exam Room Packages

POINTE EXAM TABLES



POINTE POWER EXAM TABLE

- Dimensions:
55.12" L X 28.35" W X 18.11" – 33.46" H
- Overall Length with Footrest: 72.12" L
- Mattress Dimensions: 2" H X 28" W X 58" L
- Weight Capacity: 450 lb
- Input 24-29VDC max: 4.8A
- Max load: Push 6000N
- Duty cycle: 10% Max.2 min operate/18min stop

- Compliant with ADA Standards
- Adjustable back and seat sections
- Handheld remote and foot pedal for electric height adjustment
- Enhance adaptability with a gas spring-controlled backrest
- Manual-controlled seat rest
- Pull-out leg rest
- Accessible paper roll dispenser
- Front-facing storage drawer
- Additional storage space behind the backrest
- Easy-to-clean pull-out basin
- Antimicrobial upholstery



BLACK

ADI996-10-BLK



MIDNIGHT EXPRESS

ADI996-10-BLU

**Angle
Adjustment range:**
0° ~ 70°

**Height
Adjustment range:**
18.11" – 33.46"



Pull-Out Basin
12" L x 9.5" W

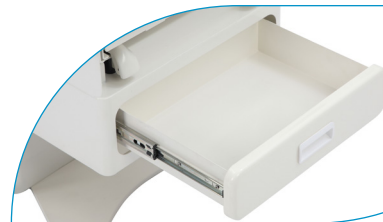

Storage Drawer
12" L x 16.75" W x 4" H



6

GRANDE EXAM TABLES



GRANDE STEEL EXAM TABLE

With Mattress

- Base Dimensions: 29" H X 27" W X 48" L
- Length with Leg Rest Extended: 72" L
- Mattress Dimensions: 2" H X 28" W X 58" L
- Total Weight: 200 lb

- Adjustable backrest
- Pull-out step stool
- Dual-sided cabinet
- Stirrups with contoured heel cups (sold separately)
- Includes paper roll dispenser and paper cutter
- Storage space for paper rolls under the mattress
- Stainless-steel frame for longevity and easy cleaning
- Antimicrobial mattress provides a hygienic environment
- Two-drawer set gives ample space to hold medical supplies



MIDNIGHT EXPRESS

ADI996-09-M-BLU
Mattress



BLACK

ADI996-09-M-BLK
Mattress



Base

ADI996-09-BASE

8 Grande Exam Tables

Pneumatic Adjustment

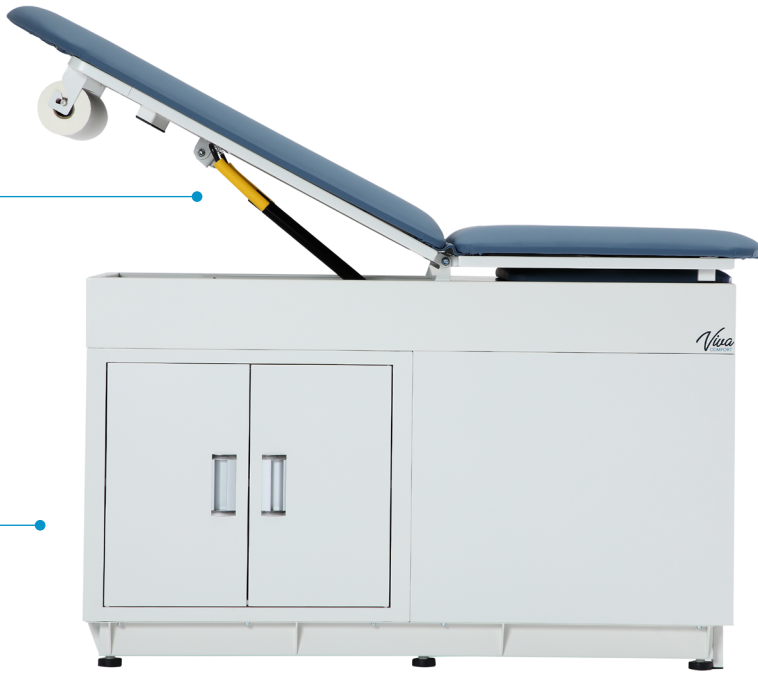

Two-Storage Shelves

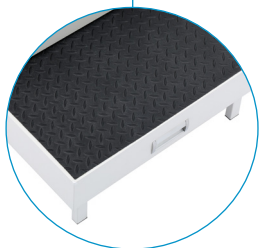

Pull-Out Step Stool

Stirrups
ADI996-09-SU
Sold separately

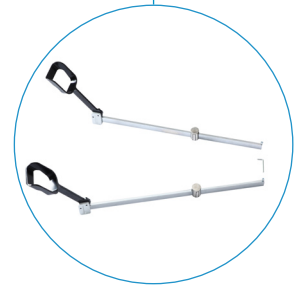

Paper Roll Storage



GRANDE STEEL EXAM TABLE

With Premium Contoured Mattress

- Premium mattress design conforms to the natural shape of a patient’s body
- Contoured mattress provides pressure relief
- Mattress Dimensions: 2” H X 28” W X 58” L
- Total Weight: 205.75 lb



BLACK

ADI996-09-M2-BLK
Premium Mattress



MIDNIGHT EXPRESS





ADI996-09-M2-BLU
Premium Mattress



Base

ADI996-09-BASE



KIT #	DESCRIPTION	INCLUDED SKUs	COLOR
ADI996-09-S2-BLK	Viva Premium Comfort Grande Series Steel Exam Table	ADI996-09-BASE ADI996-09-M2-BLK	Black 
ADI996-09-S2-BLU	Viva Premium Comfort Grande Series Steel Exam Table	ADI996-09-BASE ADI996-09-M2-BLU	Midn. Exp. 
ADI996-09-S-BLK	Viva Comfort Grande Series Steel Exam Table	ADI996-09-BASE ADI996-09-M-BLK	Black 
ADI996-09-S-BLU	Viva Comfort Grande Series Steel Exam Table	ADI996-09-BASE ADI996-09-M-BLU	Midn. Exp. 

GRANDE STEEL EXAM TABLE

With Stirrups

- Included stirrups
- Stirrups with contoured heel cup
- Easily foldable when not in use



BLACK

ADI996-09-SSU-BLK
Regular Mattress



MIDNIGHT EXPRESS

ADI996-09-SSU-BLU
Regular Mattress



BLACK

ADI996-09-SSU2-BLK
Premium Mattress



MIDNIGHT EXPRESS

ADI996-09-SSU2-BLU
Premium Mattress



NOBLE-LINE TREATMENT TABLES



NOBLE-LINE ADJUSTABLE TREATMENT TABLE

With Paper Dispenser

- Foldable leg design helps provides space-saving storage
- Stainless-steel frame for longevity and easy cleaning
- Includes paper roll dispenser and paper cutter
- Overall Dimensions: 31.5" H X 27.5" W X 75.5" L
- Total Weight: 60 lb
- Adjustable backrest
- Rubber feet help prevent floor scratches
- Antimicrobial mattress provides a hygienic environment



BLACK

ADI996-01-BLK

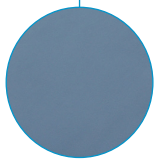

MIDNIGHT EXPRESS

ADI996-01-BLU



SANITATION

Antimicrobial mattress provides safe and hygienic environment, and reduces the risk of cross-contamination

2-INCH PADDED
FOAM PU LEATHER
UPHOLSTERY



FOLDABLE LEGS

KIT #	DESCRIPTION	INCLUDED SKU _s	COLOR
ADI996-01-DR3-BLK	Adjustable Exam Table + Three Drawer Set	ADI996-01-BLK ADI996-01-DR-3	Black 
ADI996-01-DR3-BLU	Adjustable Exam Table + Three Drawer Set	ADI996-01-BLU ADI996-01-DR-3	Blue 

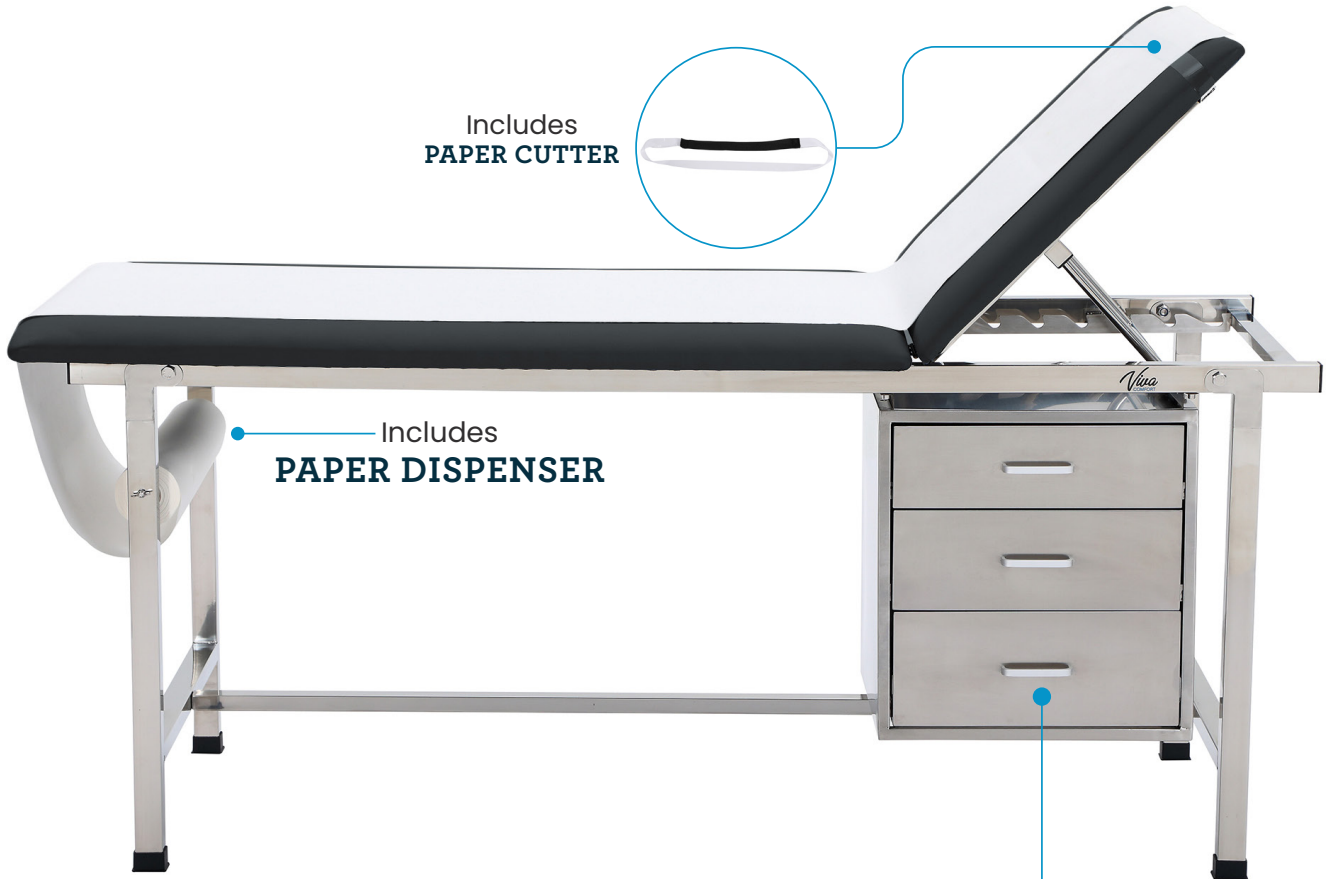

ADJUSTABLE BACKREST

Can be positioned at different heights for the patient's optimal comfort

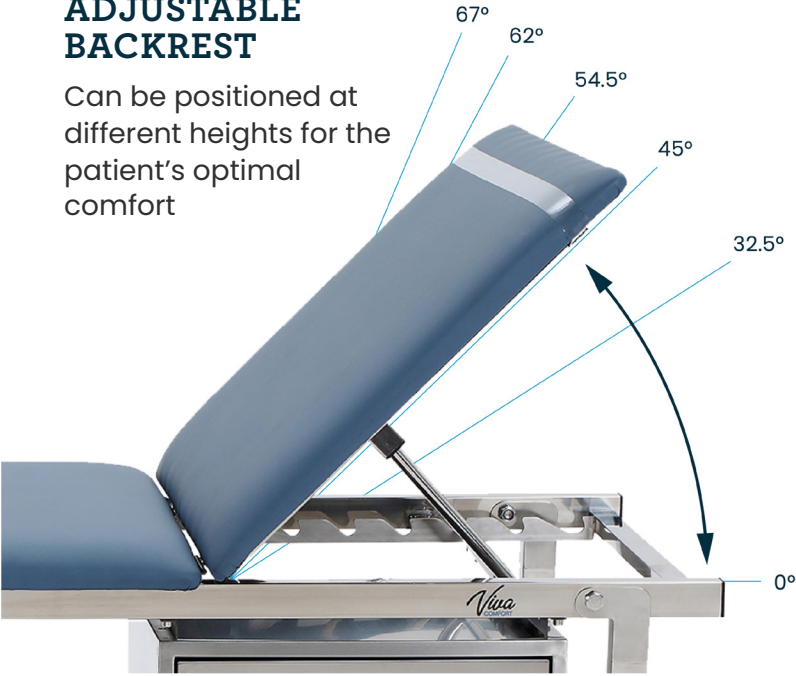

Also available with **3 DRAWER SET**

ADI996-01-DR-3

NOBLE-LINE ADJUSTABLE EXAM TABLE

With Shelf and Exam Paper Roll Dispenser

- Foldable leg design helps provides space-saving storage
- Stainless-steel frame for longevity and easy cleaning
- Includes paper roll dispenser
- Overall Dimensions: 31.5" H X 27.5" W X 74.8" L
- Total Weight: 73.6 lb
- Adjustable backrest
- Rubber feet help prevent floor scratches
- Antimicrobial mattress provides a hygienic environment
- Backrest adjust to angles: 0°, 32.5°, 45°, 54.5°, 62°, and 67°

2-INCH PADDED
FOAM PU LEATHER
UPHOLSTERY

ADI996-02-BLK

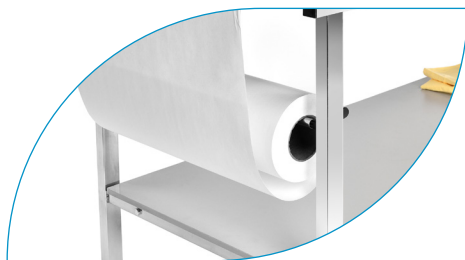

PAPER DISPENSER



AJUSTABLE BACKREST



FOLDABLE LEGS



SHELF

NOBLE-LINE MAHOGANY WOODEN EXAM TABLE

ADI996-03-MA

With Full Shelf

- Equipped shelf provides storage space for various medical equipment
- Wooden frame for longevity and aesthetic appeal
- Integrated paper roll dispenser
- Overall Dimensions: 31.5" H X 28.5" W X 75.5" L
- Total Weight: 112 lb
- Adjustable backrest
- 2-inch padded mattress delivers optimal comfort



CONVENIENT

Paper roll dispenser will help reduce the risk of cross-contamination between patients

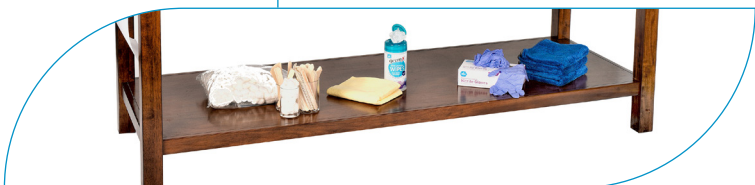

**BUILT-IN SHELF PROVIDES
AMPLE STORAGE**

NOBLE-LINE BLACK STRAIGHT LINE TREATMENT TABLE

- Wooden frame for longevity and aesthetic appeal
- Rounded corner top ensures patients' safety
- 2.25-inch padded mattress delivers optimal comfort
- Overall Dimensions: 31" H X 24" W X 72" L
- Total Weight: 77 lb

ADI996-04-BLK

2.25-INCH PADDED
FOAM UPHOLSTERY



PROTECTION

Rounded corner top to ensure safety and long-term use

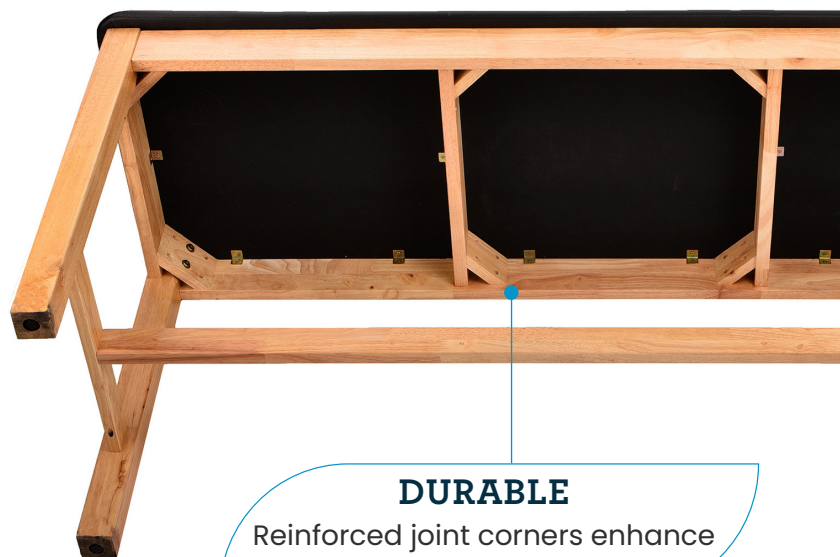
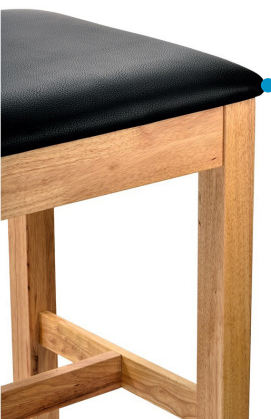

DURABLE

Reinforced joint corners enhance stability and longevity

REGAL-LINE

REHAB TABLES



REGAL-LINE UPHOLSTERED THERAPY REHAB MAT TABLE

- Generous size provides ample space
- Wooden frame for longevity and aesthetic appeal
- Overall Dimensions: 18.5" H X 53" W X 72.5" L
- Total Weight: 99 lb
- 2-inch padded mattress for optimal comfort
- Engineered with a sturdy 6-leg design and center supports

ADI996-05-BLK

2-INCH PADDED
FOAM UPHOLSTERY



STURDY

6-leg design and center supports provides long-lasting strength and durability.



BOTTOM STRUCTURE



ELITE-LINE

POWER TREATMENT TABLES



ELITE-LINE OPEN BASE POWER EXAM TABLE

3-Section

- Overall Dimensions:
18.89"-35.4" H X 26" W X 77" L
- Total Weight: 145.5 lb
- Motor Quantity: 1 motor, 6000N
- Motor Voltage: 110v

- Built-in face cutouts
- Hands-free height adjustment
- Adjustable feet for uneven surfaces
- Hi-lo function can be located from all four sides
- Foot release caster system makes it easy to move
- Antimicrobial upholstery can be easily sterilized
- Gas spring system for back and head adjustment
- Removable stirrups sold separately



ADI903-01



MIDNIGHT EXPRESS



Stirrups Removable

ADI903-01-STIRR



ADI903-PAPER

PAPER ROLL ATTACHMENT



Removable Face Cutout
Provides unobstructed breathing



Foot Release Caster System
Makes the table mobile or stationary



Hands-Free Height Adjustment
With the use of the foot bar

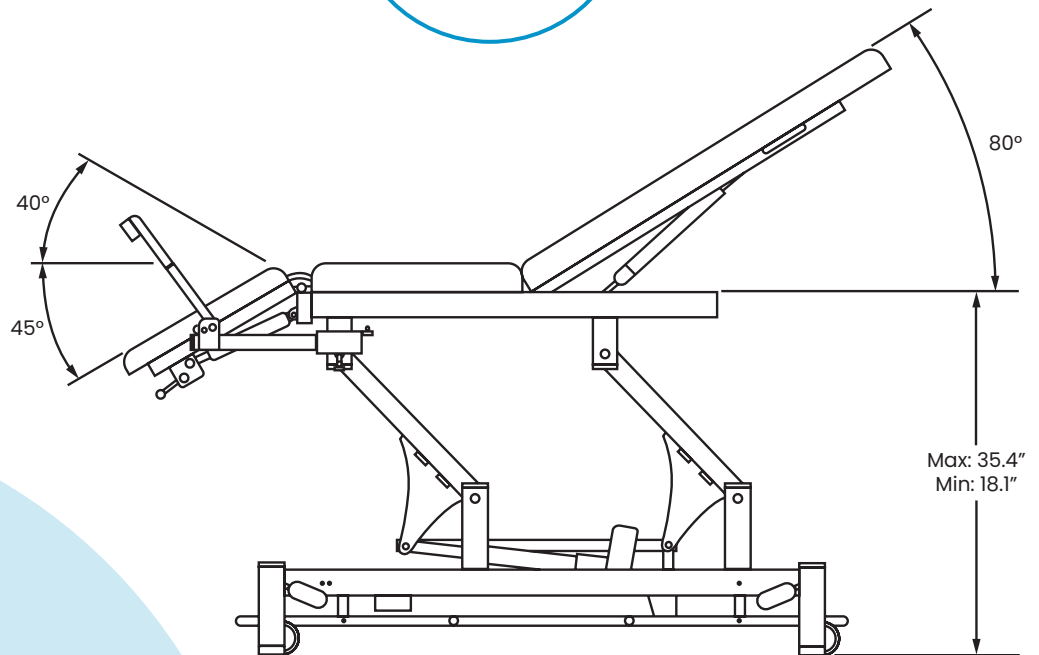

STIRRUP

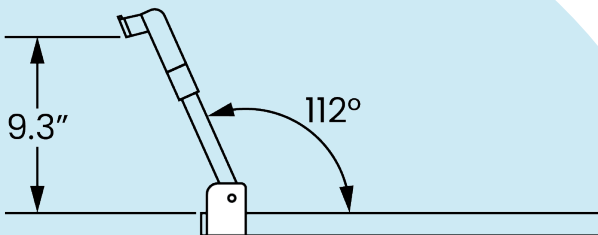

ELITE-LINE HI-LO POWER MAT THERAPY TABLE

- Overall Dimensions: 18.89"– 36.61" H X 47" W X 75" L
- Total Weight: 210 lb
- Motor Quantity: 1 motor, 8000N
- Motor Voltage: 110v

- Extra-wide size
- Includes guard rails
- Built-in face cutouts
- Hands-free height adjustment
- Adjustable feet for uneven surfaces
- Hi-lo function can be located from all four sides
- Foot release caster system makes it easy to move
- Antimicrobial upholstery can be easily sterilized

ADI903-02



GUARD RAILS

Straightforward side rail design enables quick installation of the safety rails



ADA COMPLIANT



450 LB CAPACITY



MIDNIGHT EXPRESS

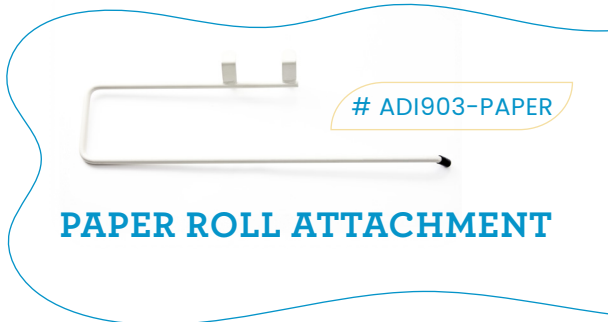

ADI903-PAPER

PAPER ROLL ATTACHMENT



Removable Face Cutout

Provides unobstructed breathing



Hands-Free Height Adjustment

With the use of the foot bar



Foot Release Caster System

Makes the table mobile or stationary

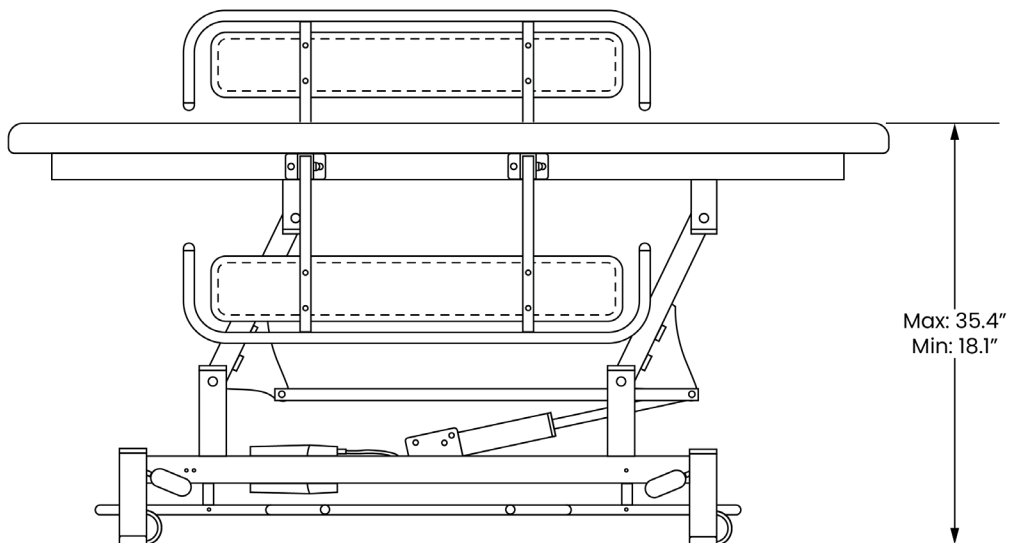

ELITE-LINE HI-LO POWER TREATMENT TABLE

With Padded Side Rails

- Overall Dimensions: 18.89" - 36.6" H X 26" W X 70" L
- Total Weight: 142 lb
- Motor Quantity: 1 motor, 6000N
- Motor Voltage: 110v

- Includes guard rails
- Built-in face cutouts
- Hands-free height adjustment
- Adjustable feet for uneven surfaces
- Hi-lo function can be located from all four sides
- Foot release caster system makes it easy to move
- Antimicrobial upholstery can be easily sterilized

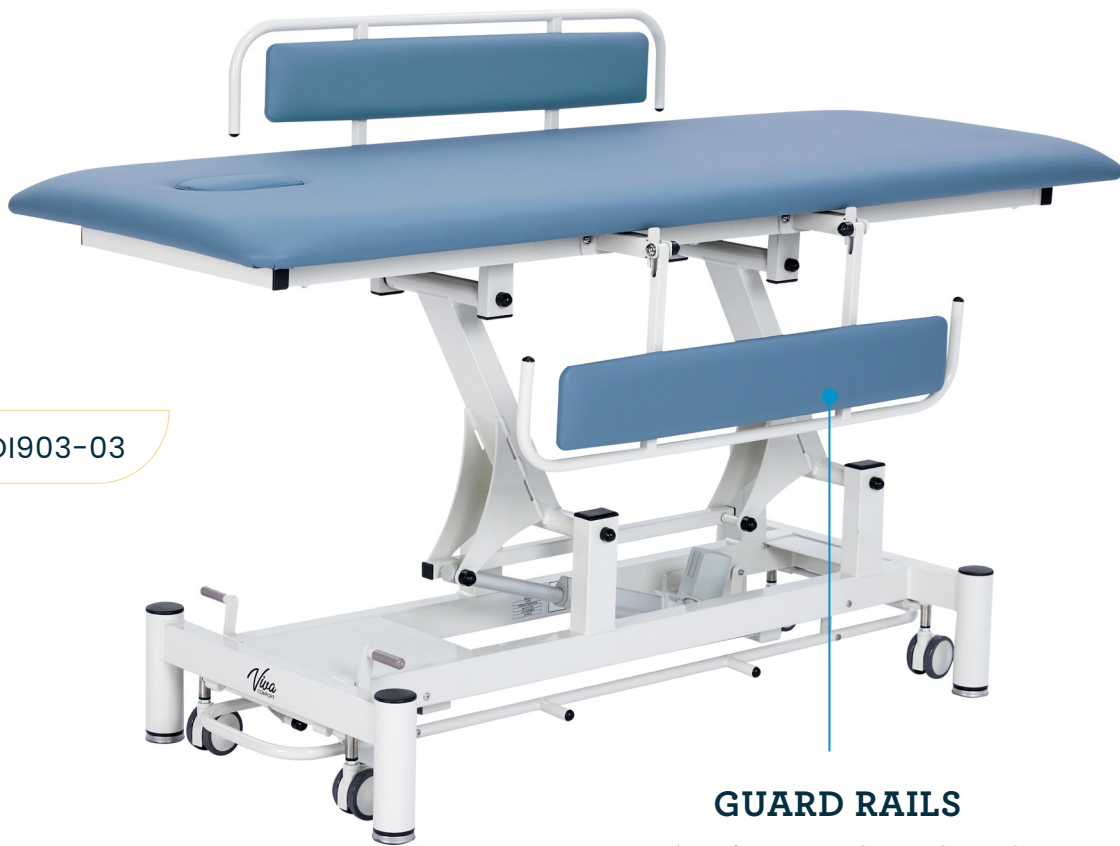

ADI903-03



ADA COMPLIANT



550 LB CAPACITY

GUARD RAILS

Straightforward side rail design enables quick installation of the safety rails

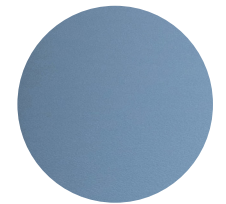

MIDNIGHT EXPRESS



ADI903-PAPER

PAPER ROLL ATTACHMENT



Removable Face Cutout

Provides unobstructed breathing

Foot Release Caster System

Makes the table mobile or stationary

Hands-Free Height Adjustment

With the use of the foot bar

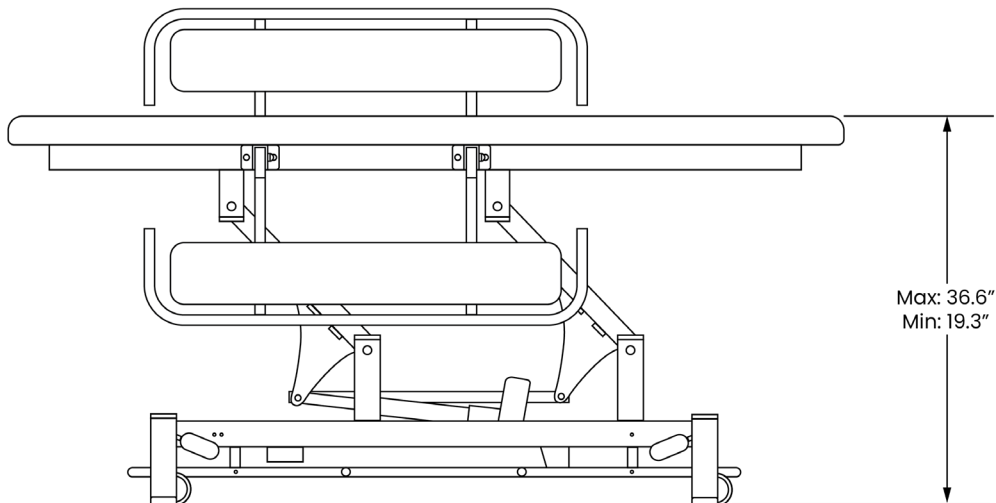

26

IMAGING POWER TABLE

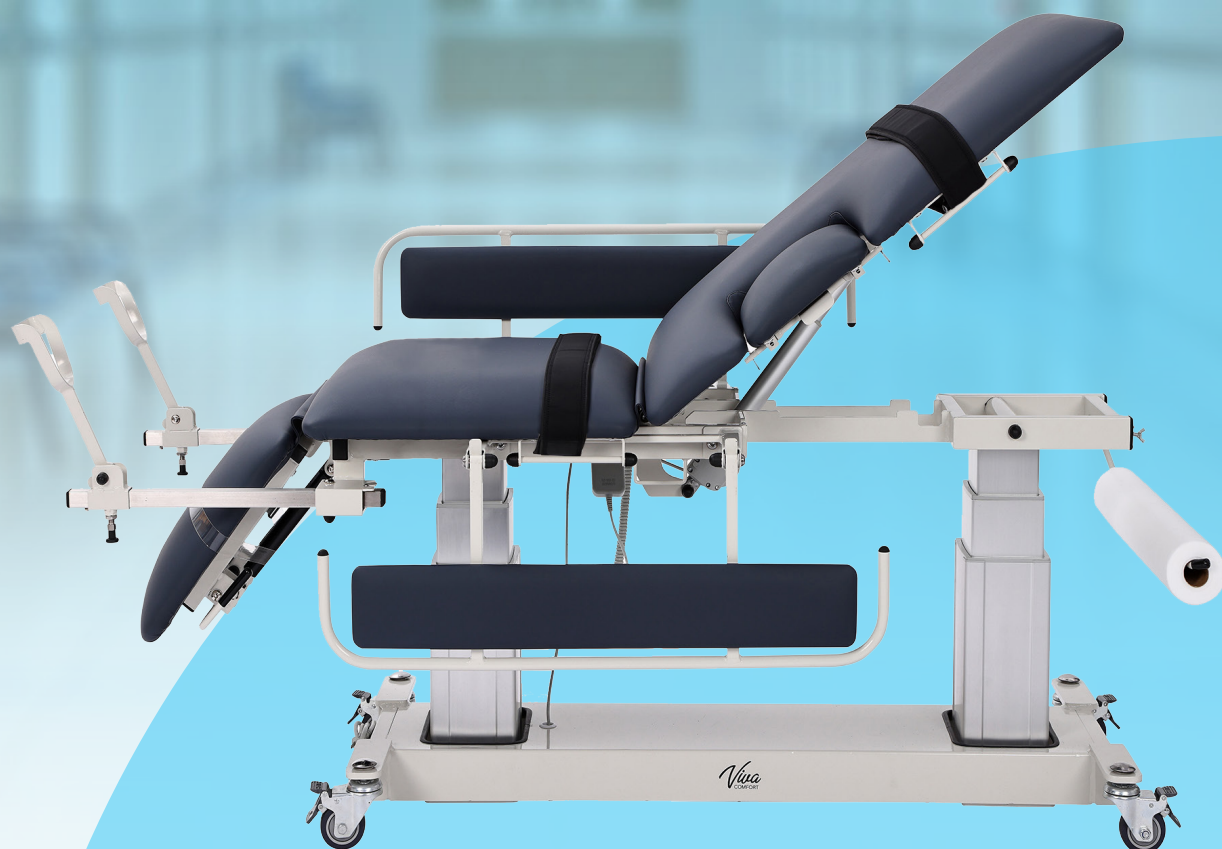

ELITE-LINE MULTI-USE IMAGING POWER TABLE

With 3-Section Top & Drop Window

- Manual footrest
- Heavy-duty wheels
- Antimicrobial upholstery
- Pneumatic adjustable backrest
- Remarkable weight capacity of 550 lbs
- 10" x 10" drop window to enhance accessibility
- Easy-to-use hand control for height adjustments
- All-welded base and top frame, equipped with a dual-column lift system
- Additional accessories available



BLUE

ADI903-04



1,100 LB STATIC
WEIGHT
CAPACITY

550 LB
DYNAMIC
WEIGHT
CAPACITY

- Overall Dimensions: 21.45"–37.2" H X 27.5" W X 77" L
- Total Weight: 242 lb
- Motor Quantity: 2 Column Motor, 1 Single Line
- Column Motor: 4000N, and 1 Double Line
- Column Motor: 4000N
- Motor Voltage: 110v
- Watts: 400VA
- Motor Certification: CE, ETL
- Padding: 3" thick high-density foam

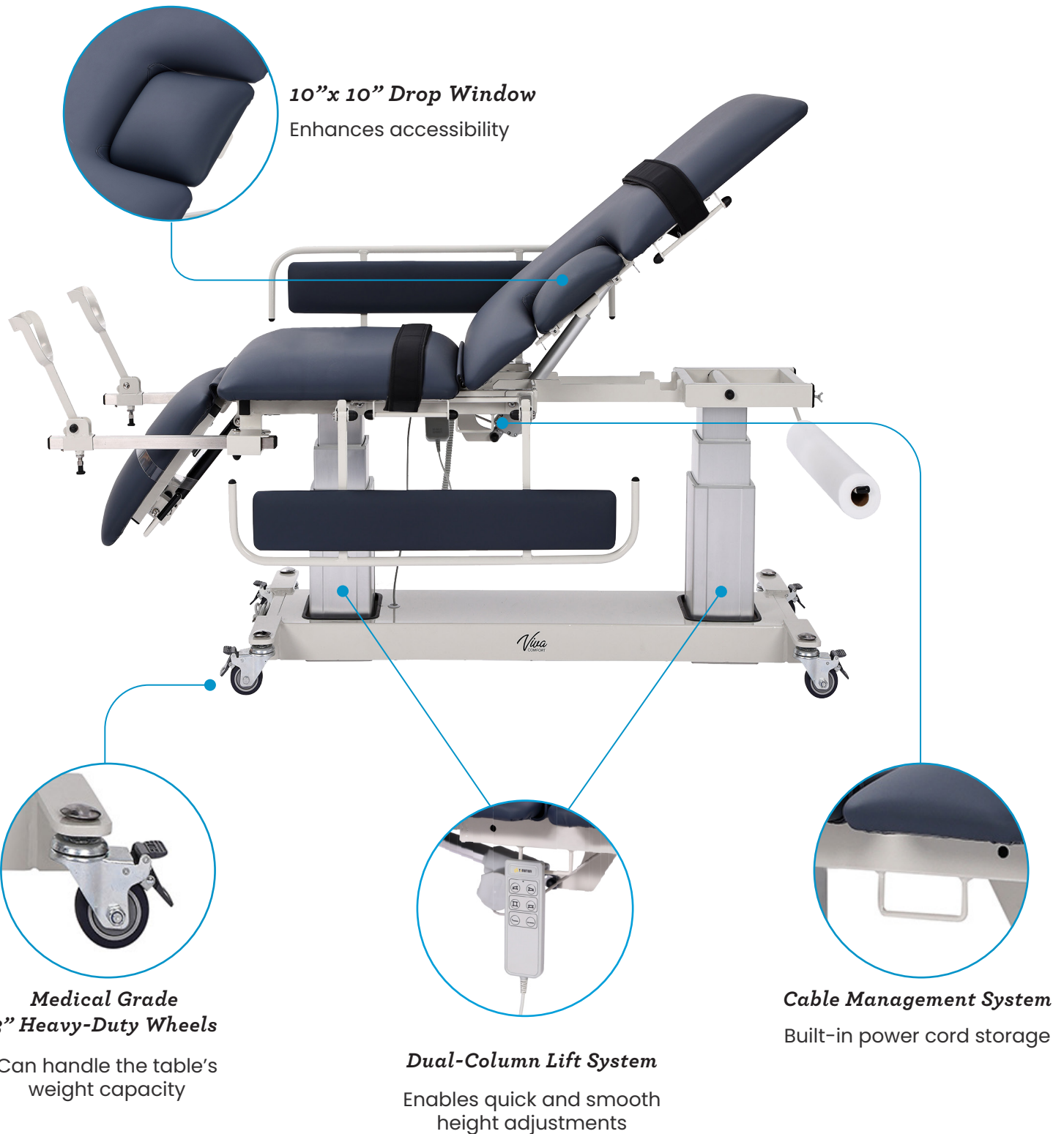

- Offers Trendelenburg and Reverse Trendelenburg angles of +20° to -20°
- Leg section and backrest adjustments of up to 80°



Trendelenburg



Reverse Trendelenburg



Supine

AVAILABLE ACCESSORIES:



ADI903-04-PA



ADI903-04-RA



ADI903-04-SS



ADI903-04-STIR



Trendelenburg



Reverse Trendelenburg



Supine

PHYSICAL THERAPY EQUIPMENT



FOLDING PARALLEL BARS

7 feet

- Overall Dimensions: 28" - 41" H X 16" - 23.8" W X 83.9" L
- Total Weight: 123 lb
- Qty of Height Adjustment Holes: 14
- Height Increments: 0.59"

- Includes guard rails
- Foldable, space-saving design
- Square telescoping steel uprights
- 1-1/2" one-piece stainless-steel handrails
- End bumpers on the ends of each handrail
- Double stiffening rails ensure unmatched stability
- Built-in height knob eliminates unwanted movement
- Width can be easily adjusted to suit user preferences

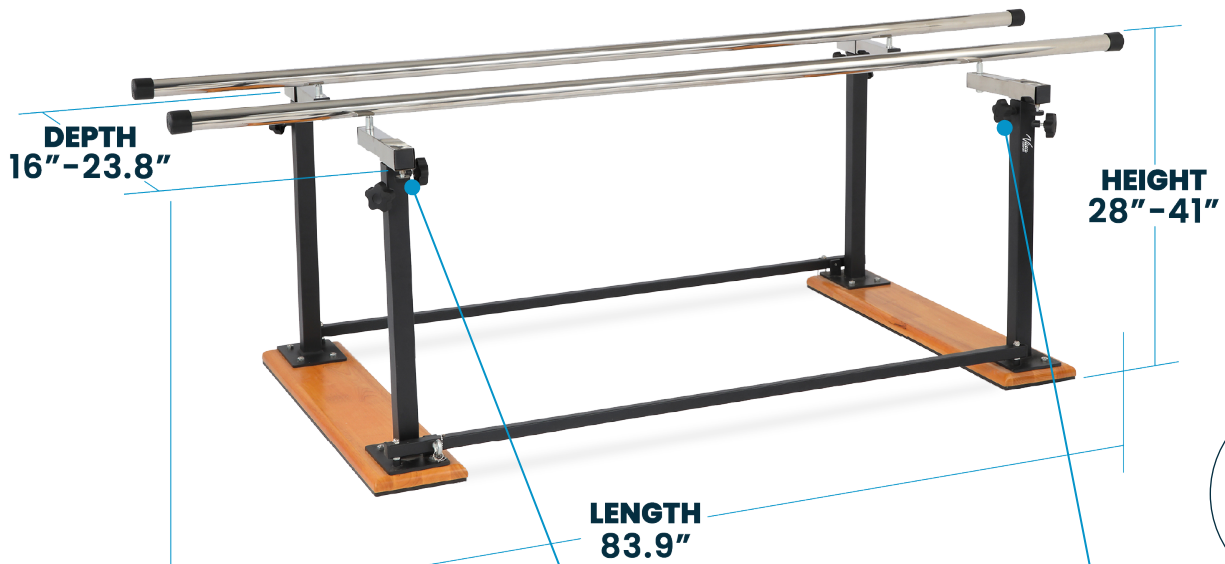

ADIME905-01

SPACE-SAVING
Easily fold and store them when not in use

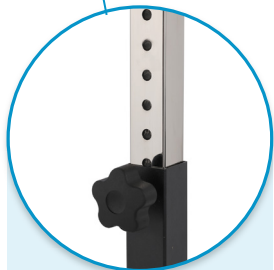

Built-In Height Knob
28" - 41"
Hole Distance
0.6"



Width Adjustable
16" - 23.8"

SMALL UP & DOWN STAIRCASE

- Includes guard rails
- Hardwood plywood base
- Overall Dimensions: 47.6" H X 54.7" W X 33" D
- Total Weight: 100 lb
- Platform Dimensions: 11.81" H x 29.92" W x 23.23" D
- 1 Step Dimensions: 5.91" H x 29.92" W x 9.84" D
- 2 Step 1st Step Dimensions: 3.94" H x 29.92" W x 9.84" D
- 2 Step 2nd Step Dimensions: 5.91" H x 29.92" W x 9.84" D

- Two different step height options
- Powder-coated steel uprights and brace-reinforced underside
- Crafted with steel fasteners and metal braces
- Four full-width pieces of safety tread on the platform
- Two full-width pieces of safety tread on each step
- One-piece handrail support system ensures a secure grip

ADIME906-01



NON-SLIP

Full-width tread provides ultimate safety for patients

THERAPY SHOULDER CONDITIONING FINGER LADDER

2 Pack

- Overall Dimensions: 54" H X 2" W X 1" D
- Total Weight: 2.2 lb

- Lightweight material
- Made from premium, mold-resistant pine wood
- Designed to help patients regain mobility and strength due to injury

ADI910-01-2



REHABILITATION

Excellent therapeutic instrument for
shoulders, wrists, and elbows

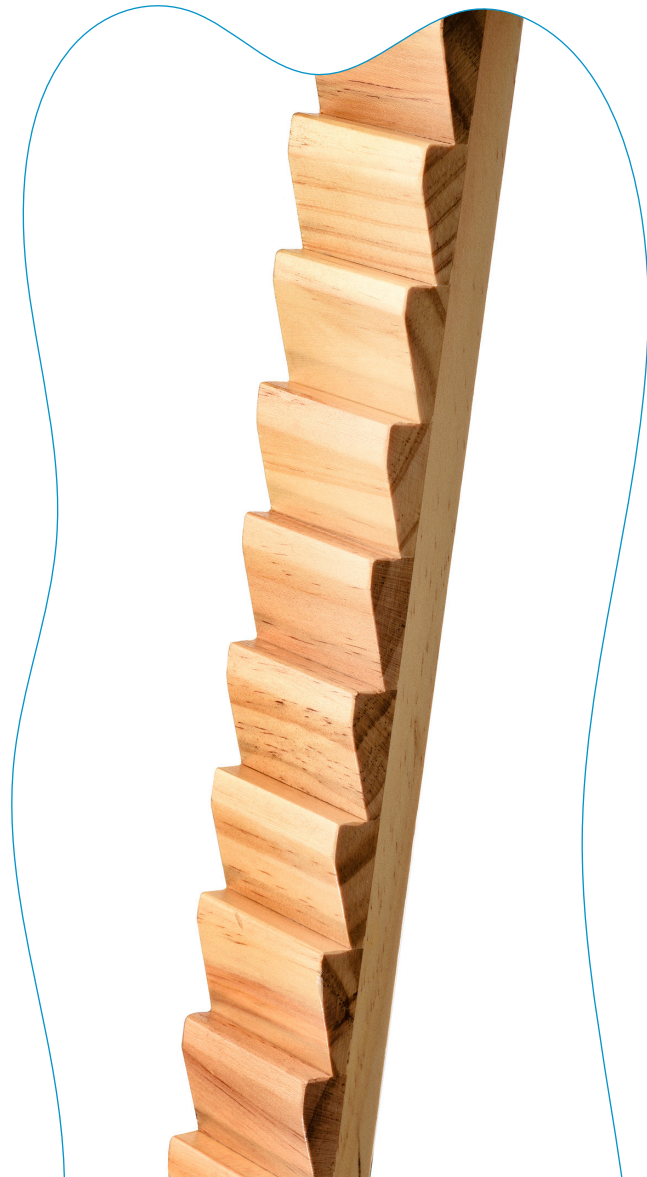

CARTS



UNIVERSAL MOBILE CART

Without Mounting Plates

- Seamlessly integrates with various monitoring systems
- Integrated cord organizer keeps cables tidy
- Overall Dimensions: 31.4"H x 22.5" D
- Total Weight: 22.04 lb

ADJUSTABLE

Telescoping pole offers a height range of 31.49" to 51.18"

ADIME912-C

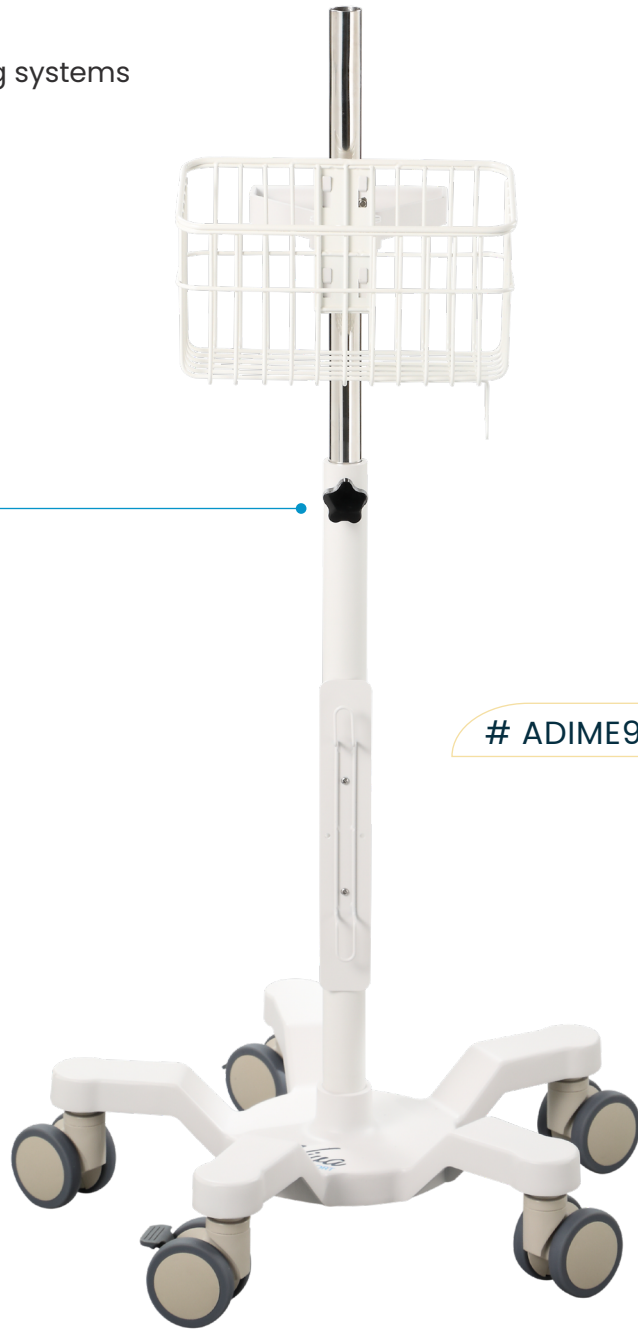

INCLUDED

Wire basket provides storage space





**For Welch Allyn
Connex Spot Monitor**

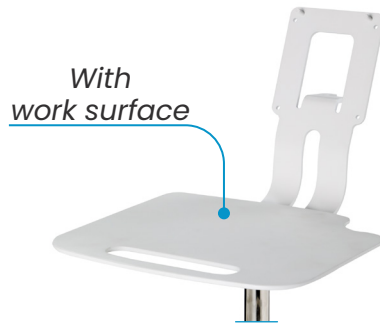

*With
work surface*

**For Welch Allyn
Connex Spot Monitor**



For Edan Monitor



**For RVS-100
Vital Signs Monitor**



**For Covidien
PM10N Series Monitor**

KIT #	DESCRIPTION	WEIGHT	DIMENSIONS
ADIME912-C-MP-01	Universal Mobile Cart + Welch Allyn Connex Mounting Plate	27.11 lb	8.27" L x 11.22" W x 11.61" D
ADIME912-C-MP-02	Universal Mobile Cart + Welch Allyn Connex Mounting Plate With Work Surface	27.11 lb	8.27" L x 11.22" W x 11.61" D
ADIME912-C-MP-03	Universal Mobile Cart + Edan Monitor Mounting Plate	26.01 lb	9.84" L x 4.78" W x 9.84" D
ADIME912-C-MP-04	Universal Mobile Cart + RVS-100 Vital Signs Monitor Mounting Plate	26.01 lb	9.84" L x 4.78" W x 9.84" D
ADIME912-C-MP-05	Universal Mobile Cart + Covidien PM10N Series Mounting Plate	26.01 lb	9.45" L x 4.17" W x 9.45" D



MOBILE STAND

for Welch Allyn 4400
Vital Signs Monitor

- Easy to clean surface ensures optimal sanitation
- Lifting function to adjust pole height for maximum comfort and accessibility
- Overall Dimensions: 41.73" x 20.47" x 20.47"
- Total Weight: 26.46 lb

ADIME911-01



BASKET

Dimensions: 11.02" x 6.29" x 5.70"



38

EXAM ROOM CABINETS



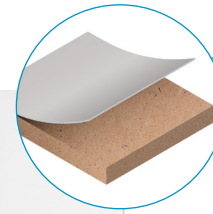

Antimicrobial Laminate

MDF



MATERIAL:

- Constructed from long-lasting MDF material
- Chip-resistant edges that can handle bumps and bangs
- Exclusive antimicrobial high-pressure laminate exterior

FINISH:

Versatile grey finish will seamlessly blend into your medical facility

HARDWARE:

Deluxe soft-closing drawer rails and door hinges are equipped on our wall and base cabinets



36-INCH BASE CABINET

With Left Sink, Right Sink, or No Sink

- Easy-to-clean surfaces
- Modern aluminum handles
- Each cabinet has 3 drawers and 1 door
- Backsplash of 3.125" to protect your walls
- Overall Dimensions: 35.5" H X 36" W X 19" D

- Exclusive antimicrobial high-pressure laminate
- Soft-close hinges and adjustable interior shelves
- Chip-resistant edges can handle bumps and bangs without degrading
- Medical sink that is ideal for regularly disinfecting your hands

Stainless Steel Medical Sink

7.87" x 16.9" x 16.9"

Faucet Style: Gooseneck



Cabinet With Left Sink

#ADIME902-BASE-36-LS-GRY

Cabinet With Right Sink

#ADIME902-BASE-36-RS-GRY

Cabinet With No Sink

#ADIME902-BASE-36-NS-GRY



Soft-Close Hinges

48-INCH BASE CABINET

With Left Sink, Right Sink, or No Sink

- Easy-to-clean surfaces
- Modern aluminum handles
- Each cabinet has 2 drawers and 4 doors
- Backsplash of 3.125" to protect your walls
- Antimicrobial high-pressure laminate
- Soft-close hinges and adjustable shelves
- Chip-resistant edges can handle bumps and bangs without degrading
- Medical sink that is ideal for regularly disinfecting your hands.
- Overall Dimensions: 35.5" H x 48" W x 19" D



Cabinet With Left Sink # ADIME902-BASE-48-LS-GRY



Cabinet With Right Sink # ADIME902-BASE-48-RS-GRY



Stainless Steel Medical Sink
7.87" x 16.9" x 16.9"
Faucet Style: Gooseneck



Cabinet With No Sink # ADIME902-BASE-48-NS-GRY



Soft-Close Hinges

WALL CABINET

36" or 48" Wide

- Easy-to-clean surfaces
- Modern aluminum handles
- Exclusive antimicrobial high-pressure laminate
- Chip-resistant edges can handle bumps and bangs without degrading
- Each cabinet has 2 soft-close hinged doors and 2 adjustable shelves
- 36" Overall Dimensions: 24" H X 36" W X 12" D
- 48" Overall Dimensions: 24" H X 48" W X 12" D

36-Inch

ADIME902-WALL-36-GRY

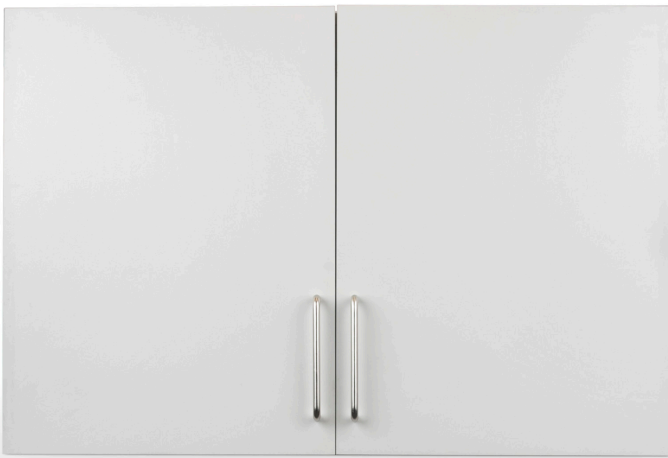

Soft-Close Hinges



4 Internal Shelves



48-Inch

ADIME902-WALL-48-GRY

NON-ALARMED STEEL CABINET

For Defibrillators

- Overall Dimensions: 15" H X 15" W X 7" D
- Total Weight: 10 lb

- Easy-to-clean , long-lasting steel surface
- Large window allows for quick identification
- Single handle, pull door allows for instant access
- Designed to accept most commonly used AED devices
- "Emergency Defibrillator" in bold, red lettering makes it easy to spot during an emergency



Bold, Red Lettering

Easy to spot during an emergency



ADI999-01



LARGE MEDICAL SECURITY CABINET

Dual Locks

- Overall Dimensions: 21" H X 16" W X 6" D
- Total Weight: 10 lb

- Welded steel construction provides corrosion & scratch resistance
- Prioritizes safety with dual locks and separate keys
- Ample storage space for prescriptions and first aid supplies
- Equipped with three large shelves and two mini shelves
- Adorned medical white cross symbol helps to identify the purpose and contents of the cabinet visually

STORAGE

Three full-length shelves for various medical equipment

SUPPLEMENTAL

Two mini shelves for smaller bottles

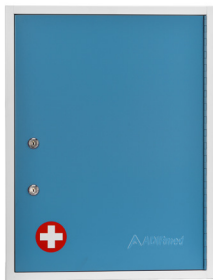

ADI999-04-BLU

BLUE



ADI999-04-WHI

WHITE



ADI999-04-RED

RED



ADI999-04-PUR

PURPLE

LARGE MEDICAL SECURITY CABINET

Dual Locks

- Overall Dimensions: 21" H X 16" W X 6" D
- Total Weight: 10 lb

ADI999-06-WHI

WHITE



ADI999-06-RED

RED



- Outfitted with a handle and four full-length shelves
- Prioritizes safety with dual locks and separate keys
- Welded steel construction provides corrosion & scratch resistance
- Ample storage space
- Door is outfitted with interior pocket for holding medical records and documents
- Convenient pull-out shelf you can pull out when you need additional working space
- Adorned medical white cross symbol helps to identify the purpose and contents of the cabinet visually

STORAGE

Three full length shelves for various medical equipment



OUTFITTED

Pull-out shelf for additional space and built-in interior pocket for documents

LOCKING DRUG CABINET

- Overall Dimensions: 5.9" H X 12.5" W X 6" D
- Total Weight: 2.6 lb

ADI999-05-WHI

- Prioritizes safety with a lock and key
- Compact design requires minimal space
- Welded steel construction provides corrosion & scratch resistance
- Ample storage space for prescriptions, OTC's and first aid supplies
- Adorned medical white cross symbol helps to identify the purpose and contents of the cabinet visually

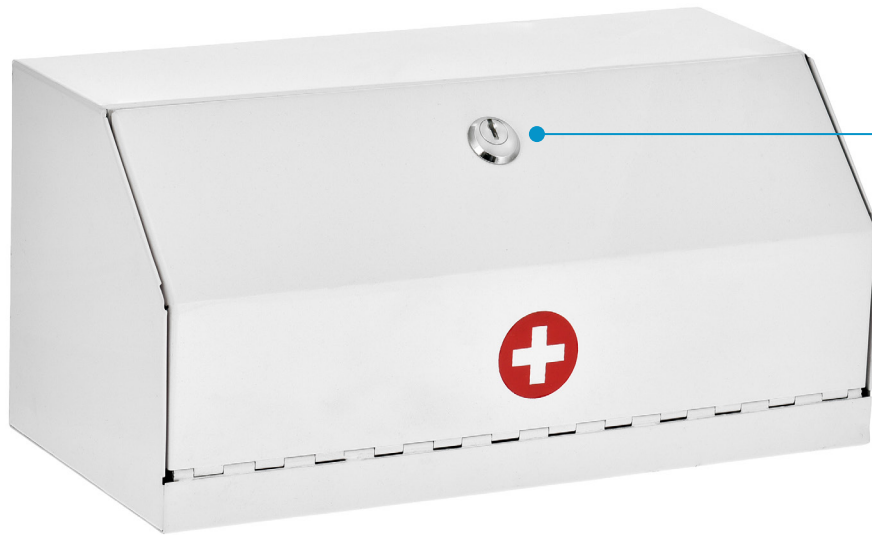

Equipped
Lock and included key help
safeguard the contents of
the cabinet



VERSATILE

Lid can open forward or upward



MOUNTABLE CORNER, LOCKING MEDICAL CABINET

Two Shelves

- Overall Dimensions: 14.01" H x 7.48" W x 7.48" D
- Total Weight: 9.04 lb
- Two shelves to store various medical supplies
- Corner-mountable, compact design
- Two keys to ensure you always have one on hand
- Great for hospitals, clinics, camps, schools, nursing homes, and even residential homes
- Door is adorned with a lock to prevent tampering

ADIME999-01-1

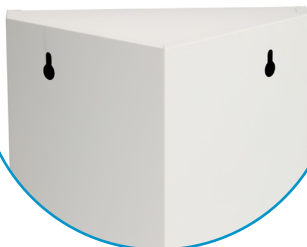

Mounting Holes



SPECIMEN PASS-THRU CABINET

- Overall Dimensions: 12.7" H x 13.2" W x 6" D
- Total Weight: 9.5 lb
- Weight Capacity: 44.09 lb
- Both doors can not open simultaneously, providing optimal privacy
- Crafted from top-tier stainless steel
- Ample room for specimens of various sizes
- Easy-to-clean stainless steel surface
- Included stainless steel tray
- International symbol of a conical flask to help identify the specimen cabinet



ADIME960-01



CONFIDENTIALITY

Affixed springs avoids opening both doors simultaneously

MEDICAL SCALES

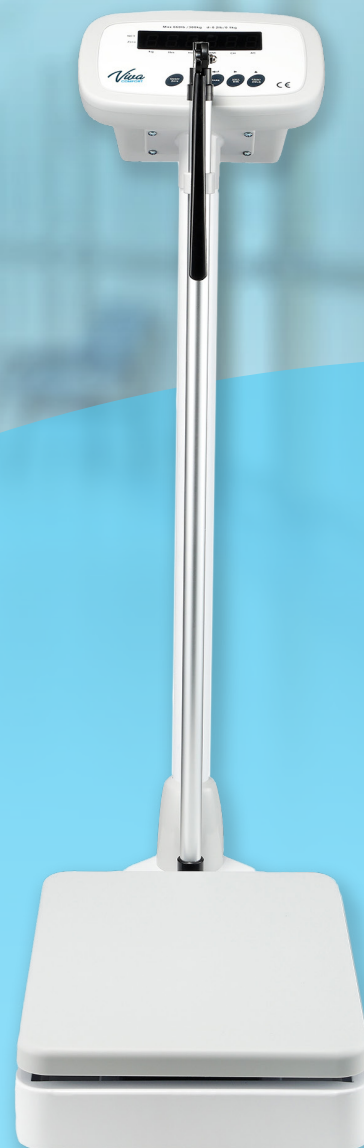

DIGITAL PHYSICIAN SCALE

With Height Rod

- Bright LCD screen
- Easy switch between lbs and kgs
- Hardy metal body to ensure durability
- Equipped with lightweight height rod
- Platform adorned with an anti-slip safety mat
- AC adapter or internal 6V rechargeable batteries
- Easily calculates patient's BMI
- Overall Dimensions: 37" H X 12" W X 20" D
- Height Rod Range: 31.5" to 82.6"
- Overall Weight: 20 lb

ADIME904-01



Bright LCD screen digitally shows your patients' weight in lbs. or kgs.





Digital display shows weight (lbs and kg) and BMI



Lightweight height rod is effortless to maneuver



Hardy metal body ensures its longevity

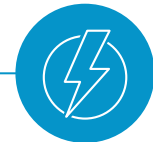

Functions with AC adapter or internal 6V rechargeable batteries



Platform adorned with an anti-slip safety mat

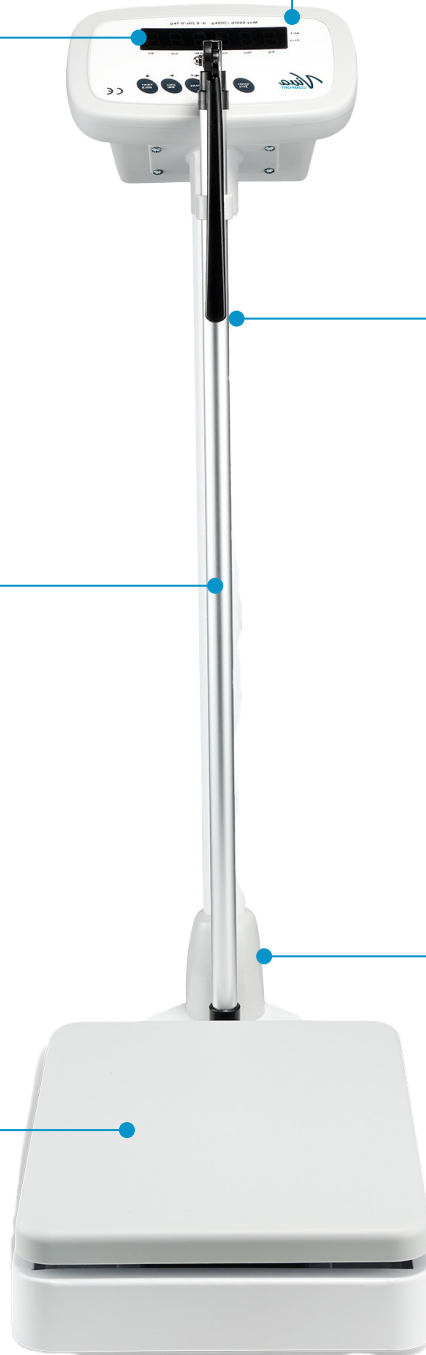

PHYSICIAN BEAM SCALE

With Height Rod

- Hardy metal body to ensure durability
- Equipped with lightweight height rod
- Platform adorned with an anti-slip safety mat
- Dual beams with two easy manual sliding weights
- Two easy gliding wheels to facilitate maneuvers
- Overall Dimensions: 58" H X 14" W X 19" D
- Height Rod Range: 23.6" to 83.8"
- Overall Weight: 35 lb

ADIME904-02

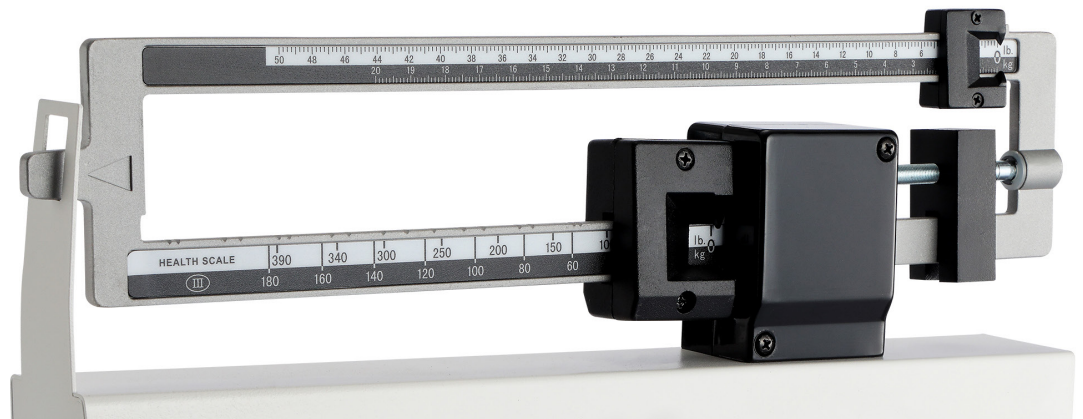



Dual beams with two easy manual sliding weights



Lightweight height rod is effortless to maneuver



Hardy metal body ensures its longevity

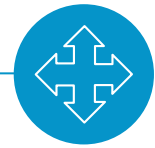

Two easy gliding wheels to maneuver the scale wherever needed

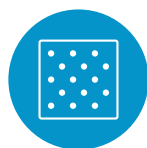

Platform adorned with an anti-slip safety mat

MEDICAL WHEELCHAIR SCALE

- Bright LCD screen
- Easy switch between lbs and kgs
- Hardy metal body to ensure durability
- Handle and wheels make it easy to maneuver
- Adorned with non-slip adjustable leveling feet
- Built-in ramp on both sides allows for easy access
- Overall Dimensions: 32.5" H X 40" W X 48" L
- Overall Weight: 143 lb

ADIME904-03





Accessible

With the included handle and wheels, you can maneuver the scale wherever needed



Durable

Hardy metal body ensures its longevity from continual wear and tear



Stable

Non-slip adjustable leveling feet guarantee a stable platform



Accommodating

Built-in ramp on both sides allows straightforward access to the scale

DISPLAY

Bright LCD screen digitally shows your patients' weight in lbs. or kgs.



STAINLESS STEEL VETERINARY SCALE

- Convenient tare function
- Digital display for fast weight readings
- High-quality stainless steel construction
- Integrated wheels allow for seamless mobility
- Spacious and flat platform design for easy weighing
- Shows weight for up to 10 seconds after removing the animal
- Equipped with accurate load cells and advanced weighing technology
- Suitable for various animals, from pets like cats, dogs, rabbits, and smaller livestock
- Overall Dimensions: 2" H X 20" W X 44" L
- Overall Weight: 44 lb



ADIME904-04



DISPLAY

Bright LCD screen digitally shows your patients' weight in lbs. or kgs.





Precision

Accurate load cells, advanced weighing technology and easy-to-read digital display



Convenient

Tare function allows the deduction of bedding or container weight



Power Saver

Enabled with an auto sleep or power down function to save on battery life



Optional

Interface can be mounted with the bracket, or it can be left unattached



Robust

High-quality stainless steel construction ensures resilience and longevity



Effortless

Spacious platform for easy loading of animals without strain or injury



Transportable

Lightweight and outfitted with a handle, making it simple to move



Accommodating

Suitable for various animals, from pets like cats, dogs, and rabbits to smaller livestock.

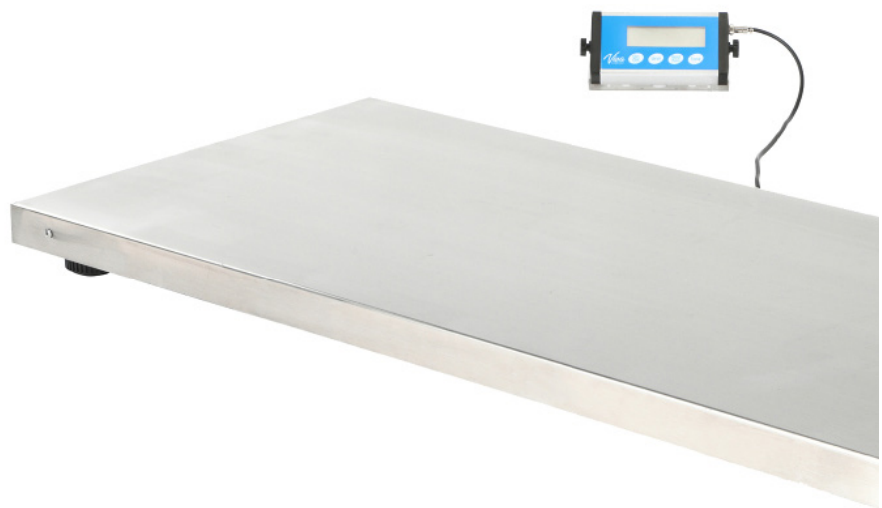

MEDICAL HANDRAIL SCALE

- Dimensions: 51.6" H x 20.47" W x 24.4" D
- Overall Weight: 55.11 lb
- Weight Capacity: 660 lb (300 kg)

- Sturdy stainless steel structure
- Strategically positioned grips for comfort and security
- Low-level platform, only 2.4" from the ground
- Display contains essential operating keys
- Adjustable feet for uneven surfaces
- Two 1.5" wheels for manageable maneuverability
- Accuracy of 0.1 kg/0.2 lb

ADIME904-05



DISPLAY



Bright LCD screen digitally shows your patients' weight in lbs. or kgs.



Ergonomic Handles
For utmost comfort



Adjustable Feet
To keep it stable on uneven surfaces



EXAM STOOLS



PNEUMATIC HEIGHT ADJUSTABLE LUXE EXAM STOOL

- Seat height can be quickly altered
- Thick upholstery padding gives added comfort
- 5-star leg design provides stability when moving
- Smooth rolling wheels can handle carpeting and hard floors
- Overall Dimensions: 19" - 24.6" H X 23" W X 16" D
- Overall Weight: 12 lb

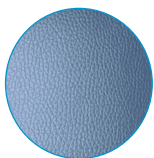

MIDNIGHT EXPRESS

ADI910-01-BLU

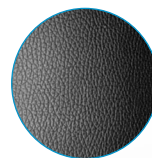

BLACK

ADI910-01-BLK

PNEUMATIC HEIGHT ADJUSTABLE EXAM STOOL

With Backrest

- Seat height can be quickly altered
- Ergonomically designed backrest
- Thick upholstery padding gives added comfort
- 5-star leg design provides stability when moving
- Smooth rolling wheels can handle carpeting and hard floors
- Overall Dimensions: 28"– 32.6" H x 22" W x 16.1 D
- Overall Weight: 16.5 lb

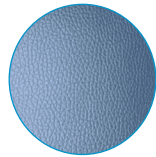

MIDNIGHT EXPRESS

ADI910-03-BLU

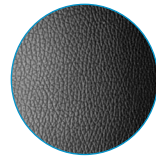

BLACK

ADI910-03-BLK



62

BLOOD DRAWING CHAIRS



PADDED BLOOD DRAWING CHAIR

- Overall Dimensions: 36" H X 30.5" W X 28" D
- Overall Weight: 35 lb
- Weight Capacity: 400 lb

- Padded for optimal patient comfort
- Armrest that can lock into the correct position
- Easy-to-clean antimicrobial polyurethane leather
- Welded powder-coated frame with reinforced stress points

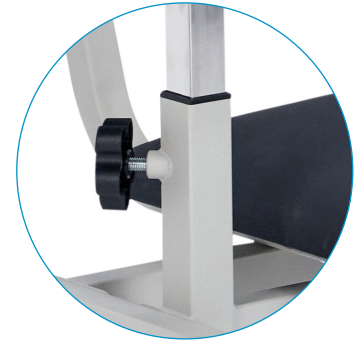

ARMREST HEIGHT ADJUSTMENT:
24.4" - 34.2"

BLACK
ADI997-01-BLK

MIDNIGHT EXP.
ADI997-01-BLU

500 LB CAPACITY

Optional Accessory

DRAWER

for Padded Blood Drawing Chair

BLACK # ADI997-01-BLK **MID. EXP.** # ADI997-01-BLU

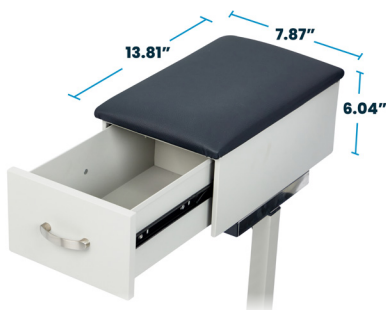

PADDED BLOOD DRAWING CHAIR

With Drawer

- Amply sized 4" x 6" drawer for various medical supplies

BLACK
ADI997-01D-BLK

MIDNIGHT EXPRESS
ADI997-01D-BLU

BARIATRIC PADDED BLOOD DRAWING CHAIR

- Overall Dimensions: 40" H X 35" W X 30" D
- Overall Weight: 48.5 lb

- Securely holds up to 500 lb
- Padded for optimal patient comfort
- Armrests that can lock into the correct position
- Easy-to-clean antimicrobial polyurethane leather
- Welded powder-coated frame with reinforced stress points



ARMREST HEIGHT ADJUSTMENT:
27.8" - 38.5"

- BLACK**
ADI997-01-BLK-HD
- MIDNIGHT EXP.**
ADI997-01-BLU-HD

500 LB CAPACITY

Optional Accessory

DRAWER

for Bariatric Padded Blood Drawing Chair

- BLACK**
ADI997-01-BLK
- MID. EXP.**
ADI997-01-BLU

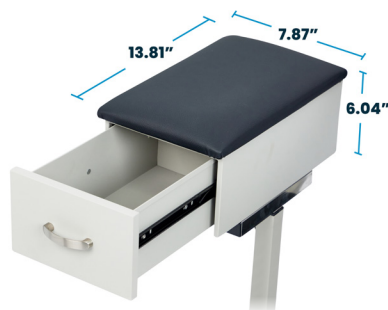

BARIATRIC PADDED BLOOD DRAWING CHAIR

With Drawer

- Amply sized 4" x 6" drawer for various medical supplies

- BLACK**
ADI997-01D-BLK-HD
- MIDNIGHT EXPRESS**
ADI997-01D-BLU-HD

LUXE UPHOLSTERED BLOOD DRAWING CHAIR

- Padded for optimal patient comfort
- Armrest that can lock into the correct position
- Easy-to-clean antimicrobial polyurethane leather
- Welded powder-coated frame with reinforced stress points
- Overall Dimensions: 35" H X 28" W X 25" D
- Overall Weight: 54 lb

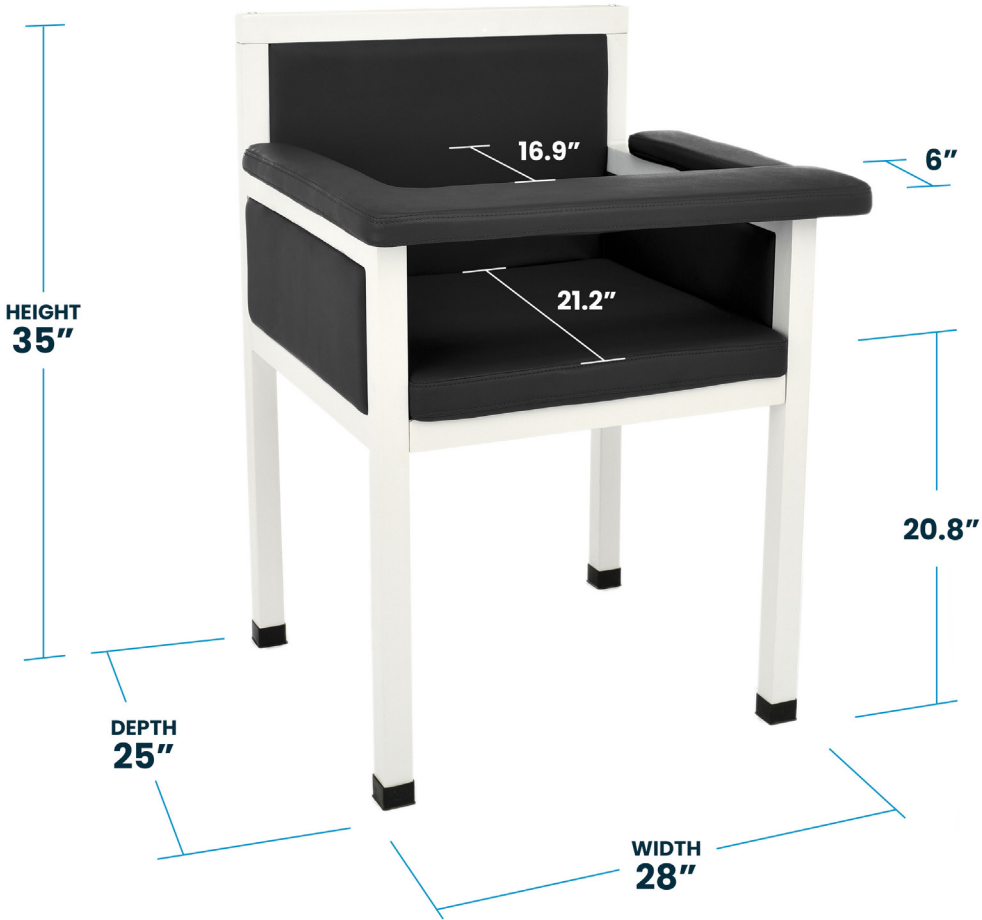

BLACK

ADI997-02-BLK



MIDNIGHT EXPRESS

ADI997-02-BLU



FOLDING PADDED BLOOD DRAWING CHAIR

ADI997-03-BLK

- Can be effortlessly transported
- Foldable design to facilitate storage
- Easy-to-clean antimicrobial upholstery
- Seat designed with a thick cushion for patient comfort
- Equipped with nylon glides on the legs to avoid scratching your floors
- Overall Dimensions: 37" H X 25.5" W X 24" D
- Overall Weight: 28 lb



EASILY FOLDABLE



HEIGHT MEASURING RODS

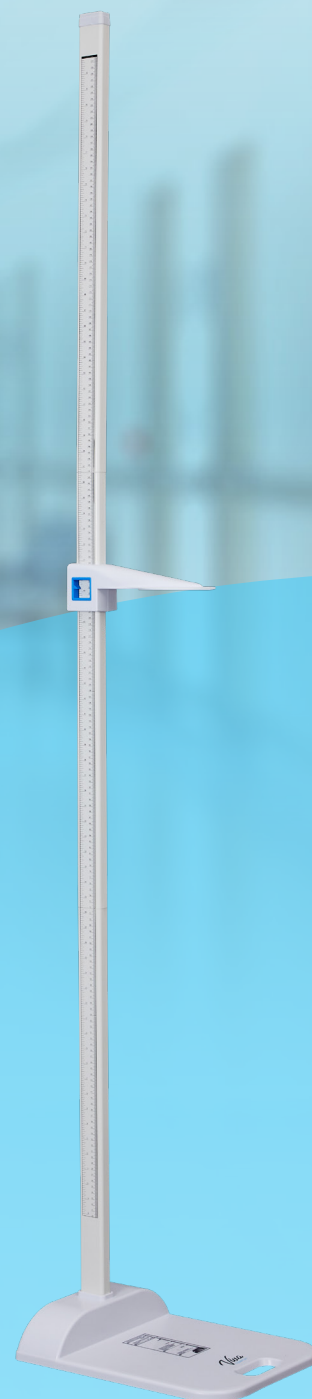

ADIME907-01

ALUMINUM PORTABLE HEIGHT MEASURING ROD

For Adults and Children,
and with Carrying Bag

- Sliding baffle for precise measurement
- Easy to transport, assemble and disassemble
- Dimensions: 82.68" x 12.6" x 16.54"
- Weight: 5.73 lb



INCLUDED CARRYING BAG

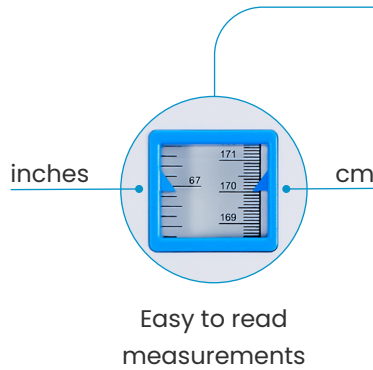

ADIME907-02

ALUMINUM WALL MOUNTED HEIGHT MEASURING ROD

For Adults and Children

- Offered in two wall mounting options
- Measuring range spans from 23.62" to 78.74"
- Dimensions: 36.81" H x 1.33" W x 2.08" D
- Weight: 1.65 lb



GLOVE DISPENSERS



ACRYLIC GLOVE DISPENSER

Single Box Capacity

- Crafted from high-quality acrylic
- Can be mounted vertically and horizontally
- Elevates your space with its modern appearance
- Universal design accommodates all glove brands
- Able to be mounted with supplied adhesive strips or screws
- Overall Dimensions: 5.3" H X 10.2" W X 3.5" D
- Overall Weight: 0.7 lb



Mounting Hardware Included



CLEAR

ADI902-01



BLACK

ADI902-01-BLK

ACRYLIC GLOVE DISPENSER

Double Box Capacity

- Crafted from high-quality acrylic
- Can be mounted vertically and horizontally
- Elevates your space with its modern appearance
- Universal design accommodates all glove brands
- Able to be mounted with supplied adhesive strips or screws
- Overall Dimensions: 10.8" H X 10.2" W X 3.5" D
- Overall Weight: 1.3 lb



Mounting Hardware Included



CLEAR
ADI902-02

BLACK
ADI902-02-BLK



ACRYLIC GLOVE DISPENSER

Triple Box Capacity

- Crafted from high-quality acrylic
- Can be mounted vertically and horizontally
- Elevates your space with its modern appearance
- Universal design accommodates all glove brands
- Able to be mounted with supplied adhesive strips or screws
- Overall Dimensions: 16" H X 10.2" W X 3.5" D
- Overall Weight: 1.8 lb



Mounting Hardware Included



CLEAR

ADI902-03

BLACK

ADI902-03-BLK



ACRYLIC GLOVE DISPENSER

Quad Box Capacity

- Crafted from high-quality acrylic
- Can be mounted vertically and horizontally
- Elevates your space with its modern appearance
- Universal design accommodates all glove brands
- Able to be mounted with supplied adhesive strips or screws
- Overall Dimensions: 21" H X 10.2" W X 3.5" D
- Overall Weight: 2.4 lb



Mounting Hardware Included



CLEAR
ADI902-04



BLACK
ADI902-04-BLK

SHARPS & NEEDLE DISPOSAL CONTAINERS



SHARPS AND NEEDLE DISPOSAL CONTAINER

1 Quart

- Dimensions Per Container: 6" H X 4.3" W X 4" D
- Weight Per Container: 0.19 lb

- Designed to be puncture resistant
- Made from robust, heat-resistant PP material
- Features a split-lid design and dual openings
- Temporary closure and snap locks provide ultimate protection
- Crafted with a transparent lid to see the filling progress

1-Pack

ADI998-01-01



3-Pack

ADI998-01-03



6-Pack

ADI998-01-06



SPLIT-LID DESIGN



SHARPS CONTAINER WITH MAILBOX-STYLE HORIZONTAL LID

5 Quarts

- Dimensions Per Container: 11" H X 10.6" W X 4.5" D
- Weight Per Container: 0.66 lb

- Designed to be puncture resistant
- Made from robust, heat-resistant PP material
- Mailbox-style lid allows the disposal of needles without direct contact
- Crafted with a transparent lid to see the filling progress
- Outfitted with locks to ensure safe transportation and sharps disposal



LID OPENING

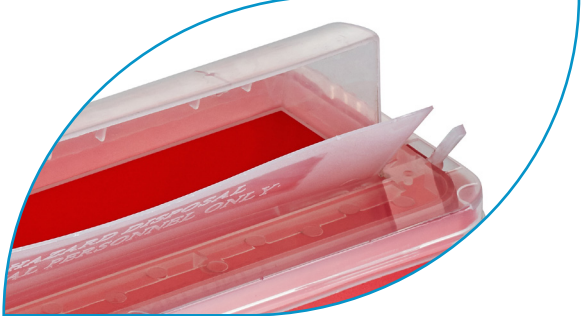

1-Pack

ADI998-02-01



2-Pack

ADI998-02-02



SHARPS CONTAINER WITH FLIP-OPEN LID

8 Quarts

- Dimensions Per Container: 9.8" H X 8.2" W X 7" D
- Weight Per Container: 0.73 lb

- Features a flip-open lid design
- Designed to be puncture resistant
- Made from robust, heat-resistant PP material
- Crafted with a transparent lid to see the filling progress
- Accommodates larger syringes and has a significant holding capacity

1-Pack

ADI998-03-01



2-Pack

ADI998-03-02



FLIP-OPEN LID DESIGN



SHARPS SHUTTLE CONTAINER

With Locking Mechanism

- Dimensions Per Container: 6.5" H X 1.2" D
- Total Weight: 0.26 lb

- Designed to be puncture resistant
- Made from robust, heat-resistant PP material
- Allows for one-handed operation
- Cap is specifically designed to be leak-resistant, providing secure containment
- Convenient size easily fits into bags for EMS, Fire and Rescue, and Nursing

6-Pack

ADI998-04-06



LEAK-RESISTANT CAP



SHARPS CONTAINER ROUND SHAPED

1.5 Quarts

- Dimensions Per Container: 6" H X 5.5" W X 4.3" D
- Weight Per Container: 0.25 lb

- Designed to be puncture resistant
- Made from robust, heat-resistant PP material
- Outfitted with protective plastic liner and tie
- Crafted with a transparent lid to see the filling progress
- Attached cover ensures contents stay safely inside the container

1-Pack

ADI998-05-01



2-Pack

ADI998-05-02



SAFETY



Outfitted cover ensures that the contents stay safely inside the container

80

PILL CRUSHER



PILL CRUSHER

- Overall Dimensions: 11.42" L x 4.33" W x 3.15" H
- Weight: 3.30 lb

- Designed to help streamline the medication administration process
- It can be used for a wide range of medications, making it a useful tool in any healthcare setting



ADIME950-01

PILL POUCH

For AdirMed Pill Crusher

- Clear plastic pouches help to ensure that the crushing process is hygienic, reducing the risk of contamination



- Overall Pouch dimensions: 3.94" x 1.97"
- Quantity: 1,000 pouches

ADIME950-02



EXAM ROOM PACKAGES





VIVA COMFORT EXAM ROOM PACKAGE

Ready with everything you need

Available items:

- **Exam Table**
Your choice of model and upholstery color
- **Exam Stool**
Your choice of model and upholstery color
- **Medical Scale**
Digital, beam, wheelchair or handrail scale
- **Wall Cabinet**
36-Inch or 48-Inch size
- **Base Cabinet**
36-Inch or 48-Inch size
- **Acrylic Gloves Dispenser**
Your choice of capacity
- **Soap & Hand Sanitizer Dispenser**
ALP425-WHI, ALP423-SSB or ALP424-SSB
- **Multifold Paper Towel Dispenser**
ALP480, ALP481, ALP481-S or ALP454-ECO-TBLK
- **Stainless Steel Trash Can**
ALP470-65, ALP470-65L, ALP470-10L, ALP470-20L, ALP470-40L, ALP470-R-40L

84 CUSTOMIZE AN EXAM ROOM PACKAGE THAT BEST FITS YOUR NEEDS WITH THE BELOW PRODUCTS:

Choose your **EXAM TABLE**



Grande Steel Exam Table



Noble-Line Exam Table

Choose your **EXAM STOOL**



Luxe Exam Stool



Pneumatic Height Adjustable Exam Stool

Choose your **MEDICAL SCALE**



Digital



Beam



Wheelchair



Handrail

Choose your **WALL CABINET**



36-Inch Wall Cabinet



48-Inch Wall Cabinet

Choose your **BASE CABINET**



36-Inch Base Cabinet



48-Inch Base Cabinet

- Left Sink
- Right Sink
- No Sink

Choose your **GLOVE DISPENSER**



Single Box



Double Box

Choose your **SOAP DISPENSER**



White



Stainless Steel Vertical



Stainless Steel Horizontal

Choose your **STEEL TRASH CAN**



17 Gallon



34 Gallon

Choose your **PAPER TOWEL DISPENSER**



C-Fold / Multi-Fold



C-Fold / Multi-Fold



C-Fold / Multi-Fold



Roll Paper



2.7 Gallon



5.2 Gallon



10.5 Gallon



10.5 Gallon

Dual Compartment

CONTACT INFORMATION

 Monday - Thursday: 9:00am - 5:30pm EST / Friday: 9:00am - 3:00pm EST

 800.292.6277

 cs@vivacomfort.com



Scan Our QR Code To
Check Out Our Website

© 2024 Viva Comfort. All Rights Reserved.

Manufacturer reserves its right to change technical specification and configuration of the equipment in the course of its further development.

