

.....

POWER HI-LO 2-SECTION TILT TABLE

.....

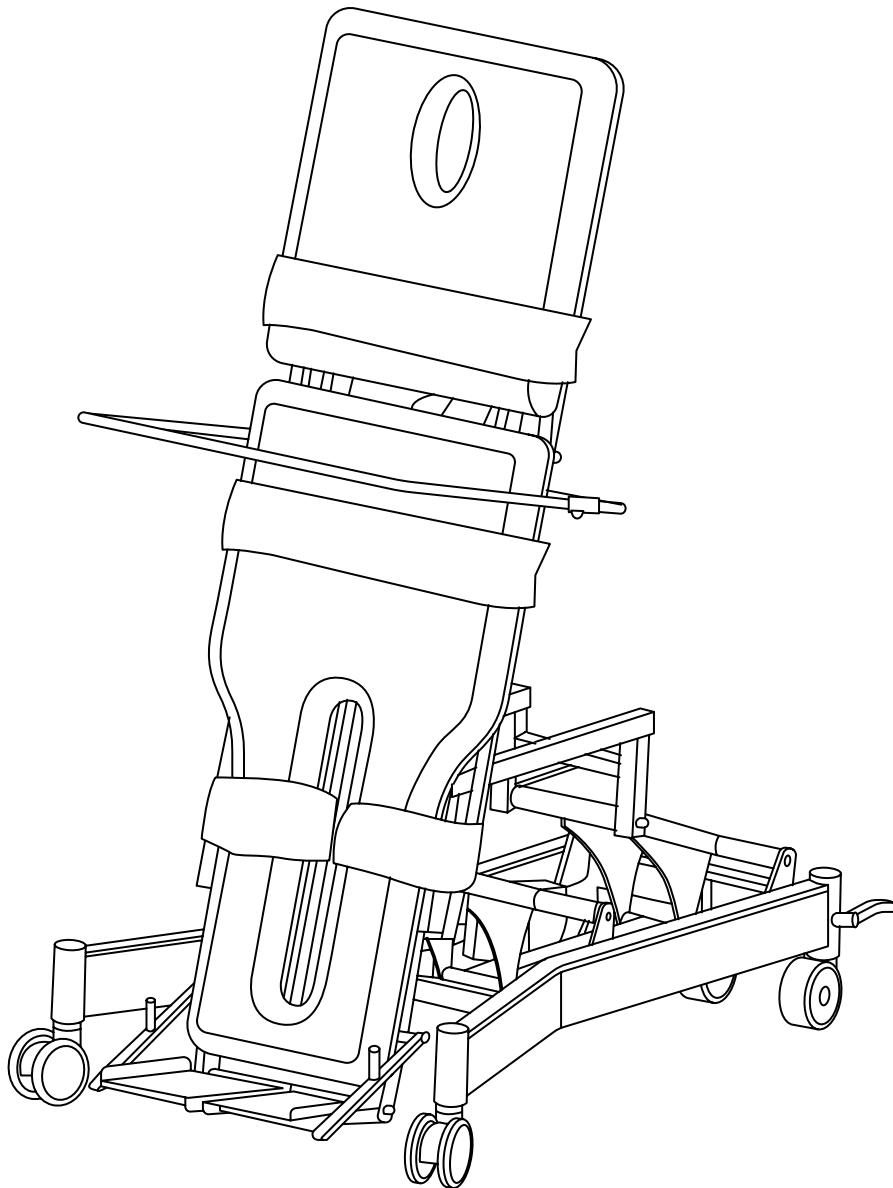

USER GUIDE

ADI903-05



Thank you for your purchase.

Viva Comfort maintains a strong practice of ongoing development of products and commercial research.

We recognize that starting and maintaining a medical practice is expensive. We'll help make the process cost-effective and elegant. Additionally, our team of specialists will ensure everything you need works as efficiently as possible, so you can effectively treat your clients.

Table of Contents

4	Warning: Important Safety Instruction
4	Safety Precautions
4	Normal Operating Conditions
5	Regulation and Product Standards
6	Precautions and Safety Indications
7	Technical Specifications
7	Placement in the Workplace
8	Operating Instructions
11	Legend to Symbols and Information on the Product Label
12	Troubleshooting
12	Maintenance
12	Recycling
13	Care & Maintenance Guide
17	Transportation and Storage Condition
17	Shutdown Procedure
18	Warranty
19	Notes

WARNING: IMPORTANT SAFETY INSTRUCTION:

Before operating this exam table, **LIFT THE FOOTBOARD UPWARD.**

Failure to do so will cause the wheels to lift off the ground, risking potential injury or equipment damage.

Safety Precautions

1. During the adjustment of the table, do not put any part of the body into the gap of any moving parts.
2. Please operate with both hands when adjusting the leaning angle of the back, foot, or head sections.
3. When the patient is on the table, it is not recommended to adjust the angle of the table top.
4. Before using the product, ensure that the four wheels of the table frame touch the ground at the same time and check its stability.
5. Before connecting to the power supply, please check whether the incoming line to the controller is intact.
6. A regular inspection (at least once a year) is needed for the treatment table.
7. Do not exceed the table weight capacity of 485 lb. The safe working load of the armrest is 33.07 lbs. (15 kg).
8. Always clean the table after each use with a soft cloth dampened with water and a mild antibacterial detergent. Do not use abrasive cleaners. Please reference the "**Cleaning and Disinfection**" section for more detailed cleaning instructions.
9. Disconnect the table from the power source before attempting any maintenance, installation, removal, or replacement procedures to prevent electrical shock and possible damage to the table.
10. Please **DO NOT** make any changes to the table. Viva Comfort, or the selling dealer, can provide replacement parts.

Normal Operating Conditions

Temperature: 0°C - 40°C

Relative humidity: 10% - 95%

Air pressure range: 860-1060hpa

Power supply: AC 100-240V, 50/60Hz

Regulation and Product Standards

This table complies with the European regulation of medical devices (EU) 2017/745 and with the following standards:

- **EN 60601-1:2006+A1:2013+AC:2014**

Medical electrical equipment. Part 1: General Requirements for Basic Safety and Essential Performance.

- **IEC/EN 60601-2-52:2009+A1:2015 clause 201.9.8.3.2**

Medical electrical equipment. Part 2-52: Particular requirements for basic safety and essential operation of medical tables.

- **EN 60601-1-6:2010+A1:2015**

Medical electrical equipment. Part 1-6: General Requirements for basic safety and essential performance. Collateral standard: Suitability for use

- **EN 60601-1-2:2015**

Medical electrical equipment. Part 1-2: General requirements for basic safety and essential performance. Collateral standard:

Electromagnetic disturbances. Requirements and tests.

- **EN ISO 13485:2016**

Medical devices - Quality management systems - Requirements for regulatory purposes
(ISO 13485:2016)

- **DIN EN ISO 13485:2016**

Precautions and Safety Indications

Viva Comfort is not liable for any material or personal damage caused by misuse or incorrect use of this table or for any purpose other than that described in this user guide.

- Inspect the condition of the table before using it for the first time and regularly, as indicated in the “**Maintenance**” section.
- Keep table out of high moisture environments.
- Refrain from transporting the table over rough or outdoor surfaces. The retractable caster system could become damaged and inoperable.
- This table should be operated, transported, and stored at temperatures between -10° C and + 50° C, with a max humidity of 95 %.
- **DO NOT** operate this table in an environment where other devices are being used that intentionally radiate electromagnetic energy in an unshielded manner. Portable and mobile communications equipment can affect Medical Electrical Equipment.

This table generates, uses, and can radiate radio frequency energy and, if not installed and used per the instructions, may cause harmful interference to other nearby devices. However, there is no guarantee that interference will not occur in a particular installation. Harmful interference to other devices can be determined by turning this table on and off. Try to correct the interference using one or more of the following:

- Reorient or relocate the receiving device.
- Increase the separation between the equipment.
- Connect the table to an outlet on a different circuit from the one on which the other device(s) are connected.
- Consult Viva Comfort or your local dealer for help.
- Unplug the table from the power supply before cleaning or performing maintenance operations.
- The table should be kept out of the reach of children when there is no adult supervision.
- The table is designed for discontinuous interval operation, so the continuous running time of the motor should never exceed 2 minutes. Should this happen, damage may occur due to overheating of the electronics.
- Always use original accessories and spare parts provided by your local dealer.
- Always cover the table with a towel, disposable paper, or a cover and change it for each user. This ensures correct hygiene and extends the useful life of the upholstery.
- Connect the table only to a properly installed and grounded outlet. The local mains voltage must correspond to the device’s technical data.
- The power outlet should be accessible if the table needs to be quickly unplugged at any given time.
- Always pull the plug and not the main cable.
- Unplug the table from the power supply before cleaning or performing any type of maintenance operation.

Technical Specifications

Product Dimensions:

Power Hi-Lo 2-Section Tilt Table

Length: 76.38" (1940mm)

Width: 25.20" (640mm)

Lifting range of bed surface: 22.44"- 40.94" (570-1040mm)

Height (bed surface at the highest): 40.94" (1040mm)

Tilting angle: -2° to 85°

Size of activity table: 11.81"x28.74" (300x730mm)

If the electrical supply cable is defective, disconnect the table immediately and inform your dealer or a specialized technician.

Position the power cord properly so that it cannot be tripped over.

Unplug the power cord from the mains if the table is not going to be used for a long period of time.

If you detect any abnormality in the operation of the table, consult your dealer or a specialized technician.

Never manipulate any electrical part or open or repair any part of the table.

Only your dealer or a specialized technician should repair the table.

Never touch the table or the power cord with wet hands.

Never place your hands or any other part of your body in any hole or void on the table while it is in operation.

Make sure there are no objects in the space under the table that could cause collisions or entrapment during operation.

Make sure that your feet are not resting on the peripheral foot bar or foot control during treatment and especially when sitting near the table. This could create a dangerous situation where your leg is caught between the section and the peripheral foot bar or floor surface.

Take into account the weight distribution on the table when working. The weight must be distributed along the table without concentrating on its ends to maintain the correct stability.

You should not sit on the head and foot sections. If you do, there is a danger of tipping and table damage.

Placement in the Workplace

The table has four casters to facilitate movement to the place where it will be used.

Once correctly positioned, the table has two adjustable legs that prevent it from moving during use.

Operating Instructions

Table in a Working Position:

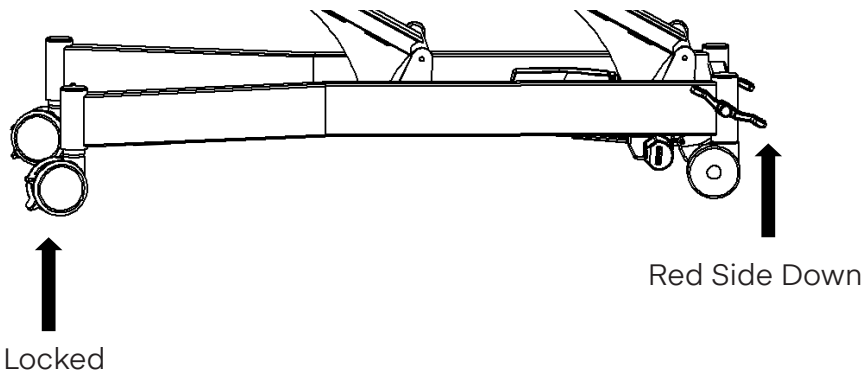
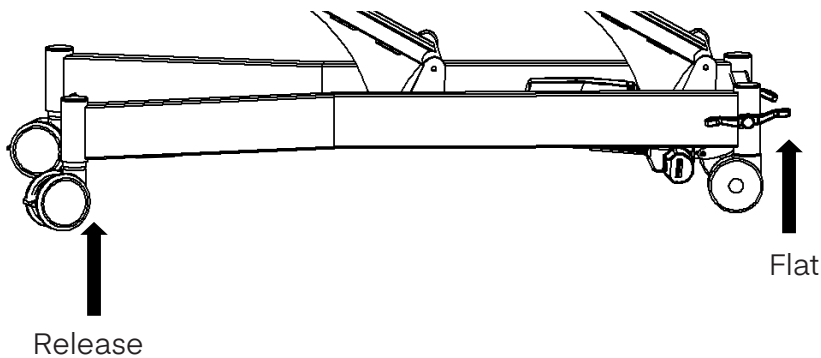

Table in a Moving Position:



Connect the table to an electrical outlet using the power cord.

Motor Functions:

- Hand controller is used for adjusting height & tilt.
- Before adjusting, make sure there are no objects in the space below the table that could cause collisions or entrapment.
- Press LINE 1 on the controller panel ▲▼ to adjust the height of the table.

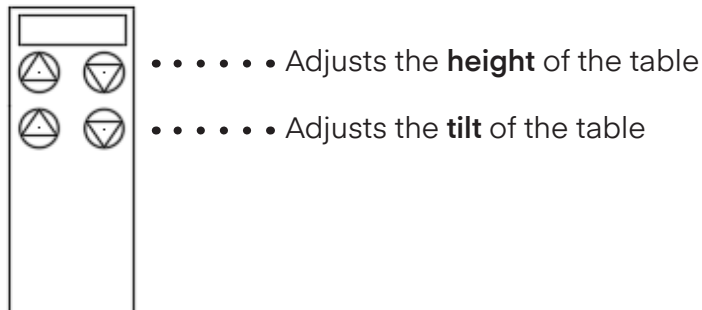

- Press LINE 2 on the controller panel ▲▼ to adjust the tilt of the table.

Fixing and Adjusting the Activity Table:

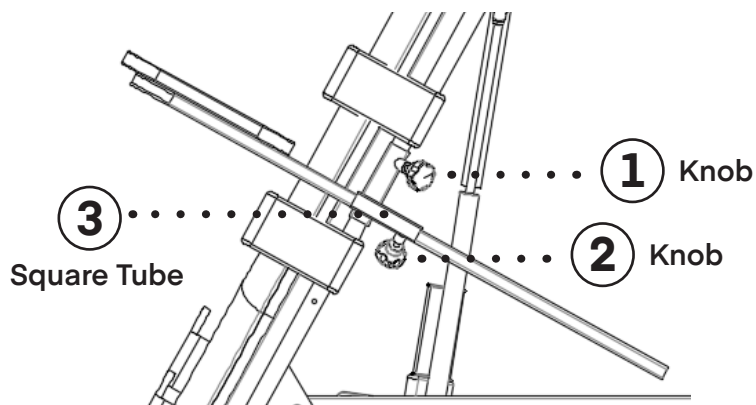

When installing the activity table, do not relax your hands before the activity table is fixed to avoid accidental slippage and cause injury.

Step 1:

A. Insert the square rod of activity table into the square tube (3), adjusting the square rod to the right distance then tighten the knob (2) to fix.

Step 2:

A. To adjust the height of the activity table tighten the knob (1) on the bracket to fix it in place.

Adjusting the Foot Board Plate:

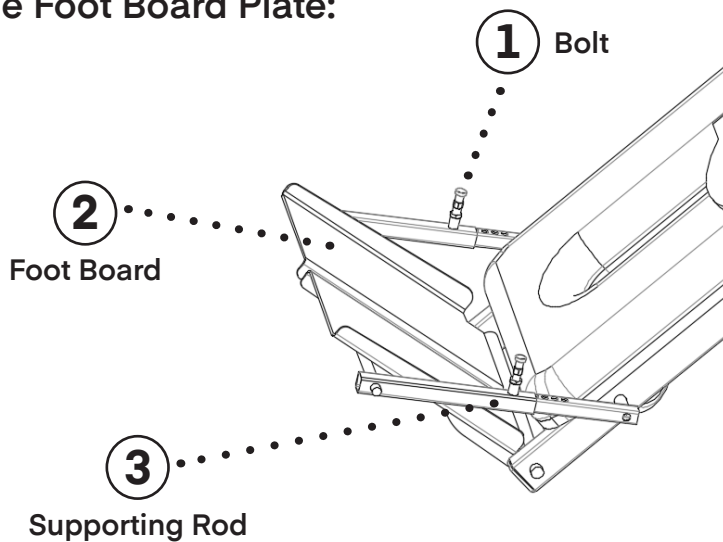

Before adjusting make sure the table is in the non-tilting position.

Step 1:

A. Release the bolt (2) then adjusting the supporting rod (3).

Step 2:





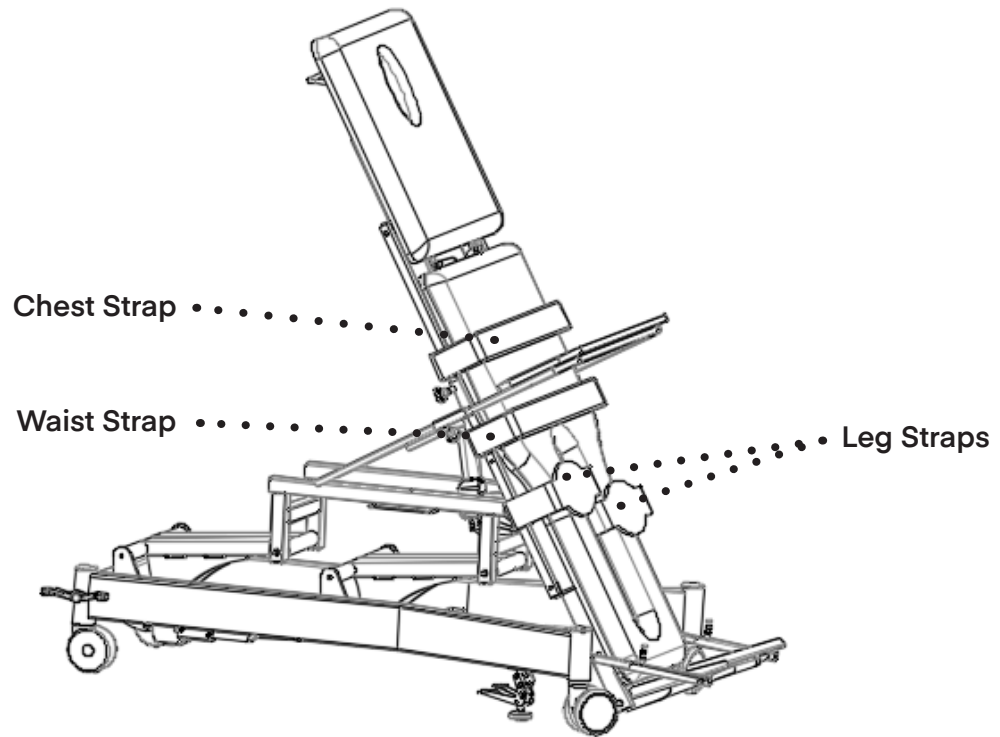





A. The foot board can be adjusted to suit the desired angle Increment depends on the patient's need.

Fixation Straps:

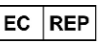

- Tighten the belts by fastening the straps.
- The position of the straps can be moved up and down along the square tube.

Legend to Symbols and Information on the Product Label

- **Model** : Product identification.
- **Model Num.** : Product version.
-  : CE conformity marking.
-  : Unique serial number identifying the product.
-  : Date of manufacture.
- **Product Net Weight** : Table weight in kg.
- **INPUT** : Necessary values of the electrical mains supply.
- **ON: 2 min / OFF: 18 min** : Indicates the discontinuous operation of the device according to IEC/EN 0601-1, which indicates that 2 minutes of continuous operation of the motor or motors should not be exceeded.
-  : Consult the instructions for use or the user guide.
- **Max Load** : Maximal load capacity that the table can support.
-  : Waste from Electrical and Electronic Equipment. Selective waste collection of electrical and electronic equipment is required.
-  : Classification of medical electrical equipment - Double Insulation.
-  : Electrical Safety Classification - Type B.
- **IPX4** : Protection against splashing water or liquids.
-  : Manufacturer identification.
-  : Authorized representative in the EU.
-  : Importer.

Troubleshooting

During the life of the table you detect any malfunction or need a repair, contact your dealer and do not use the table until you have received a diagnosis or the table has been professionally repaired.

Maintenance

Carry out a visual inspection at least once a month to check the general conditions of the table. Moreover, you must do the following:

- Check the correct adjustment of the different sections.
- Check the proper functioning of the motors and their movements.
- Check and clean the gas struts.
- Check and tighten screws (if necessary).
- Grease the parts with friction.
- Check the conditions of the electrical wiring and the socket.
- Check the wheel immobilization system.

Recycling

If you need to dispose of the table or any of its parts or accessories, consult and respect the laws and regulations applicable to waste management and protection of the environment.

Care & Maintenance Guide

Disclaimer: Viva Comfort will not be held responsible for any damage to the upholstery or surfaces of our products due to cleaning attempts made, whether correctly or improperly conducted. We will not be liable for any damage to the upholstery or the product surfaces, such as discoloration or deterioration, from attempting to clean.

Thank you for purchasing a Viva Comfort product. We are honored to have your business and serve your medical equipment needs. To ensure your product(s) stay in optimal condition, even with consistent use, we have crafted a Care & Maintenance Guide to help you properly maintain and sanitize your product. Please carefully read these guidelines and follow the recommendations listed. Please contact our customer service representatives if you have any questions regarding these instructions.

Note: Before cleaning the table, unplug it from the mains.

Note: Clean the table after each use.

Note: Be mindful when using sharp or pointed objects in the vicinity of upholstery and exam tables. They can cause damage to the exam table surfaces and puncture or tear the upholstery.

Note: DO NOT use pumice stones, scouring pads, steel wool, or textured cleaning pads to clean any surface of the exam table or the upholstery. We recommend a microfiber towel or a soft cloth.

Note: DO NOT store steel wool on/in your exam tables or on your upholstery.

Upholstery Cleaning:

Viva Comfort uses premium antimicrobial upholstery on all our exam tables. Consistent care should be taken to maintain the upholstery's integrity. We recommend that you always test the solutions below on an inconspicuous spot before using them on the entire upholstery. The below solutions still require you, the user, to follow proper and safe handling of the products. Carefully review all warnings on the labels of any cleaning agents you utilize and ensure it's compatible with our upholstery.

The following Cleaners, Cleaning Materials, and Chemical Makeups will deteriorate and cause permanent damage to your upholstery.

Please Note: Should anything spill on your upholstery, wipe it up immediately and rinse it several times with water to avoid damage.



- Avoid using acidic or abrasive cleaners, as they can cause damage to your upholstery.
- Avoid using dyes (hair, textile, food) near your exam tables as they will permanently stain your upholstery. Should a dye spill occur, wipe it up as soon as possible with dishwashing detergent or an all-purpose cleaner. This is not guaranteed to solve the problem, it but can help reduce the chance of staining.
- Avoid using drainer cleaners or rust removers near your upholstery. Should drain cleaner spill, wipe it up as soon as possible, and rinse it several times with water. Should rust remover spill, wipe off all residue immediately, wash the area with dishwashing soap, and rinse it several times. Ensure you thoroughly dry the area.

- Avoid using the following products near or on your exam tables, as they will cause damage to the surface that may result in discoloration and/or deterioration.

CHEMICAL COMPOUND	AFFILIATED NAMES
Silicon Dioxide	Pumice/Pumice Stones, Degreaser
Sodium Hydroxide	Caustic Soda, Caustic, Lye, Soda Lye, Degreaser, Drainer Cleaner
Hydrofluoric Acid	Rust Remover, Toilet Bowl Cleaner, Concrete Cleaner, Metal Polishes
Phosphoric Acid	Tile Cleaner, Toilet Bowl Cleaner, Rust Remover, Concrete Cleaner
Sulfuric Acid	Oleic Acid, Oil of Vitriol, Oleum, Drain Cleaner, Heavy-Duty Acidic Cleaner
Hydrochloric Acid	Muriatic Acid, Hydrogen Chloride, Toilet Bowl Cleaner, Calcium, Lime and Rust Remover

Below are the recommended cleaning instructions for our antimicrobial upholstery.

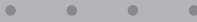
Please Note: DO NOT use any alcohol-based cleaning agents, as this will degrade the upholstery.

MILD SOIL LEVEL 	<p>If the surface is lightly soiled, we recommend using a solution comprised of mild dish soap (10%) mixed in warm water (90%). Saturate a soft towel and clean the upholstery gently. In a separate bucket, have clean water and a soft towel. Thoroughly rinse the upholstery with clean water, as well as dry it completely.</p>
MODERATE SOIL LEVEL 	<p>If the surface is moderately soiled, we recommend using a solution comprised of Fantastik® (50%) and warm water (50%). Saturate a soft towel and clean the upholstery gently. In a separate bucket, have clean water and a soft towel. Thoroughly rinse the upholstery with clean water, as well as dry it thoroughly.</p>
SEVERE SOIL LEVEL 	<p>If the surface is severely soiled, we recommend using a solution comprising of bleach (10%) and warm water (90%). Saturate a soft, white towel and clean the upholstery gently. In a separate bucket, have clean water and a soft, white towel. Thoroughly rinse the upholstery with clean water, as well as dry it completely. Since this solution utilizes bleach, please only use it when necessary; ensure all the bleach solution is removed from the bed, do not let the solution sit on the upholstery, and understand that discoloration may occur.</p>

- Fantastik® is a registered trademark of DowBrands, Inc.®, Registered trademark of the Dow Chemical Co.®

Exam Bed Surface Cleaning:

The following Cleaners, Cleaning Materials, and Chemical Makeups will deteriorate and cause permanent damage to your exam beds' surfaces.

Please Note: Should anything spill on your exam table's surface, wipe it up immediately and rinse it several times with water to avoid damage.



- Avoid using acidic or abrasive cleaners, as they can cause damage to your exam table and its upholstery.
- Avoid using dyes (hair, textile, food) near your exam tables as they will permanently stain your table. Should a dye spill occur, wipe it up as soon as possible with dishwashing detergent or an all-purpose cleaner. This is not guaranteed to solve the problem, it but can help reduce the chance of staining.
- Avoid using drainer cleaners or rust removers near your exam table. Should drain cleaner spill, wipe it up as soon as possible, and rinse it several times with water. Should rust remover spill, wipe off all residue immediately, wash the area with dishwashing soap, and rinse it several times. Ensure you thoroughly dry the area.
- Avoid using the following products near or on your exam tables, as they will cause damage to the surface that may result in discoloration and/or deterioration.

CHEMICAL COMPOUND	AFFILIATED NAMES
Silicon Dioxide	Pumice/Pumice Stones, Degreaser
Sodium Hydroxide	Caustic Soda, Caustic, Lye, Soda Lye, Degreaser, Drainer Cleaner
Hydrofluoric Acid	Rust Remover, Toilet Bowl Cleaner, Concrete Cleaner, Metal Polishes
Phosphoric Acid	Tile Cleaner, Toilet Bowl Cleaner, Rust Remover, Concrete Cleaner
Sulfuric Acid	Oleic Acid, Oil of Vitriol, Oleum, Drain Cleaner, Heavy-Duty Acidic Cleaner
Hydrochloric Acid	Muriatic Acid, Hydrogen Chloride, Toilet Bowl Cleaner, Calcium, Lime and Rust Remover

Compatible Household Cleaners For Exam Bed Surfaces

Below is a list of compatible cleaners to use on the exam bed surfaces. We recommend that you always test the solutions below on an inconspicuous spot before using them on the entire surface. The below solutions still require you, the user, to follow proper and safe handling of the products. Carefully review all warnings on the labels of any cleaning agents you utilize and ensure it's compatible with our exam bed surfaces. We will not be liable for any damage to your product surfaces, such as discoloration or deterioration, from attempting to clean.

(These cleaner recommendations are only for exam bed surfaces; DO NOT use the below cleaners on the upholstery. For instructions on how to clean your upholstery, refer to our "Upholstery Cleaning" section.)



Dawn®

Fantastik®

Windex®

Clorox®

Lysol®

Formula 409®

Glass Plus®

Lestoil®

Laminate Surface Cleaning:

Note: Though the tips below are recommended for cleaning soiled and stained areas, we will not be liable for any damage to the product surfaces, such as discoloration or deterioration, from attempting to clean.

Note: The below solutions still require you, the user, to follow proper and safe handling of the products. Carefully review all warnings on the labels of any cleaning agents you utilize and ensure it's compatible with our product.

Note: Be sure to utilize proper protective equipment before handling the below cleaning solutions.

MILD SOIL LEVEL • • • •	If the surface is lightly soiled, we recommend using a soft cloth or microfiber towel dampened with a mild soap and water mixture to clean the area.
MODERATE SOIL LEVEL • • • • • • • • • • • • • • •	If the surface is moderately soiled, we recommend using a solution comprised of a mild household cleaner and baking soda. Create a paste consistency with the recommended cleaning agents, take a nylon bristle brush, and lightly scrub the affected area. DO NOT use a metal bristle brush nor aggressively scrub, or you will cause permanent damage to the surface. Thoroughly rinse the area with clean water, as well as dry it thoroughly.
SEVERE SOIL LEVEL •	If the surface is severely soiled, we recommend using undiluted bleach. Use a cotton pad/ball with bleach on it to gently rub the affected area for a minute or so. Thoroughly rinse the area with clean water, as well as dry it completely. Since this solution utilizes bleach, please only use it when necessary; ensure all the bleach solution is removed from the area, do not let the solution sit on the surface, and understand that discoloration may occur.

-
- Fantastik® is a registered trademark of Dow Brands, Inc.®, Registered trademark of the Dow Chemical Co.®
 - Dawn® is a registered trademark of The Procter & Gamble Company®.
 - Windex® is a registered trademark of S.C. Johnson & Son, Inc.®.
 - Clorox® is a registered trademark of The Clorox Company®.
 - Lysol® is a registered trademark of Reckitt Benckiser LLC®.
 - Formula 409® is a registered trademark of The Clorox Company®.
 - Glass Plus® is a registered trademark of Reckitt Benckiser LLC®.
 - Lestoil® is a registered trademark of The Clorox Company®.

Transportation and Storage Condition

Transport Condition

The products can be transported by general means of transportation. They should be protected from the sun and rain, and should not be mixed with toxic, harmful and corrosive materials.

Storage

The packed electric multifunctional physiotherapy bed should be stored in a dry and well ventilated environment without corrosive gas.

Shutdown Procedure

Transport Condition

Adjust the bed to a suitable position to ensure that the patient is safe, then turn off the power.

Contraindication

Please note that our beds are not sterilized.

Please do not use them according to aseptic standards.

Warranty

1. Viva Comfort (the "Company" or "Tiger Companies") warrants to the purchaser that the product will be free from defects in workmanship and materials for a period of 3 years from the date of purchase. The warranty period is not extended if we repair, replace, exchange, or provide a refund for the product (as determined in our sole discretion). We may change the availability of this limited warranty at our discretion, but any changes will not be retroactive.
2. These warranties are not assignable or transferable to any other person, including, without limitation, any subsequent owner or other transferee of the product.
3. This Warranty does not apply to: (a) damage caused by misuse, tampering, abuse, neglect, or accident; (b) damage caused by improper installation, modification, or service; (c) alteration of the serial number; or (d) use that violates the instructions furnished by the Company will void this warranty.
4. The sole responsibility of the Company shall be limited to (a) the repair or replacement (in its sole discretion) of any component of the product which fails to conform to this; (b) a refund the purchase price of such product (in its sole discretion), at no cost to the purchaser for the period of the warranty, or (c) an exchange for a similar product, comparable in function and price.
5. Contact the Company directly at 1-(800)-805-1790 to obtain service under this warranty. If it becomes applicable to send a defective product to the Company, a Return Authorization Number must first be obtained from the Company. In order to obtain service under this warranty, purchaser may be required to provide the Company with the following items (a) proof of purchase, (b) photographs and or videos (of the damage, and (c) a written testimonial describing the defect.
6. Products shipped without prior Return Authorization and Return Authorization Number may not be accepted, and the Company will not be responsible for their disposition and/or cost of return to the owner.
7. The Company will not assume any responsibility for any loss or damage incurred in shipping and or delivery.
8. The product(s) must be returned within 14 calendar days of receiving the return authorization from the Company and must include the original proof of purchase for the warranty to be honored.
9. Any implied warranties that the purchaser may have are limited to the duration of the warranties described above. There are no further warranties that extend or apply beyond the face hereof, and the Company expressly disclaims and excludes any and all warranties of merchantability or fitness for a particular purpose. Some states do not allow limitations on how long an implied warranty lasts, so the above limitation may not apply to you.
10. THE REMEDIES DESCRIBED ABOVE ARE YOUR SOLE AND EXCLUSIVE REMEDIES AND THE COMPANY'S ENTIRE LIABILITY FOR ANY BREACH OF THIS LIMITED WARRANTY. OUR LIABILITY SHALL UNDER NO CIRCUMSTANCES EXCEED THE ACTUAL AMOUNT PAID BY YOU FOR THE DEFECTIVE PRODUCT, NOR SHALL WE UNDER ANY CIRCUMSTANCES BE LIABLE FOR ANY CONSEQUENTIAL, INCIDENTAL, SPECIAL OR PUNITIVE DAMAGES OR LOSSES, WHETHER DIRECT OR INDIRECT. SOME STATES DO NOT ALLOW THE EXCLUSION OR LIMITATIONS OF INCIDENTAL OR CONSEQUENTIAL DAMAGES, SO THE LIMITATION MAY NOT APPLY TO YOU.
11. This warranty gives you specific legal rights, and you may also have additional rights which vary from state to state.

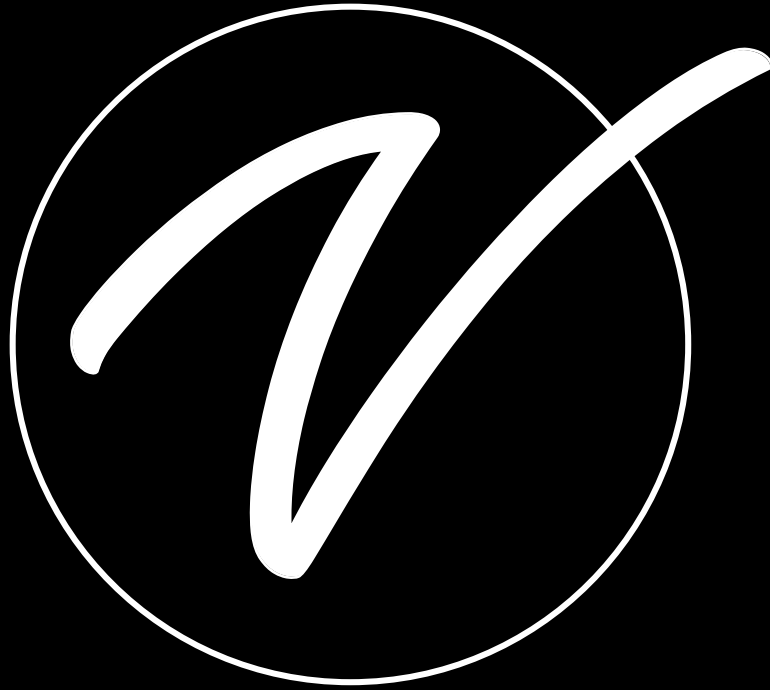

ADIME903-05

© 2024 Viva Comfort

vivacomfort.com